

CASE STUDIES OF REHABILITATION OF EXISTING REINFORCED
CONCRETE BUILDINGS IN MEXICO CITY

by

JORGE ALFREDO AGUILAR, B.S.C.E.

THESIS

Presented to the Faculty of the Graduate School
of The University of Texas at Austin
in Partial Fulfillment
of the Requirements
for the Degree of

Master of Science in Engineering

The University of Texas at Austin

December, 1995

CASE STUDIES OF REHABILITATION OF EXISTING REINFORCED
CONCRETE BUILDINGS IN MEXICO CITY

APPROVED BY

SUPERVISING COMMITTEE:

James O. Jirsa

Michael E. Kreger

To Ana

An invaluable partner in this and all projects

ACKNOWLEDGMENTS

Previous work on this subject was reported by Sergio Brena[1990]. In his study five case studies were presented which used as basis for this project and expanded with the addition of seven case studies and the information in the initial five projects was updated to reflect the experience of the past five years. Most of the information and the photographic material of the case studies were made available by the Area of Structures of the “Universidad Autonoma Metropolitana”(Mexico).

My deepest thanks go to Dr. James O. Jirsa for his encouragement and support. You have my sincere appreciation for this opportunity, it was an honor to work with you.

Special thanks to Professor Jesus Iglesias for his help and comments on this thesis. Thanks are also due to Dr. Michael E. Kreger for acting as a second reader. Thanks to Mr. Oscar de la Torre for the information he made available to complete the case studies.

The financial support that I received from the “Consejo Nacional de Ciencia y Tecnologia” (Mexico) and the “Universidad Autonoma Metropolitana” was essential for the realization of this project.

Jorge A. Aguilar

Austin, Texas, November 1995

ABSTRACT

CASE STUDIES OF REHABILITATION OF EXISTING REINFORCED CONCRETE

BUILDINGS IN MEXICO CITY

by

JORGE ALFREDO AGUILAR, M.S.E.

The University of Texas at Austin, 1995

SUPERVISOR: JAMES O. JIRSA

The objective of this study is to document the repair and strengthening techniques for reinforced concrete structures that were used following the 1985 Mexico earthquake and to discuss the diverse issues that influenced rehabilitation projects.

Typical construction practices in Mexico City are described. The main characteristics of the 1985 earthquake and its effects on the different types of structures are presented. Twelve rehabilitation case studies representing the main techniques and building systems are included. The most important issues considered in the redesign and problems on techniques related to the construction procedure are presented.

TABLE OF CONTENTS

	PAGE
Chapter 1: INTRODUCTION	1
Chapter 2: THE 1985 MEXICO CITY EARTHQUAKE	3
2.1 The 1985 Mexico City Earthquake:	
Ground motion characteristics	3
2.2 Building Types in Mexico City	5
2.2.1 Foundation Types	5
Footings and Mats	6
Compensated Foundations	7
Partially Compensated Foundations	7
Friction Pile Foundations	8
Point Bearing Pile Foundations	8
Control Pile Foundations	9
2.2.2 Superstructure	10
Unreinforced Masonry Bearing Walls	10
Reinforced masonry Bearing Walls	11
Moment-Resisting Concrete or	
Steel Frames	12
Waffle Slab Systems	12
Beam-Block Floor Systems	13
Dual Systems	14
2.3 Building Damage in the 1985 Earthquake	14
2.3.1 Damage Statistics	14
2.3.2 Foundation Damage	17
Mat Foundations	17
Friction Piles Foundations	17
Point Bearing Piles	18
Control Pile Foundations	18
2.3.3 Structural Damage in Concrete Structures	18
Beam Damage	18
Column Damage	19
Slab Damage	19
Beam-Column Joint Damage	19
Concrete Wall Damage	20
Chapter 3: MEXICO CITY CODES AND REQUIREMENTS	21
3.1 Codes	21
1942 Code	21
1957 Emergency Norms	21
1966 Code	23
1976 Code	24

PAGE

1985 Emergency Norms	26
1987 Code	26
3.2 Post-Earthquake Stabilization Requirements	28
3.3 Evaluation Procedures	28
3.4 Inspection and Supervision of Project	31
 Chapter 4: GENERAL REHABILITATION TECHNIQUES	 33
4.1 Materials Used In Repair.....	33
4.1.1 Resins	34
4.1.2 Concrete	34
Cast in Place	34
Shotcrete	35
Resin Concrete	36
4.1.3 Mortars and Grouts	36
4.1.4 Steel Elements	37
4.2 Local Strengthening of Elements	37
4.2.1 Injection	37
4.2.2 Material Substitution	38
4.3 Rehabilitation Techniques	40
4.3.1 Modification of Existing Elements	40
Concrete Jacketing	40
Columns	40
Beams	42
Steel jacketing	44
Columns	44
Beams and Slabs	45
Increase in Wall and Slab Sections	46
Post-tensioning	47
4.3.2 Change of Lateral Force	48
Resisting System	48
Concrete Structural Walls	49
Steel Bracing	51
Cable Bracing	53
Concrete Frames	53
Infill Walls	53
4.3.3 Special Techniques	54
Floor Removal	55
Foundation Strengthening	55
4.4 Verification of the Performance of Rehabilitated Structures.....	56
 Chapter 5: CASE STUDIES.....	 57
5.1 Building A	57
	PAGE

5.2 Building B	70
5.3 Building C	84
5.4 Building D	93
5.4 Building E	101
5.6 Building F	114
5.7 Building G	127
5.8 Building H	135
5.9 Building I	142
5.10 Building J	149
5.11 Building K	155
5.12 Building L	162
Chapter 6: CONCLUSIONS	173
BIBLIOGRAPHY	175
VITA	178

CHAPTER 1

INTRODUCTION

Greater Mexico City with a population of about twenty million people is one of the world's largest metropolitan areas. The fast increase in population in the last few decades was accompanied by large housing construction projects and a highly concentrated urban environment. The urban area has about 800,000 buildings that includes both modern structural systems and old traditional structures. It is situated in the Valley of Mexico which is underlain by a complex soil formation that has been a continuing challenge for structural engineers.

On September 19, 1995, a major earthquake occurred along the Pacific coast of Mexico and produced extensive destruction. In Mexico City, over 10,000 deaths were recorded. The local site conditions led to high amplification of the ground motion and about 400 buildings were severely damaged or collapsed. The estimated total direct damage was 4 billion dollars. The magnitude of that damage made Mexico City an enormous natural laboratory in which many modern structural systems were subjected to large lateral forces and cyclic displacements.

After the 1985 earthquake, rehabilitation of damaged structures and strengthening of undamaged structures had to meet updated and increased requirements imposed by the Mexico City Building Code. As a result, many different strengthening and repair techniques were developed and implemented.

The widespread damage to modern construction in Mexico City after the 1985 earthquake had not been seen in any city before. The event firmly demonstrated the lack of general information on repair and strengthening design procedures and construction practices. Experimental data on performance of rehabilitated systems was needed. However, damaged structures had to be repaired as soon as possible after the earthquake to respond to the demands of the inhabitants of the buildings in question and to reduce the hazard in future seismic events. To meet this challenge engineers came up with inventive solutions even though there was not enough experimental data available and little design guidance that could be utilized.

Analysis and documentation of the effects of large earthquakes on engineered buildings and the recording of solutions implemented to minimize losses in future events are important tools for increasing our knowledge about the performance of buildings in large concentrated urban areas of high seismic risk. The main objective of this report is to present a survey of the most common retrofitting techniques that have been used in Mexico City after the 1985 earthquake. The data gathered from repaired buildings will serve as a foundation for future investigations on the behavior of retrofitted structures and on the effectiveness of the methods used. It should be noted that there were buildings damaged in 1985 that had been repaired following earthquakes in 1957 and 1979, however it was not possible to learn much from that because no record of the repairs were available.

Some general aspects of the characteristics of the ground motion experienced in 1985 are presented in Chapter 2. The unique subsoil characteristics in Mexico City are briefly described and an overview of the most common structural types and foundations is also given. Statistics and descriptions of damage to various building types are presented. In Chapter 3, the evolution of the Mexico City Code and post-earthquake evaluation procedures are reviewed.

The most common rehabilitation techniques adopted in Mexico City are described in Chapter 4. The methods range from local strengthening and/or upgrading of existing elements to changes of the lateral force resisting system in structures. The advantages and limitations of each procedure are discussed. Twelve rehabilitation projects involving reinforced concrete buildings are presented in Chapter 5. The effectiveness of the repairing techniques used has yet to be proved and only the occurrence of future earthquakes or data from ongoing research will determine the adequacy of those techniques. In Chapter 6, some concluding remarks are presented.

CHAPTER 2

THE 1985 MEXICO CITY EARTHQUAKE

2.1 THE 1985 MEXICO CITY EARTHQUAKE: GROUND MOTION CHARACTERISTICS

The earthquake that struck Mexico City in 1985 consisted of two separate events, one occurring 26 sec. after the other and making the determination of focal coordinates quite difficult [Rosenblueth, et al. 1986]. The epicenter of the earthquake was located roughly 400 km. southwest of Mexico City. The focal depth was approximately 18 km. The earthquake was generated in the subduction zone between the Cocos Plate and the North American Plate located along the Pacific Coast. The magnitude of the surface waves generated by the compound event was fixed at $M_s = 8.1$. What was unique about this event is the amount of heavy damage that occurred at such a large distance from the source. This phenomena has triggered numerous investigations on the effects of attenuation and local conditions on the characteristics of ground motion [Seed, et al. 1987].

The soil in Mexico City has a very particular stratigraphy which had a significant effect on the distribution of the damage. The subsoil of the Valley of Mexico can be divided into three zones: lake bed, transition, and hill zone. The lake bed zone contains deep deposits of lacustrine clay deposits with high compressibility and interbedded with firm strata at different depths. The natural water content of the soft clay deposits can range from 100% to 500%, whereas the natural water content of the first firm stratum, often termed first hard layer and formed by silty clays and silty sands, is about 50%. The first hard layer is found from 30 to 35 m. deep and has been used to support buildings on point bearing foundations [Marsal 1987] (see section 2.2.1). Below the first hard layer there is another layer of highly compressible clays with a thickness between 9 and 15 m. At depths greater than 55 m. heavily consolidated sands form what is known as the deep hard layer. This stratigraphy is typical of the area where the old lake was located, mainly at the center and southeastern part of the city. Towards the eastern part of Mexico City, the first hard layer disappears, and the deep hard layer has been found at depths of approximately 70 m. (Airport area).

The transition zone is characterized by a 10 m. thick layer of lacustrine clay deposits bound on top and bottom by semi-compacted sandy layers. The transition zone is bounded by the lake bed on one side and by the hill zone on the other.

The soils in the hill zone are composed of volcanic tuffs which have high strength and are largely incompressible.

Most of the buildings damaged during the 1985 earthquake were located in lake bed zone, and some damage, although not extensive, was found in the transition zone. A comparison between accelerograms recorded on the hill zone (UNAM) and on the lake bed zone (SCT) shows the importance of the site effects on the ground motion for

this earthquake. The peak ground acceleration registered at UNAM, corresponding to the WE component of motion, was 34 gals and at SCT was 168 gals in the same direction [Mena 1985]. It is evident that the dynamic properties of the soil at the lake bed zone had great influence on the amplification of seismic waves. The highly compressible clays that constitute the upper layers of the soils in the lake bed zone show almost a linear elastic behavior under dynamic excitations due to their high water content, and have very low damping properties (less than 5%) for strains as high as 0.15% [Seed, et al. 1987]. Shear wave velocities as low as $V_s = 40$ m/sec. have been recorded in these soils, and their natural period has been estimated at 2.0 sec. [Whitman 1987].

Another important characteristic of the 1985 earthquake was the almost harmonic motion registered in the lake zone and high energy content at a period around 2.0 sec. The intense phase of the accelerogram record for the WE component of motion in the SCT site is shown in Figure 2.1 and the acceleration response spectra for 0 and 5% damping is shown in Figure 2.2.

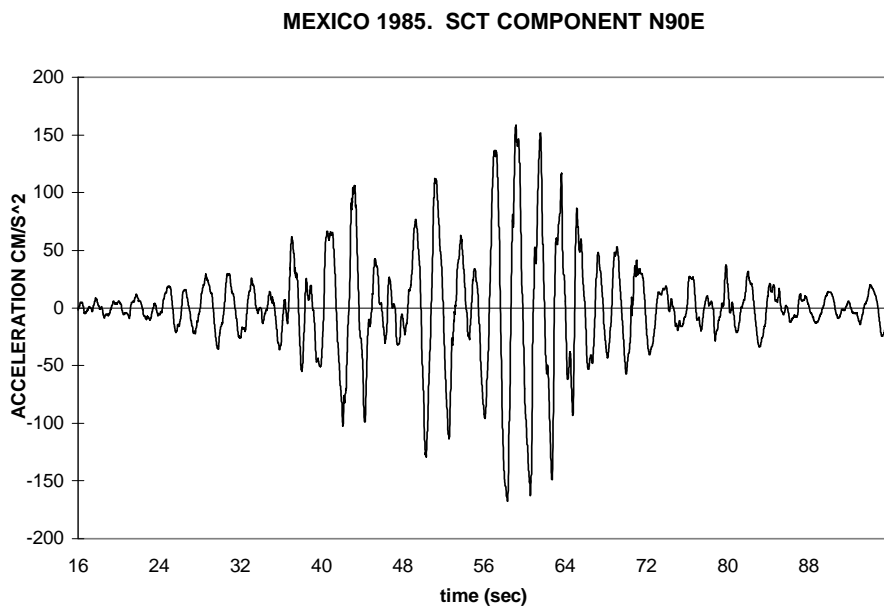

Figure 2.1 Ground acceleration recorded at SCT in Mexico City.

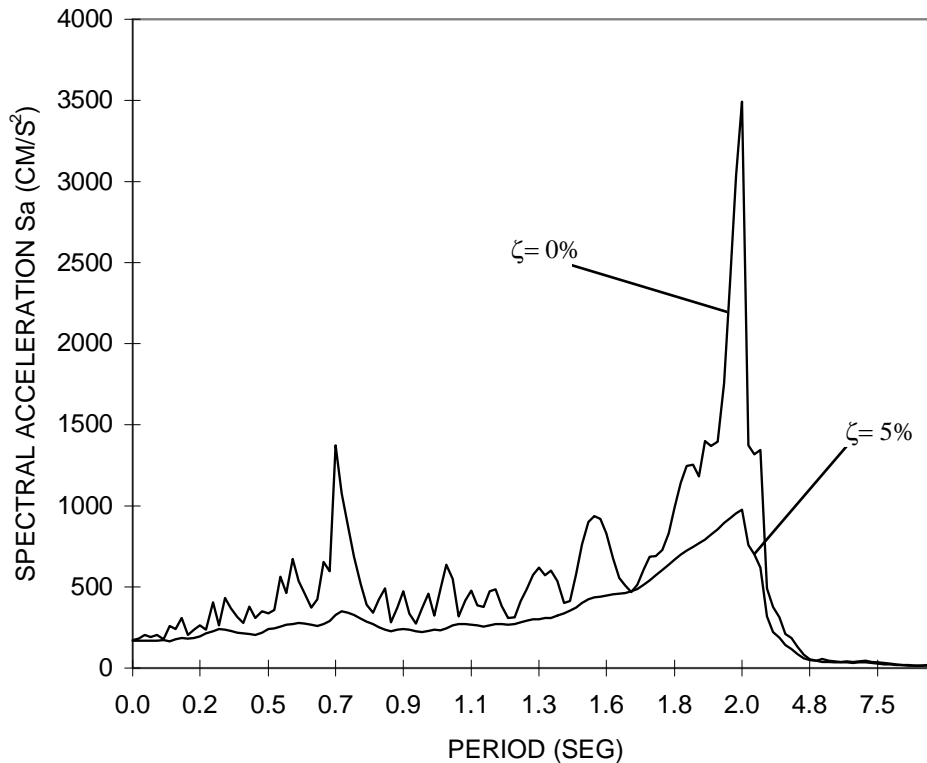

Figure 2.2 Acceleration response spectra for WE component.

It can be seen that the predominant response occurs at a period of about 2.0 sec. and explains why buildings having fundamental periods in this range were the most affected by the earthquake. Buildings located in the lake zone that had an initial natural period slightly below 2.0 sec. suffered the greatest damage because as yielding and damage occurred during the strong motion, the period became longer and closer to the predominant 2.0 sec. period. Even small period changes resulted in significantly higher structural response (Fig. 2.2).

Furthermore, the duration of strong motion between about 40 and 70 seconds (Fig. 2.1) and the harmonic characteristics of the ground motion created significant ductility demands on buildings and increased both the extent and level of damage.

2.2 BUILDING TYPES IN MEXICO CITY

2.2.1 Foundation Types

The design of foundations in Mexico City is controlled primarily by three factors which have to do with the particular subsoil in the valley: (1) the unique properties of the lacustrine clay deposits, (2) regional subsidence induced by pumping of water from the underground aquifer within the boundaries of the city, and (3) the high seismic

hazard of the zone. These three problems have required the development of special types of foundation structures described below.

Footings and Mats

Shallow foundations are used for low rise buildings (2 to 3 stories). Isolated footings are used in locations where soils have low compressibility and where the effects of differential settlements between columns may be minimized by superstructure flexibility. Continuous footings are used to control differential settlements between supported columns and in soils of medium to low compressibility. Differential settlements are controlled by means of foundation beams that are used to stiffen the footing. Beams may run in one or two perpendicular directions depending on the magnitude of the loads that are to be transmitted (Fig. 2.3).

When the loads are so large that continuous footings will cover close to 50% of the projected area of the building, a continuous mat covering the entire area is more likely to be used [Zeevaert 1983]. Mats can be used effectively where large total settlements may occur in soils of medium to high compressibility. The slab thickness is a function of the magnitude of the allowable total and differential settlements. Where the loads are so large that a reasonable slab thickness cannot be obtained, grade beams can be used to stiffen the foundation to control differential settlements (Fig. 2.4).

Compensated Foundations

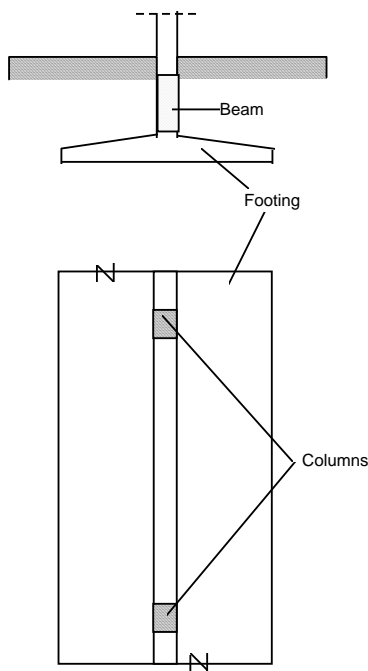

Figure 2.3 Continuous footing.

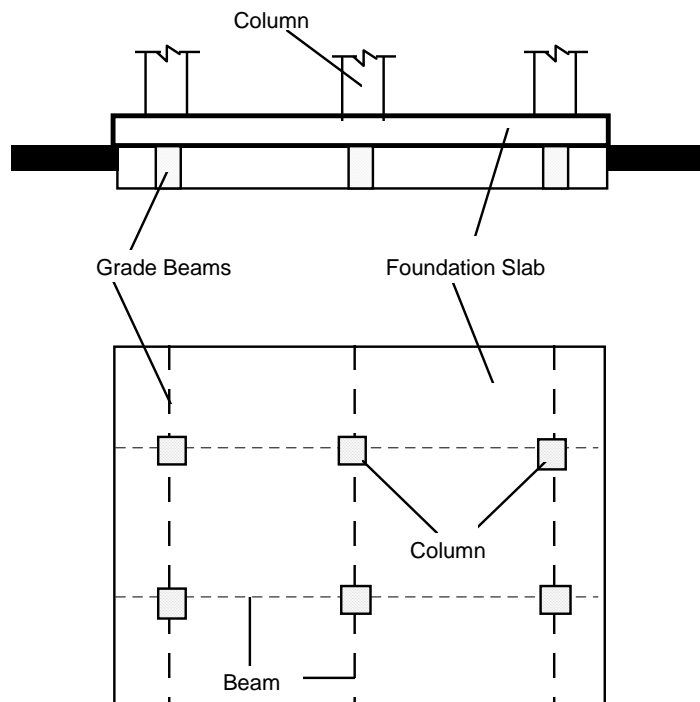

Figure 2.4 Mat foundation

Compensated foundations are used in locations where the soil has medium, high, or very high compressibility and low bearing capacity. The principle behind compensated foundations is to remove a volume of soil with a weight equivalent to that of the building. Therefore, a reinforced concrete mat and retaining walls are built to create an empty volume beneath the surface.

In order for this system to perform adequately, special care has to be taken during the excavation and construction phases to control the unloading and reloading of the soil mass to eliminate any possible soil expansion after unloading. The resulting foundation concrete box provides a stiff base in which differential settlements can be easily controlled. The base can be designed as a flat slab or as a slab-beam system with beams joining the columns (Fig. 2.5).

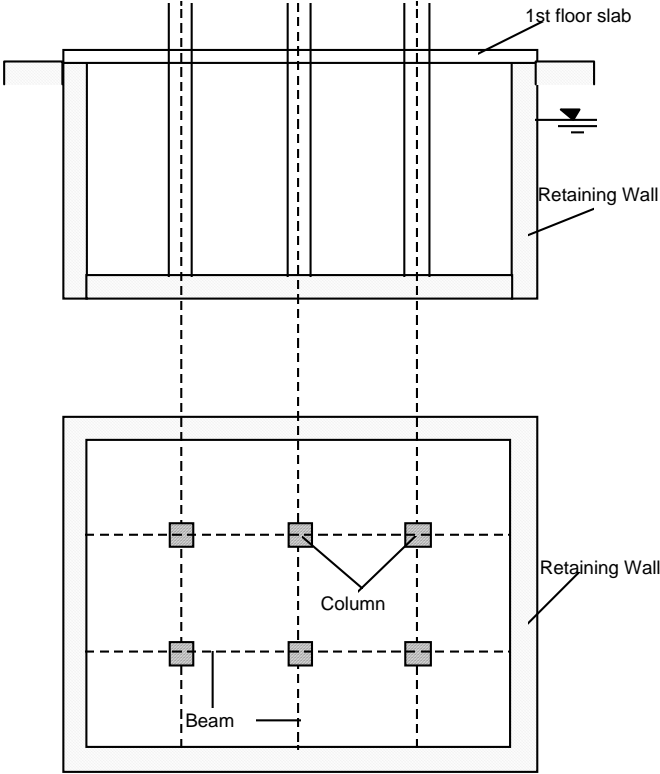

Figure 2.5 Compensated foundation.

Partially Compensated Foundations

In partially compensated foundations, not all of the building weight is compensated by soil substitution. A partially compensated foundation is common where the loads coming from the superstructure are too large to be offset by soil substitution without the use of deep excavations which may cause other difficulties. Partially compensated foundations consist of a combination of a box foundation and piles.

Friction Pile Foundations

These foundations are used in combination with partially compensated foundations. Part of the building weight is resisted by soil substitution and the rest carried by the piles (Fig. 2.6). As the building settles, skin friction is developed on piles and the rest of settlement is reduced.

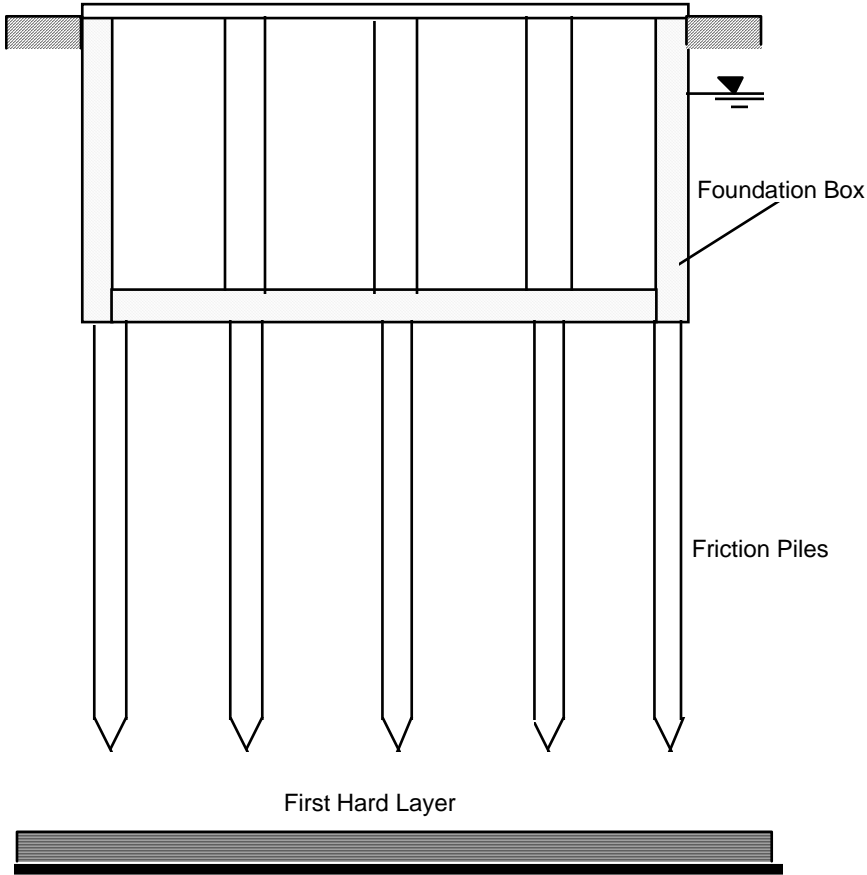

Figure 2.6 Partially-compensated foundation with friction piles.

Point Bearing Pile Foundations

In point bearing pile foundations, piles are driven to a depth where the stratum has low compressibility and high shear strength. The piles are generally driven to the first hard layer, located at a depth of approximately 30 to 35 m. (Fig. 2.7). In the foundation design, consideration must be given to effect any relative movement of the compressible soil with respect to the piles. Ground subsidence will generate negative skin friction on the piles and decrease the effective pile capacity.

In most cases, friction or end bearing piles are used in groups to transmit the structural load to the soil. A pile cap is constructed at the base of columns over the group of piles driven to support those columns.

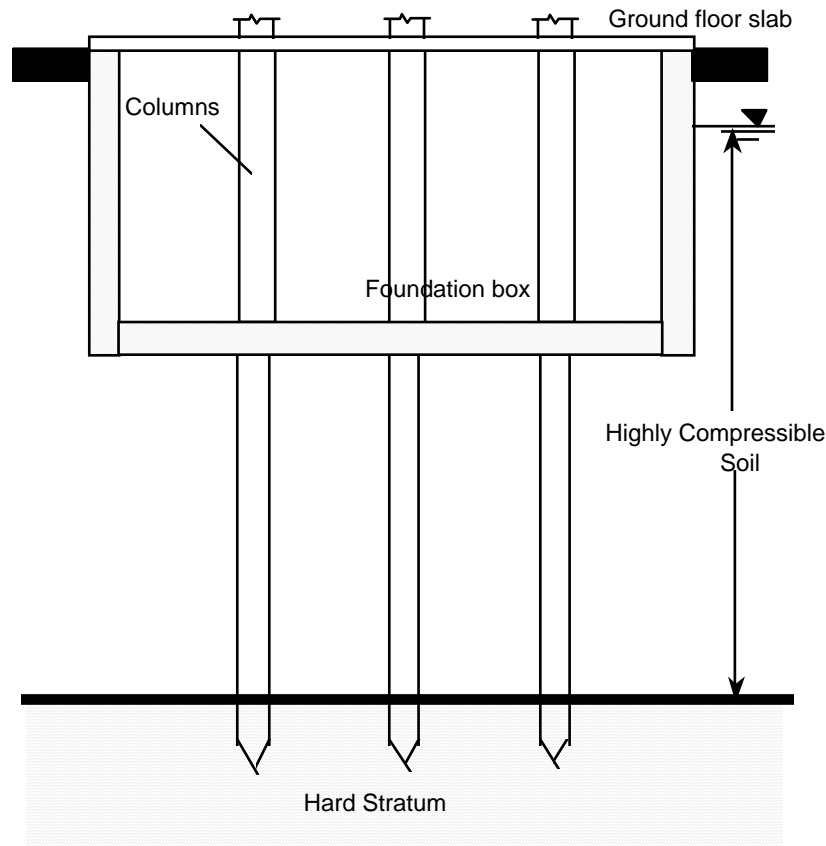

Figure 2.7 Point bearing pile foundation.

Control Pile Foundations

This special type of friction pile was developed as a solution for excessive settlements due to consolidation of the soft clay deposits as well as the emersion of buildings on end bearing piles. Piles penetrate freely through the foundation mat or pile cap. The force that is transmitted to each pile can be controlled by means of a control device between the head of the pile and the foundation mat or pile cap. The control device makes use of deformable cells, usually blocks of special high strength wood with elastoplastic compression response, which are placed between the pile cap and a steel beam connected to the mat or pile cap. Load transmitted to the pile caps is controlled by deformation of the wood blocks. The steel beam is connected to the pile cap or mat with threaded steel rods and nuts that can be adjusted to accommodate (or permit) differential settlements (see Fig. 2.8).

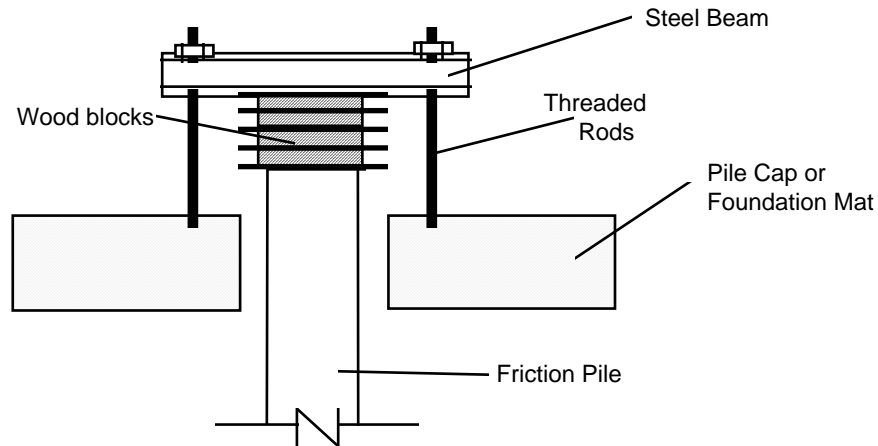

Figure 2.8 Control pile device.

2.2.2 Superstructure

Although much of the urban area of Mexico City has been developed in the last 50 years, there is a large and diverse inventory of buildings that includes structures over four centuries old and modern high rise buildings (up to 52 stories). The most common structural types in Mexico City can be classified into one of the following six generic groups [Fundacion 1988]:

Unreinforced Masonry Bearing Walls

This group includes structures with thick stone, brick or adobe bearing walls. The floor system in these structures consists of wood or steel beams that support heavy timber, arched brick, or arched natural stone floors or roofs (Fig. 2.9). Old construction with wall thickness of up to 50 cm. and very large interstory heights are included. These structures are usually highly deteriorated due to the lack of maintenance and the floor system is often in poor condition (rotten timber boards and beams). Also, cracking due to differential settlements is often encountered in the walls. These buildings can be up to four stories high.

A serious problem is the lack of a rigid diaphragm to transfer the lateral loads to the resisting elements which may result in an unsatisfactory distribution of lateral shear force. However, these buildings are quite stiff and the natural period of vibration is often less than 0.5 seconds making them less susceptible to the dynamic excitations characteristic of soft soil deposits in Mexico City.

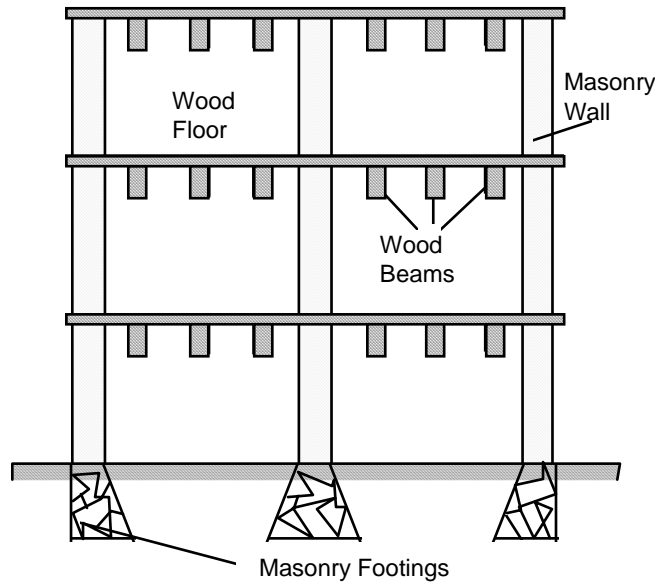

Figure 2.9 Masonry bearing walls with wood floor system.

Reinforced Masonry Bearing Walls

Reinforced masonry bearing wall structures consist of brick load bearing walls, but with thickness up to 28 cm. The floor system is usually a cast in place or precast reinforced concrete slab supported directly on the bearing walls and on reinforced concrete perimeter stiffening elements that confine the brick masonry walls (Fig. 2.10).

This structure is a modern version of unreinforced masonry buildings. “Confined

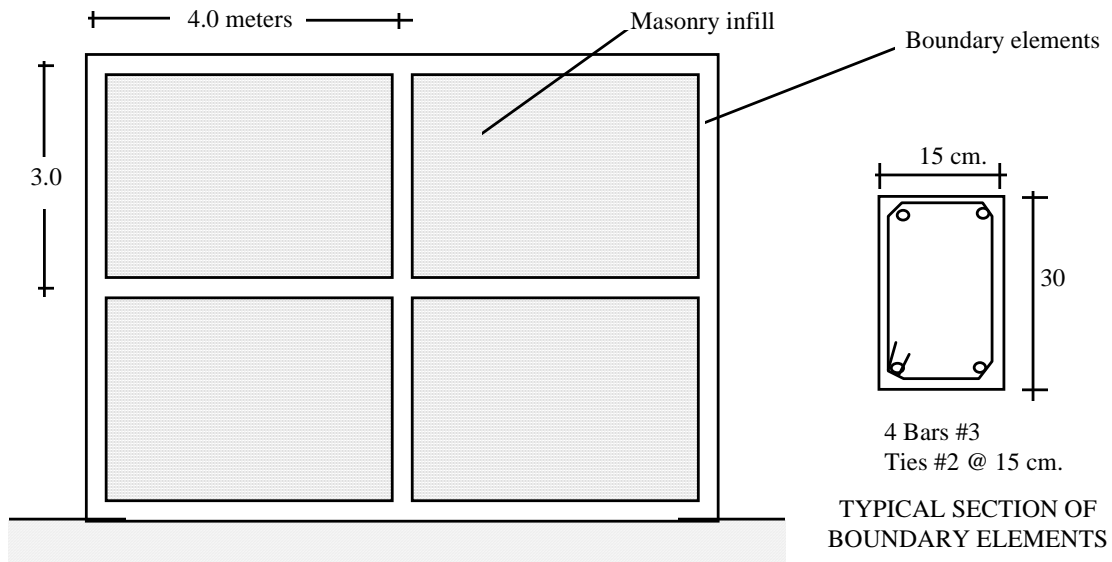

Figure 2.10 Typical arrangement of “confined masonry walls”.

masonry walls” are a form of masonry infill frame in which the infill is first made up of unreinforced solid clay bricks. A reinforced concrete frame, with the same wall thickness, is then cast against the masonry confining the masonry walls so that better behavior under lateral excitations as well as reduced differential settlements are attained. The reinforced concrete floor system forms a rigid diaphragm that distributes the lateral forces to the walls in both directions. Reinforced masonry systems are used in buildings up to eight stories tall. They are used primarily as apartment buildings and houses. The masonry wall density is relatively high, so that the lateral stiffness is large. Reinforced masonry wall structures did not suffer severe damage during the 1985 earthquake.

Moment-Resisting Concrete or Steel Frames

These structures consist of reinforced concrete or steel frames with beams and columns as part of the lateral and vertical resisting system. The floor system is a reinforced concrete two-way slab supported directly on the frame beams or on interior beams. Typical slab thicknesses range from 10 to 15 cm., and the slabs are usually cast in place. Usually, frame buildings have a high density of partition masonry. Partitions are considered to be non-structural in building design.

Buildings having up to forty floors have been built using this type of structure. The lateral forces are entirely resisted by the beams and columns that constitute the building frames. Therefore, the stiffness of these elements determines the dynamic response. The distance between columns depends on the use of the building, with greater spans for parking buildings than for office buildings (spans can be as long as 10 to 12 m.). However, the beam depth has often been limited due to architectural considerations, and as a consequence, beam stiffness has been drastically reduced, making the frames very flexible under lateral excitations. The fundamental period of buildings with 10 to 15 stories is close to 2 seconds. Buildings in this height range suffered severe damage in the 1985 earthquake.

Waffle Slab Systems

Waffle slab systems are structures consisting of reinforced concrete columns supporting a waffle slab with overall thickness ranging from 25 to 45 cm. typically. The slab has a rigid (solid) zone shown in Fig. 2.11 at the slab-column connection to improve the shear and moment transfer from the waffle slab to the column. "Equivalent" frames are formed by the columns and the floor system ribs. In the design, partition masonry walls are also considered to be non-structural. It is a typical construction practice in Mexico City to use sand-cement blocks to form the ribs in a waffle slab floor system. The blocks are left in place during casting of the floor concrete and become an integral part of the system. However, these offer almost no resistance to vertical or lateral loads, and are never considered as part of the load carrying system. Also, it has been common to use styrofoam blocks or removable forms instead of sand-cement blocks to reduce the slab weight (Fig. 2.11).

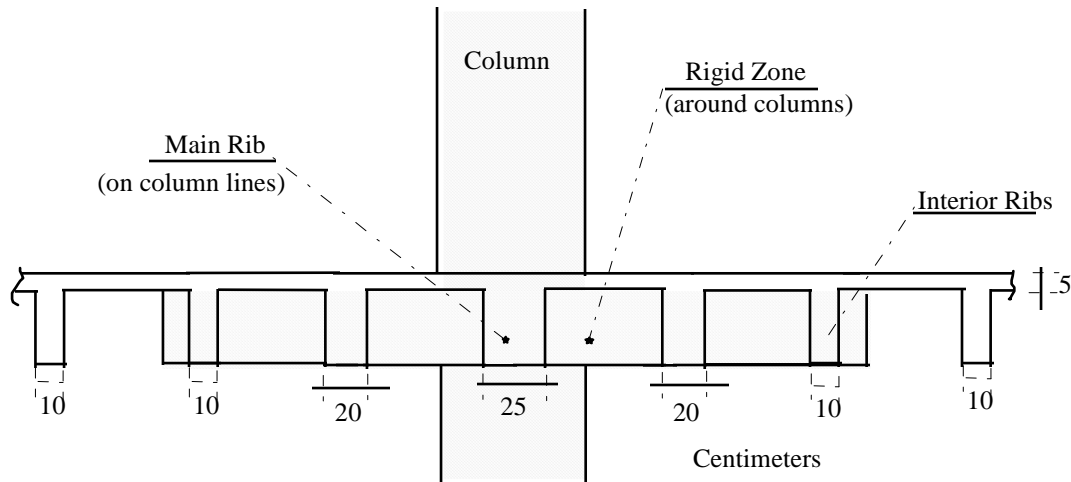

Figure 2.11 Typical Waffle slab section.

Waffle slab became very popular due to its ease in construction. However, since the total depth of the floor system is generally smaller than that in buildings with a flat slab and beams, a greater amount of reinforcement has to be used and building costs increase. The small slab depth also creates a problem of excessive lateral flexibility of the building under lateral forces.

Beam-Block Floor Systems

The beam-block floor system has become very popular in Mexico not only because of its constructability, but also because of its economy. The system consists of prefabricated prestressed beams that are used to support hollow sand-cement blocks which bridge the spaces between beams (Fig. 2.12). A 5 cm. reinforced concrete floor is cast on top of the beams and blocks to form a rigid diaphragm that can transmit forces to the lateral load resisting elements. Only a small number of shoring devices are needed to support the prestressed beams since these are placed directly on bearing walls or on main girders in the frame. Cost are reduced because the floor can be cast directly on top of the beams and blocks without formwork or shoring. The concrete floor is generally reinforced with welded wire mesh.

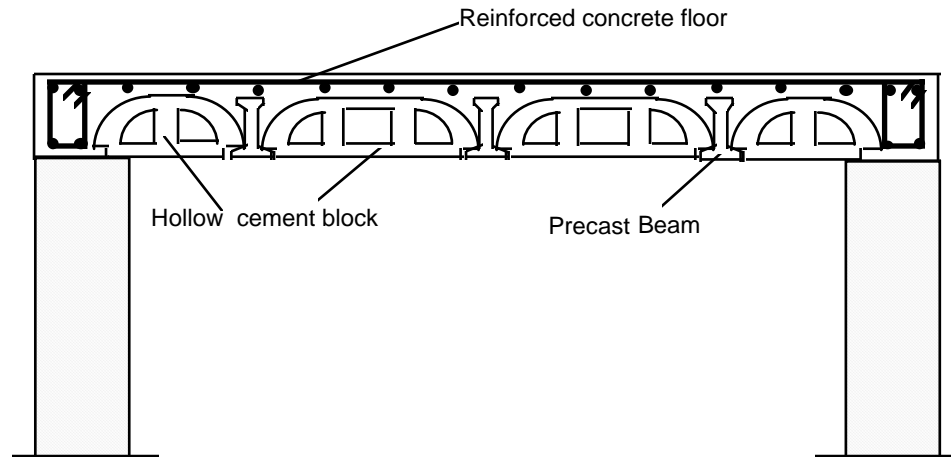

Figure 2.12 Precast beam-block floor system.

Dual Systems

These types of structures consist of moment-resisting concrete or steel frames, with flat or waffle slab, and other lateral force resisting elements in addition to the frames. Typical elements that are used for this purpose are steel or concrete diagonal braces and/or reinforced concrete or masonry structural walls, in one or both principal directions. Frequently, the walls form rigid boxes around elevator and stairway cores.

Good performance has been obtained with these buildings during earthquakes. Tall buildings such as the Pemex tower (52 floors, steel structure) or the Lomas tower (40 stories, reinforced concrete structure) have been built using dual structural systems [Fundacion 1988].

2.3 BUILDING DAMAGE IN THE 1985 EARTHQUAKE

2.3.1 Damage Statistics

Many of the engineered buildings that were seriously damaged during the 1985 earthquake were medium height buildings (6 to 15 floors) that had natural periods close to the dominant ground motion period. The dynamic response of these structures was greatly amplified. A 16 story building will rarely have an initial natural period lower than 1.8 sec. [Rosenblueth, et al. 1986]. Most of these structures were reinforced concrete buildings. Very few steel structures were severely damaged because steel is used mostly for taller buildings in which the dynamic response during the earthquake was lower than for medium height buildings. Buildings with masonry bearing walls performed quite well during the earthquake. Bearing wall buildings were generally less than 5 stories high and were much stiffer than framed buildings of comparable height.

Table 2.1 summarizes the information on 379 buildings that partially or completely collapsed or were severely damaged during the 1985 earthquake [Iglesias

and Aguilar 1988]. The buildings are listed according to structural type and number of stories.

Concrete buildings represent 86% of the total, 47% were built between 1957 and 1976, and 21% were built after 1976. Damage was concentrated in buildings with 6 to 15 stories (66%) and 93% of these mid-rise buildings were concrete structures.

TYPE OF STRUCTURE	EXTENT OF DAMAGE	NUMBER OF STORIES				TOTAL
		<5	6-10	11-15	>15	
R/C Frames	Collapse	37	47	9	0	93
	Severe	23	62	14	0	99
R/C Frames & Shear Walls	Collapse	0	1	0	0	1
	Severe	2	1	2	1	6
Waffle Slab	Collapse	20	31	6	0	57
	Severe	6	33	19	1	59
Waffle Slab & Shear Walls	Collapse	0	0	0	0	0
	Severe	0	2	3	0	5
R/C Frames & Beam-Block Slab	Collapse	3	0	0	0	3
	Severe	0	1	2	2	5
Steel Frames	Collapse	6	1	3	0	10
	Severe	0	2	1	3	6
Masonry Bearing Walls	Collapse	8	0	1	0	9
	Severe	19	1	1	0	21
Masonry B. Walls with R/C Frames in Lower Stories	Collapse	1	0	0	0	1
	Severe	3	1	0	0	4
TOTAL	Collapse and Severe	128	183	61	7	379

Table 2.1 Summary of Damage.

Table 2.2 lists the main modes of failure that were observed in the 1985 earthquake. The results were obtained from a survey of 331 buildings in the most affected zone in Mexico City that represented the majority of severely damaged or collapsed buildings [Meli 1987].

MODE OF FAILURE OBSERVED	% OF CASES
Shear in columns	16
Eccentric compression in columns	11

Unidentified type of failure in columns	16
Shear in beams	9
Shear in waffle slab	9
Bending in beams	2
Beam-column joint	8
Shear and bending in shear walls	1.5
Other sources	7
Not possible to identify	25

TABLE 2.2 Type of Damage [Meli 1987].

Structural configuration problems were a major cause of failure. Most configuration problems were associated with the contribution of non-structural elements to the building response, especially in corner buildings where two perpendicular facades were infilled with masonry walls, and the facades facing the street were left open. Of the buildings that suffered collapse or severe damage, 42 percent were corner buildings [Rosenblueth, et al. 1986].

Changes in stiffness or mass over the height of the building also were a contributing factor to the damage observed in the 1985 earthquake. Changes in stiffness were due to drastic changes in the structural configuration (wall discontinuities, column location), to a reduction in the size or the longitudinal and transverse reinforcement in columns, or to the location and number of infill walls. Abrupt mass changes were due to floor dead loadings which were considerably greater than that for which the building had been designed originally. Concentration of files in government buildings and stacking of materials in buildings used as warehouses were common causes of failure.

Building pounding was quite common during the 1985 earthquake because of the proximity of adjacent buildings. Recent codes explicitly limit the distance between buildings, however this limitation proved to be insufficient mainly because of the intensity of the ground motion and large inelastic deformations. Also, minimum spacing limitations between buildings stipulated in the code were not always met. In some cases, accumulation of materials during building construction filled the gap between buildings. Much of the column damage can be attributed to pounding especially when the slab levels of two adjacent buildings did not coincide.

The lack of sources of good quality aggregates for the production of concrete in Mexico City also contributed to a decrease in the modulus of elasticity of concrete. Such structures may have been more flexible than assumed in the Code. Because the elastic modulus was less than expected and because the elements were damaged during cyclic deformations, severe pounding problems were common [Rosenblueth, et al. 1986].

The contribution of P-delta effects on damage and collapse was evident since tilting and large story drifts were observed after the earthquake. The characteristic high flexibility of flat plate structural systems in Mexico City aggravated P-delta effects and in some cases was the cause of failure as could be observed by the position of the slabs after the building collapsed [Fundacion 1988].

2.3.2 Foundation Damage

In order to discuss foundation failures, the concept of failure must first be clarified. A foundation can be considered to have failed or to have sustained damage if differential or total settlements above the allowable have occurred even if the members that constitute the foundation have not experienced appreciable distress. Compared with the number of damaged superstructures, not many cases of foundation failures were identified after the 1985 earthquake. The following gives an overview of the damage observed in typical foundations in Mexico City.

Mat Foundations

About 17 mat foundations sank as much as 1.20 m. during the earthquake [Girault 1987]. The settlement was due primarily to the soil pressures developed as a result of the overturning seismic moments. Even before the earthquake, net soil pressures in some of the buildings were higher than allowed by the Mexico City Code. When the bearing capacity of the soil was exceeded with the addition of overturning moments during the earthquake, differential settlements were triggered. However, in many cases the damage can be attributed to poor foundation conditions since large settlements had already occurred before the 1985 earthquake.

Friction Pile Foundations

About 25 buildings with mat foundations supported on friction piles exhibited large settlements [Girault 1987]. In general, these buildings tilted as rigid bodies. Most of them were 9 to 20 stories high and are part of the group that was most affected by the ground motion. The maximum settlement, including settlements prior the earthquake, was 1.30 m. [Girault 1987]. The settlement that occurred after the earthquake was due to penetration of the piles into the soil and to failure of the clay under the mat foundation.

The capacity of the friction piles might have been reduced because the shear modulus of clay deposits degraded under large cyclic strains. However, most of the failures of friction piles were the result of an increase in axial force during the earthquake due to the overturning moments generated by the superstructure. In some cases, settlements might have been beneficial to the building since energy was dissipated in the foundation during the earthquake and the demands on the superstructure were reduced.

One special case is that of a 10 story building which overturned when its concrete mat foundation supported on friction piles failed. Some of the piles were pulled out of the ground and others broke under the tensile forces generated.

Point Bearing Piles

Point bearing pile foundations generally performed better than friction pile foundations although there were fewer buildings supported on this point bearing piles. In one case, a pile shear failure occurred because ground subsidence caused the piles to be unsupported laterally just under the foundation slab.

Control Pile Foundations

Some buildings supported on this type of foundation experienced significant tilting because of failure of the control (load limiting) devices at the head of the piles. Wood blocks used as control devices crushed in the first cycles of the earthquake and the load bearing capacity of the piles was no longer transferred to the foundation mats. Also, in some other cases the anchor rods, that connect the control device and the pile cap, buckled due to the lateral load induced during the earthquake (see "Building I" in Case Studies).

2.3.3 Structural Damage in Concrete Structures

For reinforced concrete structures, the damage can be classified depending on the element that was affected, namely beam, column, slab, beam-column joint, bearing wall, and wall damage.

Beam Damage

Diagonal cracking of beams near the beam-column connection was frequently observed. In some cases, crossing cracks due to stress reversal caused by cyclic loading were found. Also, there was concrete crushing near the connection on the bottom and top face of the beams due to the large flexural deformation during the earthquake.

Column Damage

Columns experienced diagonal cracking at midheight due to shear forces. The cracks formed crossing patterns due to the cyclic deformations to which the columns were subjected. Also, because of the large number of cycles of inelastic deformations, some columns experienced severe concrete deterioration, and lost vertical load capacity because of improper transverse reinforcement details. In many instances, ties were widely spaced and longitudinal bars were placed in bundles at the column corners, a practice that was permitted by the building codes. When the columns were subjected to cyclic loading, loss of bond around the steel bundles triggered a loss in column capacity and there was concrete spalling at the column corners. The longitudinal bars buckled

because the ties were widely spaced. In many cases column failure could be attributed to eccentric compression caused by the difference between the location of the column centroid and the beam longitudinal axis. The number of column failures far exceeded what would have been expected considering the intent of the 1976 Code (see Section 2.4) to provide ductile structures. Beam and/or slab over-reinforcement and the restraint provided by partial infill walls that were considered non-structural might have been two major causes of shear failures in columns.

Another common cause of column failure was the so called "short column" failure. The contribution of non-structural walls to the lateral stiffness of the building, was an important source of over strength in some cases but was detrimental in other cases where the walls infilled only a portion of the height of a story between column lines and reduced the unrestrained column length. As a result the effective stiffness of the column was increased and such columns "attracted" longer shear forces during the earthquake.

Slab Damage

Most of the damage that was registered in these elements was due to punching shear around the slab-column connection or around the column capital. In several cases diagonal tension cracks developed in the slab around the supports and suggested incipient punching failure. In cases where punching did occur, "pancaking" of the slabs in the upper floors of buildings led to total structural collapse. Yield lines in waffle slab systems were clear in several buildings and about half a dozen cases of complete punching failure of badly detailed waffle slabs were found [Meli 1987]. Shear cracks in the ribs of waffle slabs were common. Also, flexural hinging of the spandrel beams of flat plate systems was observed in some cases.

Beam-Column Joint Damage

Cracking and spalling of concrete in joints was observed in cases where no transverse reinforcement existed. Improper joint confinement was aggravated because the practice of using longitudinal bundled bars at the column corners reduced the confinement provided by longitudinal bars through the joint and led to increased joint spalling.

Concrete Wall Damage

Diagonal cracking of walls was common in buildings in which the walls restrained the lateral movement. Failure of non-structural walls in an asymmetric pattern was seen to have generated load paths quite different from that considered in the design and increased the distress on the structural walls.

CHAPTER 3

MEXICO CITY CODES AND REQUIREMENTS

3.1 CODES

Changes in seismic design codes have always been triggered by important seismic events because the deficiencies of these documents have been evident after damage was studied. Such was the case in the 1985 earthquake as Emergency Norms were published shortly after the event.

It is important to note that 58% of the collapsed or seriously damaged buildings in the 1985 earthquake were built between 1957 and 1976 and 17% after 1976 [Rosenblueth, et al. 1986]. To better understand the design provisions of Mexico City Buildings, a quick overview of seismic design changes since they first appeared in a Mexican code is appropriate at this point [Fundacion 1988, Meli 1987].

1942 Code

The 1942 code was the first Mexican code that explicitly included seismic design provisions. Its publication was the result of a major earthquake that occurred in 1941 with a magnitude $M_s = 7.7$ [Rosenblueth 1987]. However, the provisions were rather rudimentary and exempted buildings lower than 16 m. from seismic design. Seismic forces were obtained by multiplying the total building weight by a seismic coefficient depending on the building type and importance. For common apartment or office buildings, the seismic coefficient was $0.025g$ and was doubled for hospitals and other important structures. A 33% increase in allowable (working) stresses was permitted for the gravity plus earthquake load condition above that used for the gravity loads only.

1957 Emergency Norms

These were published after an earthquake which occurred on July 28, 1957, with a magnitude $M_s = 7.5$ which caused widespread damage to structures located in the soft soil zones of the city. Three types of soils were identified: soft, transition and hill zone. Structures were classified according to their importance and also to the type of structure used. Building importance (or use) was classified as follows:

Group A: Buildings of great importance for the safety of the population after an earthquake or with high density of users (hospitals, schools, theaters, police and fire stations).

Group B: Included most office, apartment buildings, and houses.

Group C: Structures which did not endanger human life.

Type of structure was classified into three categories:

Type 1: Reinforced concrete or steel structures with infill walls that contribute to the lateral stiffness of the building.

Type 2: The same structures as Type 1 but walls isolated from the frames (not contributing to lateral stiffness).

Type 3: Bearing wall buildings.

Seismic coefficients were assigned to each importance group and type of structure depending on soil conditions at the site. Table 3.1 lists the seismic coefficients used in the 1957 Code.

SEISMIC COEFFICIENT "C" (as a fraction of g)				
BUILDINGS IMPORTANCE GROUP	STRUCTURAL TYPE	SOIL CLASSIFICATION		
		A (soft)	B (transition)	C (Firm)
A	1	0.15	0.13	0.12
	2	0.20	0.18	0.15
	3	0.15	0.18	0.20
B	1	0.07	0.06	0.05
	2	0.10	0.09	0.07
	3	0.07	0.09	0.10
C	1, 2, 3	0	0	0

Table 3.1 1957 Code Seismic Coefficients [Fundacion 1988].

The contribution of infill walls to the lateral resistance was recognized. In order to protect structures against the consequences of brittle failure of the masonry panels, a double analysis was specified for these structures; first by taking into account the contribution of the walls, and second by assuming failure of the panels.

A 100% increase in the allowable working stresses for the gravity plus earthquake load condition was permitted, except diagonal tension for which the value remained at 33%. A maximum story drift of 0.2% was stipulated and structures taller than 45 m. required a dynamic analysis to determine the lateral forces. However, details on the way to perform this analysis were not stipulated in the code.

1966 Code

The development of the 1966 code began after the 1957 earthquake and was finished in the early 1960's, but was officially published and recognized in 1966. Microzonation was simplified and the transition zone was incorporated into the soft soil zone. Building groups and types were also modified from the 1957 Norms. The building groups remained basically the same, but a more explicit description of each group was given. Buildings in which public gatherings were expected were incorporated in Group A, and Group B buildings included those in which a high concentration of people was not expected. The building types were modified according to their structural characteristics: Type 1 was for framed systems with or without shear walls or braces, which were expected to deform mainly in flexure under lateral excitations. Frames with shear walls or braces had to be designed to resist 50% of the lateral force that would be expected if they were isolated from any bracing element. Type 2 was for structures with members that deformed under the action of constant stresses or axial loads, such as bearing wall buildings. Type 3 was assigned for inverted pendulum structures and structures without a rigid diaphragm capable of transmitting lateral forces to the resisting elements. The seismic coefficients for Group B structures are listed in Table 3.2. For Group A structures, the values in Table 3.2 were multiplied by 1.3 and for Group C, a seismic design was not required.

SEISMIC COEFFICIENT "C" (as a fraction of g)-GROUP B			
STRUCTURE TYPE	1	2	3
SOFT SOIL	0.06	0.08	0.15
FIRM GROUND	0.04	0.08	0.10

Table 3.2 1966 Code Seismic Coefficients for Group B structures[Fundacion 1988].

The allowable stress increase that was stipulated for the vertical plus lateral load condition was dependent on the material used in the structure. For wood and steel structures a 50% increase was permitted, whereas only an increase of 33% was allowed for concrete and masonry structures.

Three types of seismic analysis were recognized in this code: a simplified static analysis that was used for one or two story bearing wall structures to check the shear resistance of the walls; a static analysis in which the seismic forces were varied linearly along the building height, and the base shear was computed by multiplying the seismic coefficients given in Table 3.2 by the total building weight (including live loads); and a dynamic modal analysis using design spectra corresponding to the microzonation of the

city and including structural damping. The seismic forces obtained in the dynamic analysis had to be at least equal to 60% of those calculated from the static analysis.

The story drift limits imposed in this code were 0.2% for buildings in which the non-structural elements were not properly isolated from the structure; and 0.3% (soft soils) and 0.4% (hard soils) for buildings that could deform without any non-structural restraint. The minimum separation between adjacent structures was stipulated as the greater of 5 cm. or the computed top displacement increased by a factor times the building height. For buildings in the highly compressible soil zones this factor was 0.006 and for buildings in low compressibility soil zones it was 0.004.

1976 Code

A set of complementary technical norms pertaining to the design and construction of the most commonly used materials in Mexico City (wood, masonry, steel, and concrete structures) were added to the 1976 Code. The soils were again divided into three zones depending on the thickness of the highly compressible upper strata.

An elastic seismic coefficient was assigned for each type of soil as a percentage of the gravity acceleration. For the soft, transition, and hill zones, values of 24%, 20%, and 16 % of g . were used respectively. The forces obtained with these coefficients were reduced by a ductility factor (Q), recognized for the first time in a Mexico City code. The ductility factor had values ranging from 1 to 6 depending on the ductile behavior expected for the type of structure used. A value of 6 was given to steel or concrete structures which satisfied a set of requirements intended to prevent brittle failure, local buckling, and deterioration of force-displacement curves. For framed structures which did not meet all of these requirements, or for structures that had shear walls or bracing elements, a ductility factor of 4 could be used, as long as the frames in the building were capable of resisting 25% of the story shear by themselves. For concrete or steel framed structures that did not meet these requirements, or for buildings having unreinforced masonry walls as lateral resisting elements, a value of $Q = 2$ was specified. If the masonry walls were constructed using hollow concrete blocks, the ductility factor allowed was 1.5, and for other types of structures, no reduction was permitted. No specific mention was made of the value to use for waffle slab construction but these were usually designed using $Q = 4$.

The requirements for $Q = 6$ were rather stringent and difficult to satisfy. A value of $Q = 4$ was used instead. However, detailing requirements for $Q = 4$ were not as strict as those for $Q = 6$, and many times were only slightly different from those required for gravity loads. The result was that deformation capacity of the structure using a value of $Q = 4$ was reduced because confinement requirements were more lenient for gravity loads. Bar bundles were permitted in the columns, but a limit of four bars per bundle was set. For waffle slab systems, moments were distributed to middle and column strips using factors of 0.4 and 0.6, respectively. For the column strips, at least 25% of

the reinforcement had to be placed in a region that extended one effective depth on each side of the column face, a requirement which was often neglected.

Again, three analyses were specified by this code. A simplified static analysis was permitted for structures up to 13 m. tall. A static analysis was allowed for structures up to 60 m. tall using reduced forces based on ductility factors for each type of structure. A dynamic analysis could be performed using design spectra specified for each type of soil or by a step by step integration procedure, using a minimum of four representative accelerograms. The 1976 code design spectra for different soil conditions are shown in Figure 3.1.

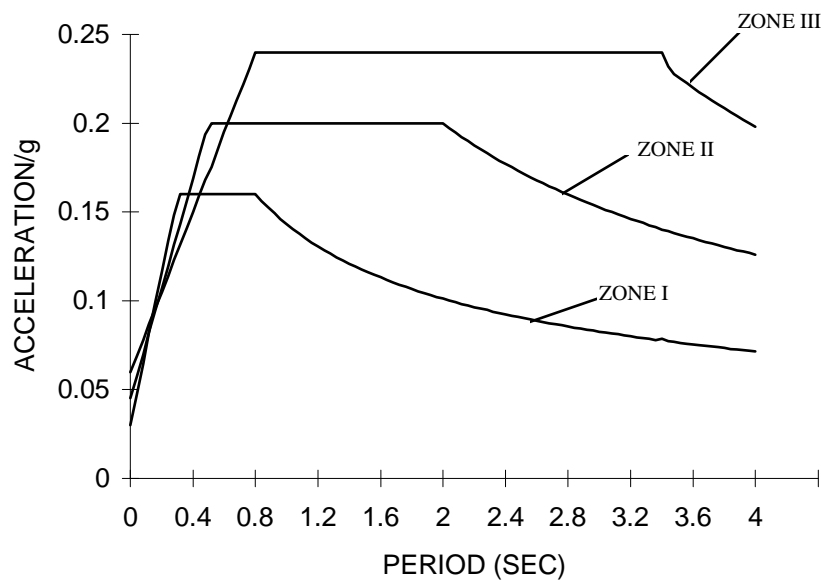

Figure 3.1 1976 Code Design Spectrum.

Structural displacements were computed by multiplying the elastic displacement by the ductility factor used for the building being analyzed. An accidental eccentricity of 0.10 times the floor dimension perpendicular to the direction of analysis was specified to take into account torsional effects. This represented a twofold increase from the 1966 code which set the accidental eccentricity equal to 0.05 times the floor dimension.

Story drift limits were increased to 1.6% for buildings with non-structural elements properly isolated from the lateral load resisting elements, and to 0.8% for other cases. Building separations had to be at least equal to the top story displacement increased by a factor times the total height of the building. This factor had a value of 0.001, 0.0015, or 0.002 for structures located in firm, transition, or soft soil zones.

1985 Emergency Norms

These were published shortly after the 1985 earthquake to assure that the repair of structures was performed satisfactorily. The most important changes from the 1976 Code included an increase in the elastic seismic coefficients to 0.40 g. and to 0.27 g. for lake bed and transition zones. The ground accelerations for soft and transition soils were also increased to 0.10 g and 0.05 g. The resulting values were not as large as values from the acceleration spectrum obtained using the SCT record for 5% of critical damping (see Fig. 2.2). Since the forces were expected to be reduced by inelastic energy dissipation, the ductility factor of 6 was eliminated, and the requirements for the use of $Q = 4$ became more stringent to insure ductile behavior of the structure by improving column confinement. Frames having shear walls or braces had to be designed to resist at least 50% of the story shears when isolated from the wall and bracing elements.

The strength reduction factor for column design was lowered from 0.75 to 0.50 when the ductility factor used was greater than 2. The minimum tied column dimension was increased to 30 cm. and spacing between ties was reduced. Also, unrestrained longitudinal column bars had to be at a distance no greater than 15 cm. from properly tied bars, and ties had to be at least #3 bars.

For flat slab systems, 75% of the reinforcement required to resist moments due to lateral forces had to be placed within the column width, and the rest within a distance no greater than 1.5 times the slab effective depth on each side of the column face. Live loads were doubled to take into account the great number of failures due to overloads. Important sections were added to the design requirements for piles, limiting damage due to differential settlements, minimum separation between buildings, connection detailing, and construction supervision.

1987 Code

This code was adopted on July 3, 1987, and included many provisions that were stipulated in the 1985 Emergency Norms. There were several changes made including microzonation of the city. The soft soil zone was redefined. Also building Group C was eliminated, but Group B was subdivided into two Groups B1 and B2 depending on location and building area. The importance of defining a regular structure from an architectural point of view was explicitly stipulated.

Most of the seismic design provisions were published in the body of another document called Complementary Technical Norms for Seismic Design, but generic aspects such as the seismic coefficients and different load combinations remain in the code. The seismic coefficients for the different subsoil conditions in the city were fixed at 0.40, 0.32, and 0.16 g. for the soft, transition and hill zones. The importance factor for Group A buildings was raised to 1.5 instead of the 1.3 used in previous codes. For rehabilitation of existing buildings the same seismic forces are used as those for new buildings.

The Code recognizes two zones of high seismic risk in the central and southern lake bed zone including, in the South, some of the transition soil zone. However, the same seismic coefficient as the rest of the lake bed zone is specified.

Interstory drift was limited to 0.6% for buildings in which the non-structural elements were not properly isolated from the lateral load resisting elements, and to 1.2% if the building deformations do not affect non-structural elements. Building separation was specified as the sum of the calculated lateral displacements for each building and 0.001, 0.003, or 0.006 times the total height for firm, transition and soft soil sites, respectively.

Ductility factors from the Emergency Norms remained but under a different name: Seismic Behavior Factors. The smallest seismic behavior factor obtained in a given direction had to be used for all the floors of the building. More stringent measures for design and for construction supervision for Group A and Group B1 structures were implemented. The equivalent static method for seismic design was limited to structures having a height not exceeding 13 m.

Recommendations were made for including soil-structure interaction in modal seismic analysis of buildings (included in an appendix). The natural soil periods of the building site had to be considered. Also, there were new provisions for foundation design based on experience from the 1985 earthquake.

Better quality control was required for the materials used in the fabrication of concrete for buildings in Groups A and B1. There were also changes made to the strength reduction factors and in detailing requirements to insure ductile behavior of rigid frames. Steel structures had to be designed according to factored loads and strength provisions instead of allowable stresses as in the 1976 Code [Fundacion 1988].

In 1993 a new version of the Mexico City Code was issued [Departamento 1993]. This version introduces changes only on legal and administrative aspects of construction. The 1987 Complementary Technical Norms for Seismic Design remain in effect. However, the "Instituto de Ingenieria-UNAM" published a new version of the Norms proposing some changes. Two of the most important are enlarging the zone of high seismic risk in the central area of the lake bed and elimination of the alternative to reduce seismic forces by using site specific spectra.

3.2 POST- EARTHQUAKE STABILIZATION REQUIREMENTS

For buildings damaged in an earthquake The Emergency Code following the 1985 earthquake required lateral resistance of 25% of specified values. The enforcement of this requirement was not uniform or rigorous. The temporary measures adopted for many buildings were often "non-engineered" and provided little more than "psychological support".

In the 2 to 3 years after 1985, most damaged buildings were retrofitted or demolished. Subsequently, many additional non-damaged special (Group A) or critical (hospitals, schools, communication centers) were rehabilitated voluntarily as owners decided to reduce the possible vulnerability of their structures in future events.

3.3 EVALUATION PROCEDURES

After the 1985 Earthquake in which a number of buildings were unnecessarily destroyed or condemned, The Government of the City established a rapid survey procedure for future events. The procedure was based on studies of the Cuauhtemoc District which was in the most damaged region of the city [Norena et al. 1989].

The procedure is based on a census of buildings in a given area. The address, number of floors, use, damage potential (related to height) are recorded. Data from the 1985 Earthquake for the buildings reported with any type of structural damage (slight, severe or collapse) in Cuauhtemoc District is shown in Tables 3.3 and 3.4 [Norena et al. 1989] [Iglesias and Aguilar 1988].

The results show that high density use buildings (hospitals, offices) were most affected in 1985. Importance was established on the basis of height and use (Fig. 3.2).

Use of Damaged Buildings in the Cuauhtemoc District of Mexico City			
Use	Damaged buildings	Total buildings	% Damaged buildings
	Cuauhtemoc District	Cuauhtemoc District	Cuauhtemoc District
Hospitals	94	389	24.2
Offices	265	2333	11.4
Schools	51	619	8.2
Housing	833	30887	2.7
Entertainment	3	138	2.17

Damaged Buildings in the Cuauhtemoc District of Mexico City				
Stories	Damaged buildings		Total buildings	% Damaged buildings
	City (total)	Cuauh. D.	Cuauh. D.	Cuauh. D.
1-2	1160	617	31574	2.0
3-5	577	342	11975	2.9
6-8	268	206	1439	14.3
9-12	215	168	456	36.8
>12	83	64	181	35.4
TOTAL	2303	1397	45625	

Table 3.3 Buildings with structural damage in Cuauhtemoc District.

Commercial	138	6756	2.04
Tourism	7	837	0.84
Others	0	834	0.0
No use	6	2832	0.21
TOTAL	1397	45625	

Table 3.4 Use of buildings with structural damage in Cuauhtemoc District.

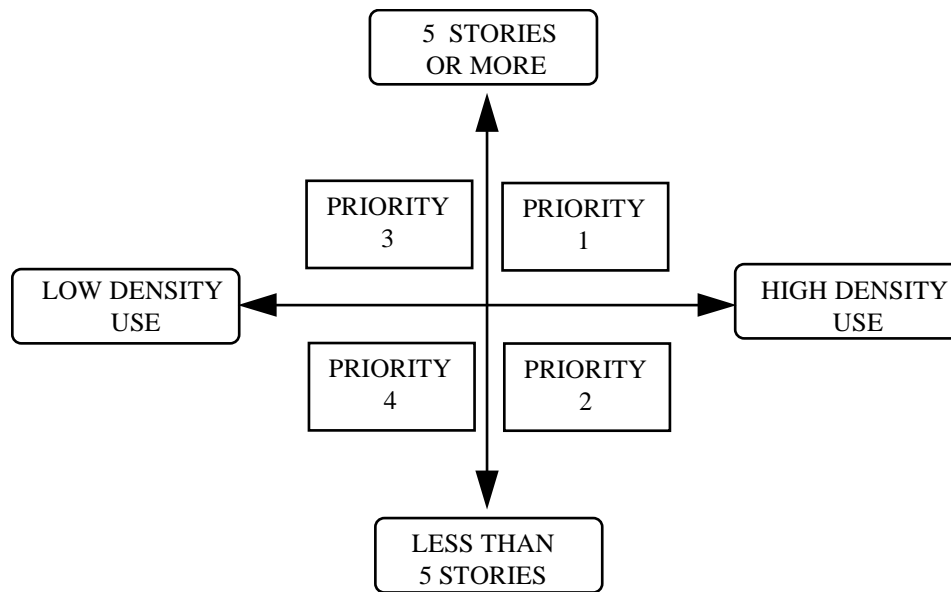

Figure 3.2 Importance of buildings according to height and use.

Buildings with high density use and with 5 or more stories, considered as first priority, were evaluated in three stages:

First Level Evaluation.

Visual inspection only was required with emphasis on location of lateral force, resisting elements and stiffness.

- Structural configuration (plan, elevation)
- Foundation
- Location in seismic zoning
- Deterioration (previous earthquakes, age, maintenance).

Based on this information a building index between 0 (zero) and 10 was assigned. Buildings with an index above 3 were reviewed according to the second level evaluation.

Second Level Evaluation.

Calculation of lateral capacity was required with a more detailed inspection of building, dimension of elements, previous damage, or repair. The lateral capacity was based on a simplified evaluation of the seismic capacity of medium-rise concrete buildings developed by Iglesias [1989]. For buildings by more than 10 floors, this evaluation was complemented by an estimation of the fundamental period. The building resistance was compared with required capacity according to type of structure and location.

Third Level Evaluation (Detailed evaluation).

If previous evaluations indicate need for strengthening, the Government of the City requested that the owner rehabilitate the building according to the new Code. In most cases, the owners complied with the requests.

The process was extended to districts beyond Cuauhtemoc and the census included most buildings of high-density use and more than 5 floors in the lake bed zones. Several buildings which were classed as dangerous after detailed evaluation were required to be retrofitted by Mexico City officials. However, financial constraints did not permit construction to be carried out in some cases.

Rehabilitation projects involving damaged buildings, rehabilitation design projects of undamaged buildings, and new buildings with more than four floors had to be approved by the Building Coordination Office of the City. This office sent the projects to private consultants for review and comment. In most of the cases this procedure was well received by the designers, especially for the rehabilitation projects. Professional conflicts were created only in a few cases.

The evaluation system was in effect for about three years and was canceled in 1989 by a newly elected government of the City.

3.4 INSPECTION AND SUPERVISION OF PROJECT

At the time a permit is issued for construction or rehabilitation, a Building Director is identified. The Building Director is licensed by a City Commission. This Commission is formed by eleven members; two members representing the government of the City, seven members representing different engineering and architectural professional associations, and two members representing consulting and construction companies.

The Commission establishes credentials, and reviews candidates. A candidate must have an engineering degree and 5 years of experience. The Commission can require an exam or evaluation of credentials. The Commission grants a 3 year license.

After the 1985 Earthquake, the 1987 Code added the requirement that a “Co-responsible” is needed for the areas of structural safety, architectural issues, and installations for buildings higher than 30 m. in the hill or transition soil zone, or higher than 15 m. in the lake bed zone. For each area a nine member technical commission issues licenses which may require a written exam and a follow-up oral exam. About one-third of those applying in the area of structural safety are rejected. The structural co-responsible is in charge of field inspection and verification of materials and soil testing.

For importance Group A buildings, an evaluation is required every 5 years with a report filed by a structural co-responsible. After an “intense earthquake” a co-responsible must evaluate the building [Departamento 1993]. The building owner pays for the report. It should be noted that Group A buildings had to be upgraded to 1987 Code requirements even if no damage was observed. The owner was responsible for the cost of upgrading.

After the 1985 earthquake, the 1987 Code required the owner to be responsible for maintaining plans and other pertinent information on his buildings. If plans were not available, the initial conditions (at time of evaluation) establish the record which is then up dated at 5 years intervals. However, in practice these rules may not be “triggered” until a building changes ownership.

CHAPTER 4

GENERAL REHABILITATION TECHNIQUES

The rehabilitation techniques described in this chapter have been used to repair earthquake damaged structures in Mexico City. The selection of a particular procedure depended on the objectives to be satisfied in retrofitting a structure and on the designer's experience in the matter. However, in almost all the cases, the desired solution was obtained by combining several of the techniques available. Among the objectives that structural engineers looked for when designing a retrofitting scheme were restoration or increase in strength, stiffness, or ductility of critical members in the structural system or of the overall structure.

Concern for life safety led to the upgrading of undamaged structures to new lateral force levels specified by codes. However, in Mexico City, most of the structures that have undergone rehabilitation to date were damaged either during the 1985 earthquake or in a previous event.

4.1 MATERIALS USED IN REPAIR

The repair materials that were used in Mexico City had to meet the following characteristics [Teran 1988]:

1. Be durable and protect reinforcement.
2. Be dimensionally stable to avoid loss of contact between the old and new materials due to shrinkage.
3. Provide good bond between the new and old materials, including bond between steel and concrete elements.
4. Be able to develop adequate resistance at early ages, especially if the capacity of a damaged element had to be restored rapidly.

The properties of repair materials had to be similar to the existing material properties to avoid creating overstresses in the old material. The elastic modulus and time or temperature effects on the materials had to be compatible with existing materials to avoid problems under high stresses, sustained loads, or temperature changes [Teran 1988]. In the case where new concrete was used to repair an element, the new concrete compressive strength was at least equal to the existing concrete strength. However, the difference in strength had to be given special consideration to avoid failure and crushing in the lower strength materials. Some comments regarding specific material are included in the following sections.

4.1.1 Resins

Resins were generally used to repair cracks or to replace small quantities of damaged concrete. They were also used to anchor or to attach new steel and concrete elements because of the high bond characteristics of the material. In Mexico City, there was not much experience using this material for construction and many projects were done without qualified supervision.

When the two components of a resin (epoxy, polyester, acrylic, polyurethane, etc. and catalyst) are mixed, the resin transforms from a plastic state to a hardened state. In the plastic state, resins may vary in viscosity, setting time, minimum curing temperature, degree of sensitivity to moisture, and color. Flexural, tensile, and compressive strengths are usually higher than the values attainable by concrete [Murray 1981].

Special attention had to be given to the selection of the type of resin based on the compatibility of its properties with the existing concrete and on the environmental conditions encountered. It has been reported that, in general, the properties of resins deteriorate above 100°C and the hardening process is suspended at temperatures below 10°C. If moisture is present, resins that are insensitive to moisture are recommended. Heat is produced by the chemical reaction between the resin and the catalyst and could increase shrinkage and loss of bond with the old material if resins are used in warm weather and curing is not controlled.

Some properties of resins that made them a viable alternative as a repair material are: excellent bond to concrete, masonry, and steel; high strength and hardness; resistance against acid, alkali, and solvent attack; low shrinkage, and good durability. On the other hand, properties which might impair the behavior of resins as a repair material are: their loss of integrity at temperatures above 100°C and the limited time available to place resins once both components have been mixed since hardening takes place in a short time.

4.1.2 Concrete

Cast in Place

Concrete was widely used as a repair material to replace damaged sections, increase the capacity of an element, and/or add new lateral force resisting elements to an existing structure. However, to obtain satisfactory behavior of a repaired structure, monolithic action between the new and old materials had to be achieved. The change in concrete volume or shrinkage during the hydration process was the main problem encountered when using concrete for repairs because a loss of contact between the new and old material surfaces might impair transfer of stresses. In some cases, shrinkage was controlled with the use of volume stabilizing additives in the mix.

Also, existing concrete surface preparation was recommended to increase bond between the materials. Roughening of the old concrete surface was generally performed. The old surface was saturated prior to casting the new section to avoid

water loss from the fresh mix to the existing section. Resin or a water-cement mix on the old concrete surface was sometimes applied to improve bond between the two materials [Iglesias, et al. 1988]. However, there is little experimental information that this procedure is necessary.

Placement of concrete was often difficult because of reinforcing steel congestion. Also, in many cases casting had to be performed through holes bored in the existing structure specially in slabs. Workability of the concrete mix was fundamental for placement in congested areas. The use of superplasticizers was advised to keep the water/cement ratio low to maintain strength and to reduce shrinkage effects [Teran 1988]. Care was taken in selecting the maximum aggregate size that would pass between bars or openings to insure a uniform distribution of the mix. Vibration was critical to avoid creating air pockets or exposing aggregate in the mix.

Shotcrete

Shotcrete was used to repair and strengthen concrete and masonry walls and to jacket concrete elements. Among the main advantages of using shotcrete were minimum formwork, generally good bond to existing concrete, and high strength. However, special equipment and trained personnel (nozzlemen) were required for the use of shotcrete. It has been reported that the nozzleman's ability and expertise determines the effectiveness of the process [Moore 1987].

The shotcreting procedure involves mixing sand and cement pneumatically with water and shooting the material into place at high velocities through a hose. In the dry-mix process, sand and cement are mixed together and carried through a hose by compressed air. Water is added under pressure at the nozzle and the mixture is jetted to the surface being shotcreted. The nozzleman controls the water content of the mortar and can vary the water/cement ratio depending on the field conditions. In the wet-mix process, the water, cement, and aggregate are mixed before pumping. The nozzleman has no control over the material properties. The wet-mix process has the advantage of reducing rebound and eliminating dust, but the water/cement ratio is increased yielding a lower strength material.

Rebound and overspray are two problems that result from the shotcreting process. Rebound is aggregate that does not adhere to the surface and falls away from the fresh material. Overspray results from a large amount of pressurized air used in the procedure, resulting in a mix with large quantities of air pockets [Moore 1987]. Both of these conditions deteriorate the durability of shotcrete because of the creation of sand pockets that allow the infiltration of water into the material. Placing of shotcrete behind reinforcing bars poses another problem. Good consolidation behind bars is highly influenced by the operator's ability in placing the material.

Shotcreting was used to repair horizontal, vertical, diagonal, or overhead surfaces. The concrete surface was prepared prior to shotcreting in the same manner as for cast in place concrete to enhance bond between the two materials. In general,

examination of shotcrete in projects in Mexico City indicated good bond to the existing concrete.

Resin Concrete

Resin concrete was obtained by substituting the cement in the concrete mix with resins (epoxy, polyester, acrylic, methacrylate, etc.). Resin concrete was used to patch small areas of damaged concrete (popouts). The advantage of resin concrete was that high strengths could be reached quickly of time and excellent bond was attained if applied to a clean, dry concrete surface [Teran 1988]. To improve bond, a layer of resin was applied to the concrete surface before placing the resin concrete.

Disadvantages of resin concrete include low resistance to heat and low modulus of elasticity compared with portland cement concrete.

4.1.3 Mortars and Grouts

Grouts are a mixture of sand, cement, and water used to repair cracks in damaged concrete or masonry elements. Grouts were poured or injected into the crack depending on the extent and accessibility of the damage. Forms or sealers had to be used to contain the grout until it had set. The amount of water in the mortar influenced the workability of the mix and the amount of shrinkage during hydration. To improve workability and to reduce shrinkage, the use of volume stabilizer additives and superplasticizers was recommended [Iglesias, et al. 1988]. Grouts were also used to anchor dowels to existing concrete elements.

Cement milk (a cement-water fluid) was used to inject cracks up to 0.5 mm. It was also used as surface preparation before casting new concrete against an existing surface to improve bond.

The use of epoxy grout was suggested when high shear force transfer, low shrinkage, and positive bond were required. The combination of epoxy with sand fillers yielded a material with a higher modulus of elasticity [Teran 1988]. Epoxy grouts developed full strength at early ages and could be exposed to service life conditions in a few hours. Epoxy grout were used effectively in Mexico City for anchorage of dowels and other metal connectors to concrete.

Dry pack is a sand-cement mix with minimum water content used to repair gaps or voids by bond. The material had to be packed into position and the resulting repair was dependent on workmanship and on the space available to insure uniformity and good consolidation.

4.1.4 Steel Elements

Steel reinforcement was used to replace damaged bars in concrete elements. To insure continuity, splices, mechanical connectors, or welding was performed. If

welding was used, the heating and cooling processes had to be controlled to avoid changing the material properties to a brittle mode of failure. The added elements had to be protected against corrosion and fire exposure.

Structural steel was used to restore and upgrade the strength of damaged concrete elements. Angles and plates were used to jacket concrete columns and beams. Plates were also bonded with epoxy to the face of elements to increase flexural capacity.

4.2 LOCAL STRENGTHENING OF ELEMENTS

Local strengthening was employed to restore or increase the strength of damaged elements without changing the basic concept of the original structure, that is, the load paths of the original structure were not modified. Damaged elements had to be repaired by means that restored the in original properties. For cases in which there was significant damage to the original element, material substitution was the most advisable solution. For other cases, procedures that reestablish monolithic behavior between the damaged parts by substitution of small quantities of the original material were recommended. In any case, the solution that was adopted had to comply with the strength, stiffness, and/or ductility requirements, if any. Many of the procedures described above can provide strengths higher than the original element, but the stiffness obtained will generally be lower than the stiffness of the undamaged structure. Proper structural behavior is more easily realized by assuring that monolithic behavior between the new and existing materials takes place. Behavior was improved with the use of bonding materials (resins), surface roughening, and other procedures which are described in more detail in the following sections.

4.2.1 Injection

Injection was used widely to repair damaged concrete elements in which no significant deterioration of the concrete matrix was observed. Cracks were injected primarily to restore some of the element stiffness although it was difficult to reach the stiffness prior to damage. It has been reported that 70% to 80% of the original stiffness and the original element strength can be attained [Iglesias, et al. 1988]. Injection was performed under pressure depending on the width of the cracks that were repaired. Devices as simple as caulking guns were used to inject materials into cracks but there were others in which the materials were mixed according to manufacturer's recommendation.

It has been recommended in the literature that for cracks ranging from 0.1 to 0.5 mm., resins without a filler may be used. For wider cracks, a filler must be added to reduce shrinkage, creep, and thermal phenomena. For cracks ranging from 1.0 to 1.5 mm., resins can be mixed with glass or quartz powder, and from 1.5 to 5.0 mm., sand can be used in the mix [Teran 1988].

4.2.2 Material Substitution

Materials were replaced when the extent of damage was such that simple injection would not insure proper repair. Damage involving crushing and spalling of concrete, and/or buckling and fracture of longitudinal or transverse steel required replacement. All damaged material had to be removed and new material placed with properties compatible with the original material properties. To insure monolithic action, surface preparation was recommended.

The element was unloaded by shoring or cribbing so that damaged materials could be removed until sound material was encountered. In cases where concrete spalling and cracking of the concrete core had occurred, a combination of injection and material substitution was used. The old concrete surface had to be cleaned removing any loose particles prior to casting the new material. Surface roughening with hand tools or sandblasting was also advised to enhance monolithic behavior. After the concrete surface was cleaned, it was saturated before casting new concrete. Expansive admixtures were used in the concrete mix to avoid shrinkage and minimize loss of bond. Formwork and casting operation were organized so that the concrete could be consolidated adequately against all surfaces including overhead sections. After stripping the forms, any excess concrete was removed while the strength was low. This procedure worked well when chutes or flared forms were used to place concrete.

Replacement of buckled or fractured reinforcing bars was done by substituting new bars for the damaged segments. Continuity was provided with splices, mechanical connectors, or welding. If welding was performed, pre-heating and cooling procedures had to be considered to avoid creating a brittle material failure. Figure 4.1 shows two columns with different levels of damage [Iglesias, et al. 1988]. In some projects where the slabs had large deflections, shoring and jacketing were used to realign floors to original height. In the first case, only concrete has spalled on the exterior and the core shows some cracking. Cracks are injected with epoxy, and the spalled concrete is replaced with new material. The second case shows a column with buckled and fractured reinforcement. In this case, the damaged portion of the bars is removed and new bars are spliced to the original undamaged reinforcement. Additional ties are placed to improve confinement and the concrete cover is cast on top of the repaired section.

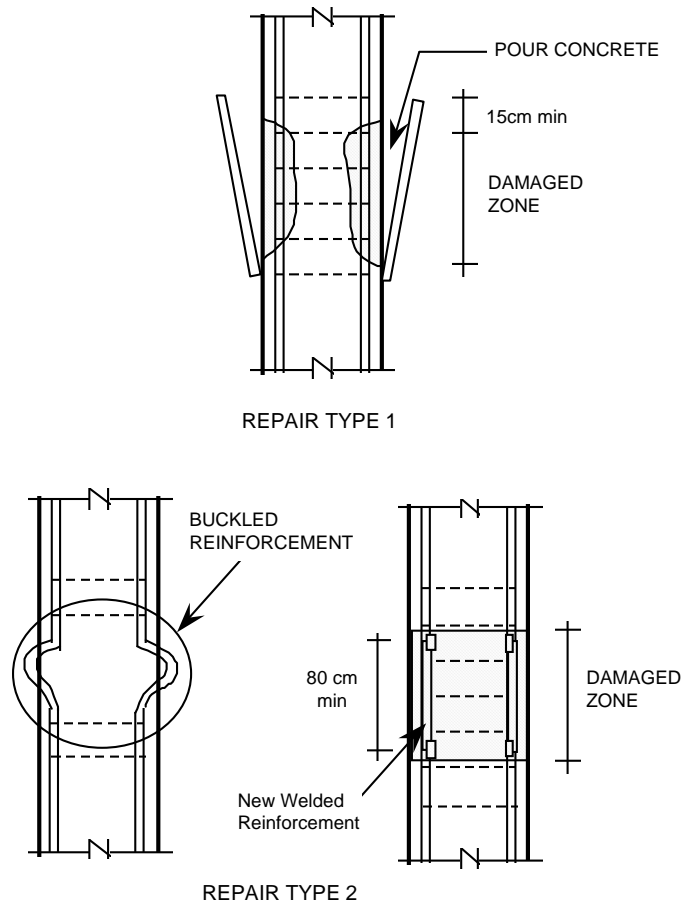

Figure 4.1 Material substitution.

The procedures shown could be implemented for other elements as well, such as beams, walls, or slabs. A new concrete topping slab reinforced with a welded wire mesh cast directly on a damaged slab may be quite economical and should perform well without removing the damaged material in the slab [Teran 1988].

Severely damaged masonry walls required substitution of some bricks or blocks. Removal of blocks adjacent to cracks was necessary to place the new elements and obtain good bond with the existing materials. The use of a high cement content mortar was recommended for good behavior after the repair. In some cases it was advised to add reinforced concrete elements to increase the out-of-plane strength and stiffness of masonry walls to avoid lateral overturning.

4.3 REHABILITATION TECHNIQUES

4.3.1 Modification of Existing Elements

Concrete Jacketing

Concrete jacketing was used to increase axial, flexural, and shear strength of existing elements. Increases in ductility and stiffness were also achieved. Jacketing was performed by adding longitudinal and transverse reinforcement or a welded wire mesh surrounding the original section and covering it with new cast in place concrete or with shotcrete. Surface roughening of the original section was performed by sandblasting or by mechanical means to improve monolithic behavior of the elements.

Columns

Column sections were increased by adding materials to only one or to several faces of an existing column depending on accessibility. However, for better performance, complete jacketing or encasement is recommended. Longitudinal reinforcing steel was placed at the corners to keep the additional transverse reinforcement in position. If more than four bars were used, care was taken to place the bars at positions that would not intersect the existing beams to minimize constructability problems. To increase flexural strength, as well as axial and shear capacity, longitudinal bars were often continuous through the floor slabs. Concrete was then cast through holes bored in the slab. Fig. 4.2A shows the longitudinal bar distribution that can be used to minimize holes drilled in the existing beams.

Welded wire mesh was used primarily to increase the shear and axial strengths and the ductility of columns. The mesh was not passed through the floor (Fig. 4.2B). The shotcrete was used to increase the speed of construction.

When material was added to one, two, or three faces of the existing column, special ties were used to confine the added longitudinal reinforcement. The ties had to be anchored effectively to the existing reinforcement as shown in Fig 4.3, either by hooking the tie around the longitudinal bars, or by welding it to the reinforcement. The existing column reinforcement was exposed by hand chipping or by jack hammering or other power devices.

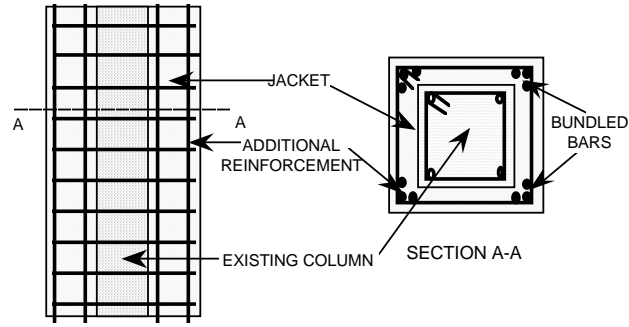

A) JACKETING WITH LONGITUDINAL REINFORCEMENT

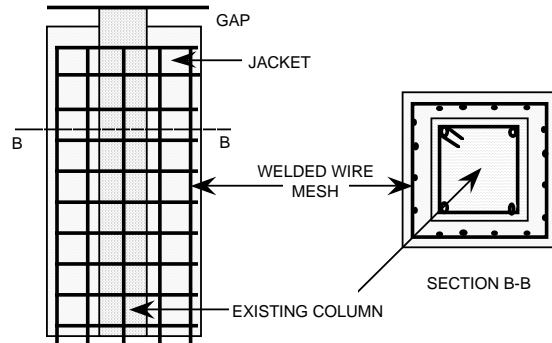

B) JACKETING WITH WELDED WIRE MESH

Figure 4.2 Column jacketing.

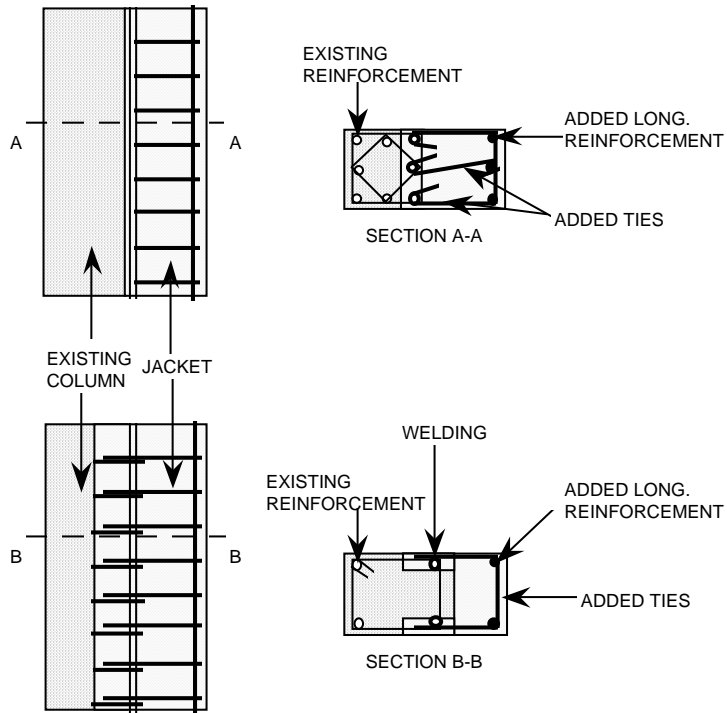

Figure 4.3 One face column jacketing.

Beams

Jacketing of beams to increase shear and flexural capacity followed the same general procedures described above for columns. If only the positive flexural strength had to be increased, the jacket was placed on the bottom face of the beam as shown in Fig. 4.4. Ties were provided for confinement of the longitudinal bars.

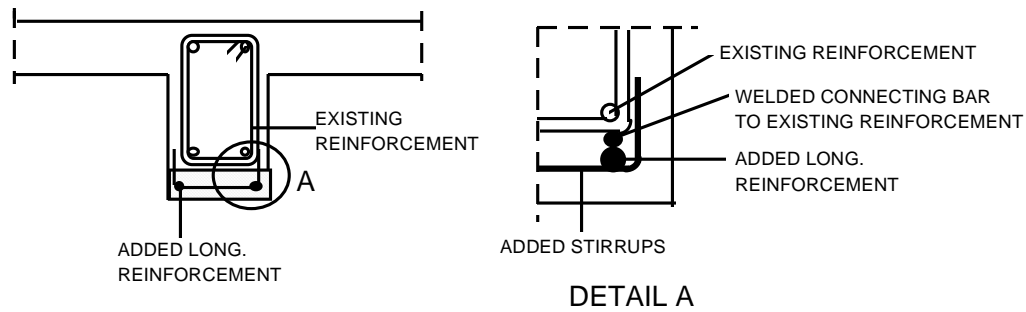

Figure 4.4 Bottom beam jacket.

To be able to develop yield in the longitudinal bars, continuity had to be provided at the ends of the beam. This was done by making the reinforcement continuous through the column core or by anchoring the reinforcement to column collars. There were cases in which the longitudinal reinforcement in beams was bent around the original column, but the effectiveness of this procedure has yet to be evaluated (Fig. 4.5). If the jacket was placed on three or four faces of the beam, then flexural and shear capacities were increased. Holes had to be drilled in the existing slab to pass the transverse reinforcement as shown in Figure 4.6. If the top face of the beam was also jacketed, new top bars were added to increase the negative flexural strength. Casting was usually performed from above through holes in the slab.

Figure 4.5 Beam and column jacket.

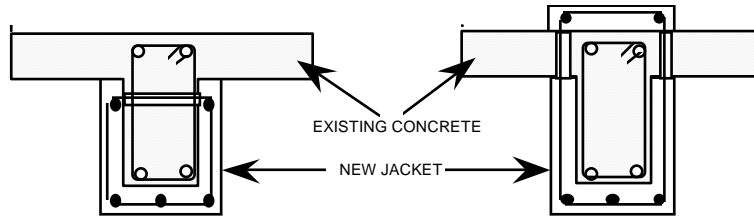

Figure 4.6 Three and four face beam jacket.

Steel Jacketing

Properties of elements can be restored and even enhanced with the use of steel elements surrounding the section.

Effective contact between the steel elements and the concrete surface was required for the repair to be successful. Contact was achieved by using concrete or resin grouts between the two materials. If cement grouts were used, expansive additives were included to reduce shrinkage. Recommendations regarding the use of resin grouts followed the same guidelines as for resin used as a bonding material. If the concrete section had no significant damage, the steel elements could be placed directly without any preparation. Otherwise, the integrity of the damaged element had to be restored prior to the construction of the steel jacket. After the jacket was completed, the steel elements were protected against fire and corrosion, by applying a concrete mortar or grout.

Columns

The use of steel angles on each column corner attached to welded plates or bars was a common procedure for jacketing columns with steel elements (Fig. 4.7). In some cases, the steel plates were preheated before welding to increase confinement of the steel angles after cooling. The plates were welded horizontally at equal spacings along the column height or diagonally forming a vertical truss. The voids between the steel elements and the concrete columns were filled with a non-shrink mortar or grout to insure uniform confinement.

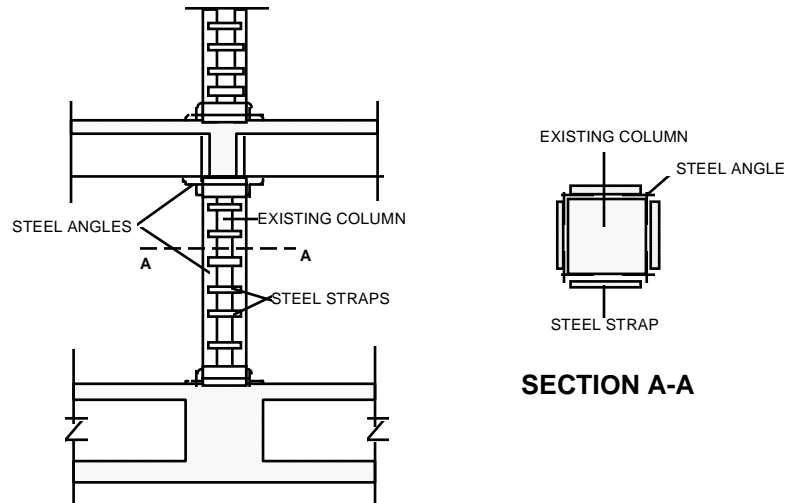

Figure 4.7 Column steel jacking.

The steel elements on the column were connected through the slab using a steel collar surrounding the column. If the column was in compression, the forces were transferred through the collar directly. If the sections were in tension, bolts could be installed through the slab to provide continuity. The collar distributed stresses at the slab-column connection to avoid slab punching shear problems.

Because of the problems associated in making the steel elements continuous through the floor system, this repair procedure is reliable only for increasing the shear and axial capacity of the column, without increasing its flexural or tensile strength. It has been reported that a significant increase in ductility can also be attained provided the elements confine the section adequately and the steel straps delay concrete crushing [Sugano 1983].

Beams and Slabs

Steel plates or straps were used to enhance the shear and flexural strength of slabs and beams. Steel elements were bonded to the concrete surface with the use of resins. Epoxy grouted dowels were used to attach the steel elements to the existing concrete surface. If the plates were added on the bottom face of the beam, flexural capacity was enhanced, whereas the attachment of plates or straps on the sides was intended to improve shear strength (Fig. 4.8).

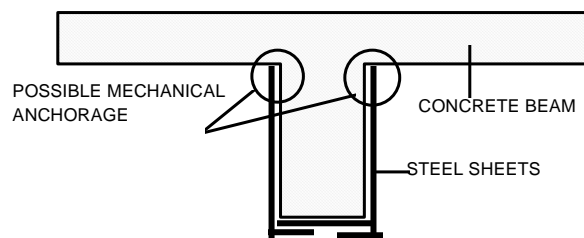

Figure 4.8 Beam steel jacking

Another way in which beams were strengthened with steel elements was with the use of externally post-tensioned ties. Threaded U-shaped rods were used to provide confinement and added shear strength to the repaired beam. Angles were added between the ties and the beam corners to avoid stress concentrations due to post-tensioning. The tension force was applied by tightening the rods to the beam surface with nuts tightened from the top of the slab (Fig. 4.9)

Increase in Wall and Slab Sections

In many structures, material was added to increase the thickness of wall and slab elements that were damaged or that had inadequate strength for design lateral loads.

Damaged walls were restored and upgraded with the addition of a new layer of reinforced concrete added to one or two sides of the wall. An increase in thickness enhanced the shear capacity of the wall (Fig. 4.10A). Better behavior was expected if material was placed on both sides of the wall and connected by ties or dowels to improve transverse restraint. The use of shotcrete was recommended because of its ease in construction, but cast in place concrete was also used. For an increase in the flexural capacity, new material especially steel reinforcement was placed at the boundary elements (Fig. 4.10B). The longitudinal reinforcement in the elements had to be made continuous through the floor system to improve the flexural performance of the wall. Shear and flexural capacities were enhanced by increasing the overall thickness of the wall as shown in Figure 4.10C.

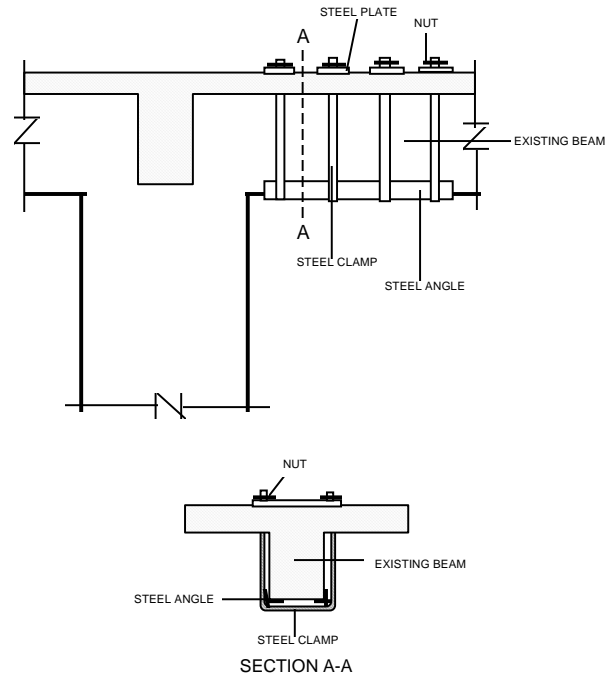

Figure 4.9 Added beam ties.

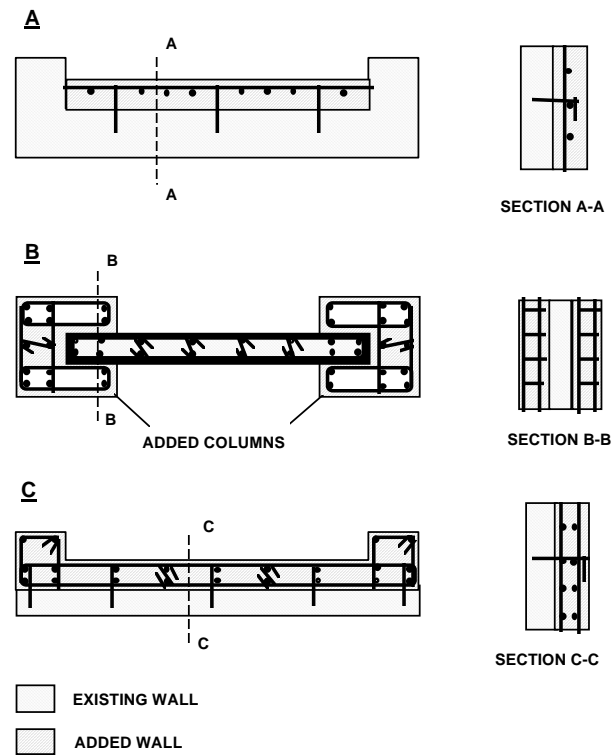

Figure 4.10 Wall increase in section.

To obtain monolithic behavior, the existing material surface was prepared prior to the addition of the new concrete section. Adequate shear transfer was achieved by roughening the old concrete surface and using epoxy grouted dowels embedded in the concrete interface. The wall reinforcement was made continuous over the height of the building to insure proper wall behavior. Holes were bored into the slab to allow continuity of longitudinal reinforcement, improve the force transfer between the wall and the slab, and allow better concrete compaction near the wall-slab interface.

Results from tests conducted on repaired walls using this procedure suggest that the strength and stiffness of the wall can be as high as an undamaged monolithic wall if the shear transfer mechanism provided is adequate [Teran 1988].

The addition of a new layer of reinforced concrete was also used to repair damaged or undamaged slabs with insufficient strength and stiffness to distribute the lateral forces to the resisting elements. Reinforced concrete was added to the top or bottom surfaces of the slab as shown in Fig. 4.11. Cast in place concrete was used for the top surface whereas the use of shotcrete was suggested if the material was added on the bottom surface. Shear transfer elements (grouted dowels) were provided to insure monolithic behavior.

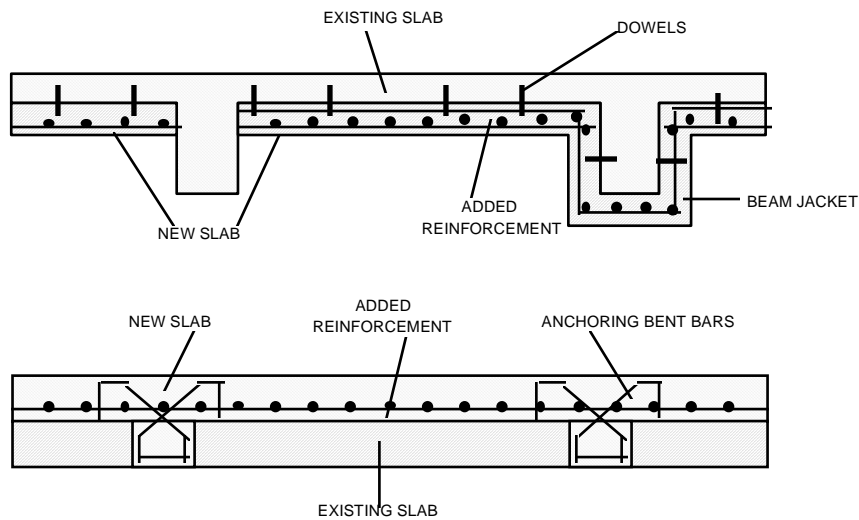

Figure 4.11 Slab section increase.

Post-tensioning

External stressing was used to repair elements with insufficient capacity or with extensive cracking or large deflections (Fig. 4.12). The reactions created in the anchoring devices had to be carefully evaluated to avoid damaging the existing element. Also, a thorough analysis of the cable position was made to control the effects of post-tensioning (eccentricities and secondary moments).

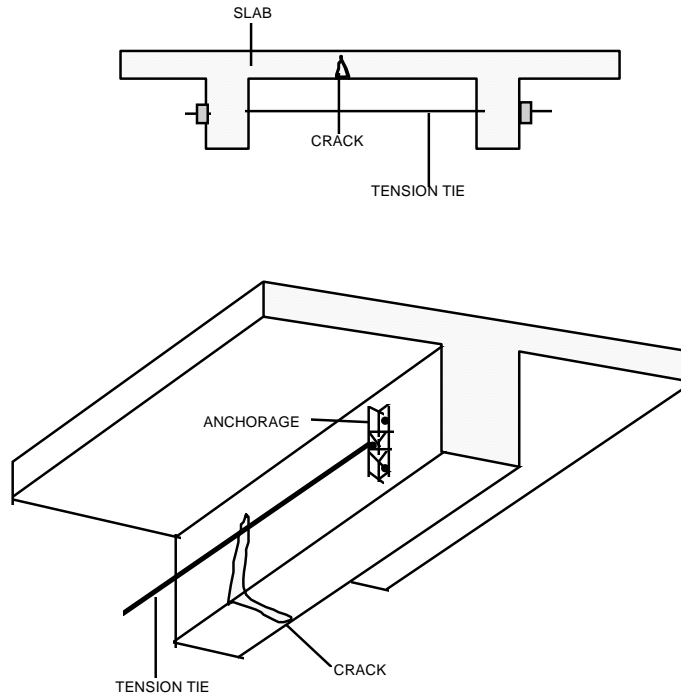

Figure 4.12 Post-tensioning technique.

4.3.2 Change of Lateral Force Resisting System

The techniques described in this section required detailed analysis of the structural behavior before and after rehabilitation. An increase in the lateral capacity of the structure is obtained with the addition of new lateral force resisting elements. To accomplish this, the original load paths have to be changed and a careful evaluation of the force distribution is needed to avoid damage to existing elements.

The design of the new elements had to take the deformational characteristics of the existing structure into account. The existing elements must be able to deform without failure when lateral forces are induced in the repaired structure if the scheme is to function successfully. Connection details between the new elements and the original structure were designed and constructed to achieve proper force transfer for the new elements to be fully effective. The forces introduced to the existing foundation by the new elements had to be evaluated carefully to determine if foundation strengthening was needed. In some cases, new foundations or additional foundation elements had to be constructed to support the forces created by new lateral force system. The horizontal floor diaphragm had to be connected effectively to the new elements for the transmission of lateral forces to be accomplished. In some cases, the slabs had to be strengthened to be able to distribute the new lateral force demands.

The selection of the techniques available depends on the damage and deficiencies of the original structure. The use of concrete structural walls, steel and

cable bracing, concrete frames, and masonry or concrete infill walls are discussed in the following sections.

Concrete Structural Walls

The use of concrete shear walls was the most common technique used to eliminate stiffness eccentricities in a building or to increase lateral load carrying capacity. The most attractive solution was obtained by locating the structural walls in the perimeter of the structure therefore reducing interior interference (Fig. 4.13). Cast in place concrete or shotcrete were generally used. The use of precast concrete panels was limited because of connection difficulties between the panels and slab.

If the walls were located in the building perimeter frames, the connections to the slab were sometimes accomplished by adding new concrete elements as shown in Figure 4.14 [Iglesias, et al. 1988]. Longitudinal and transverse reinforcement in the wall was made continuous throughout the height of the building. If there were beams in the perimeter frames, the walls had to be offset to pass the longitudinal reinforcement. Eccentricities created on the columns had to be evaluated and in general, the columns were strengthened for better behavior.

Enough transverse reinforcement had to be provided at the base of the wall to improve ductility. Recommendations were made to attach the structural wall to existing columns whenever possible so that gravity forces would reduce the uplift generated at the ends of the wall due to overturning moments as lateral loads were applied.

Figure 4.13 Addition of shear walls

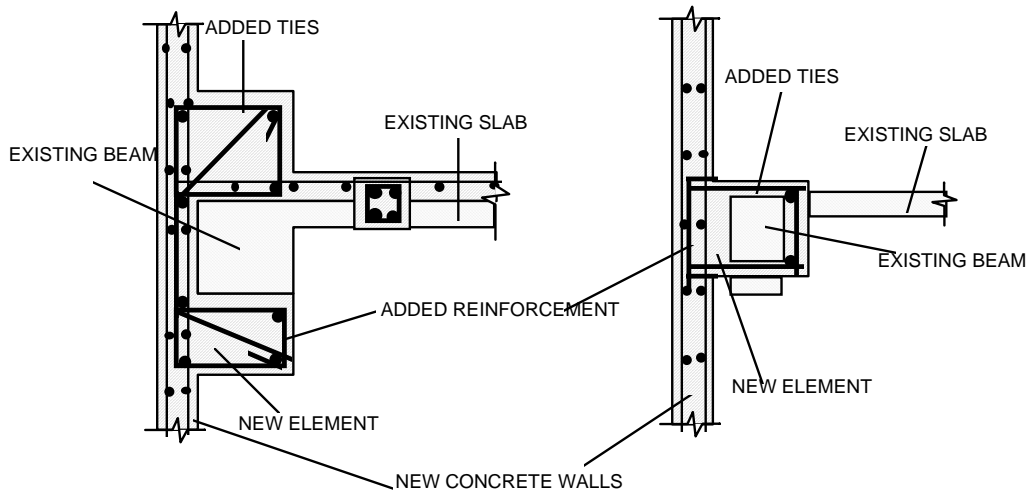

Figure 4.14 Section through floor showing connection of new concrete wall to existing slab.

Steel Bracing

Space and lighting limitations in a structure may make it desirable to use steel bracing instead of concrete structural walls. In addition, steel bracing may be more easily and rapidly installed. Exceptional results have been obtained with the use of steel elements forming vertical trusses for the repair of earthquake damaged structures in Mexico City [Del Valle 1980]. In some cases, slabs had to be strengthened locally to transmit lateral forces to bracing elements.

The main problem that had to be addressed when using this technique was anchorage of steel elements to the existing concrete structure. Tests have been conducted to assess the influence of different parameters on the behavior of steel sections connected to a concrete element with epoxy bonded bolts [Wiener 1986]. The best results in the experimental tests were obtained when epoxy was used to improve bond between the two materials. The excess resin filled the void between the bolts and the drilled holes in the steel section, distributing bearing stresses of the bolts against the steel section more uniformly. This was done in most of the buildings rehabilitated with steel bracing in Mexico City.

Welded connections were also used to attach steel braces to the existing concrete elements. In this case, collars or steel jackets surrounded the columns. Welding against steel column jackets provided a very good alternative because the axial forces generated by the steel braces can be carried by the strengthened columns.

In other cases, steel elements located in the perimeter frames were fixed at the floor levels to the exterior face of the columns. This was done by anchoring the steel brace elements to a steel plate with bolts. The plate was bonded to the concrete

surface with epoxy grout and post-tensioned rods were used to anchor it to the beams (Fig. 4.15). Shear keys were sometimes provided to enhance force transfer [Del Valle 1980].

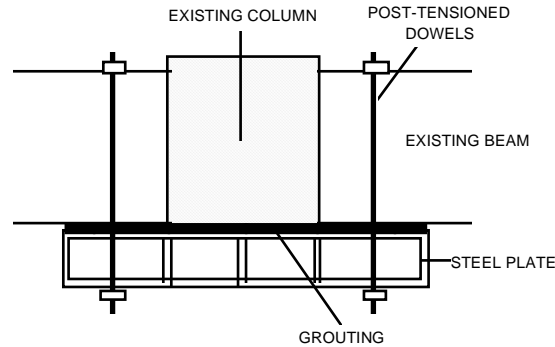

Figure 4.15 Attachment of plate to exterior frame.

The bracing configuration chosen and the assembly techniques used were dependent on operational and dimensional variability of the structure. It was suggested that field measurements of the existing structure be determined before fabricating the steel elements, as actual dimensions generally differ from the dimensions indicated in drawings.

Infill braces were used when the existing beams and columns have adequate shear capacity to resist the lateral forces induced by the braces. When the element shear capacity was insufficient, the elements had to be strengthened or an interior steel frame provided to transfer the force between the brace and the floor system [Teran 1988].

Experimental research suggests that to achieve ductile performance of the repaired structure, inelastic buckling of the steel elements has to be avoided. The use of low slenderness ratios in the design of the bracing elements has been recommended to make the elements yield in compression rather than buckling [Badoux et al. 1987]. It has also been reported in the literature that large displacements at the connections are associated with inelastic buckling and this could trigger connection failures. Buckling also limits inelastic energy dissipation of the bracing system. To achieve adequate performance of the bracing system, the deformational characteristics of the concrete structure and the braces have to be matched such that the ultimate capacities of the two systems are reached almost simultaneously. The bracing system could be designed to behave elastically which, in addition of eliminating buckling, would limit drift during an earthquake [Badoux et al. 1987]. Many rehabilitation steel bracing systems in Mexico City used steel elements with high slenderness ratios.

Cable Bracing

Tension braces or cables were used to eliminate the problems associated with inelastic buckling of bracing systems. These systems are known to buckle elastically under load reversals, and the application of a prestressing tensile force can improve the behavior of the system under service conditions. With this technique, an increase in stiffness of the original structure was obtained. Also, the repaired structure can be expected to behave elastically in a wider range. However, care should be taken to avoid creating a structure that would go into resonance with the incoming ground motion since there is no energy dissipation through elastic behavior.

Cable braces were used effectively to upgrade undamaged low to medium rise school buildings in Mexico City that had to be redesigned for the higher level of forces specified by the codes. The cable system and the existing structure had to interact to achieve acceptable structural response. The original structural stiffness is important to determine the lateral load that is transmitted to the cables. The axial loads generated by the cables in the columns of the original building have to be considered. Columns could be strengthened by one of the techniques described previously where necessary.

Concrete Frames

Another repair alternative that was selected where space and lighting limitations existed was the use of reinforced concrete frames added to the original structure. Foundation strengthening of the existing structure was often associated with the implementation of this solution because of an increase in dead load. Economic and construction issues were very important when this technique was used.

The construction of frames is practically limited to the perimeter of the building because of the problems inherent in connecting the new system to the original structure. Connections were performed in a similar way as those described for reinforced concrete structural walls. Effective connections to the floor diaphragms were designed for adequate transfer of lateral forces to the new concrete frames.

Infill Walls

Masonry or reinforced concrete infill walls were sometimes added to the interior bents of reinforced concrete frames. The use of infill walls has been shown to control effectively lateral displacements. Infill wall behavior is similar to structural wall behavior as long as continuity is provided with the framing elements (existing beams and columns). In this case, the columns acted as boundary elements (Fig. 4.16). These walls significantly increased the lateral strength of the existing frame.

In Mexico City, concrete infill walls were normally cast in place or shotcreted. Epoxy grouted dowels embedded into the original frame, usually at 10 in., were used to anchor the walls effectively to the existing frame. Column axial capacity had to be sufficient to resist tensile and compressive forces induced at the boundaries of the structural wall. If the column shear strength was not adequate to resist the shear forces, the wall was not anchored to the columns and anchored only to the beams (Fig. 4.17B). No gap was provided between the wall and the columns. Ductile behavior can be obtained in this case if a space is left between the infill wall and columns. If infill walls were used in combination with complete concrete jacketing of beams and columns, wall reinforcement could be anchored effectively to the reinforcement in the element jackets. Otherwise, the recommendations for shear transfer, regarding surface preparation and dowel installation, had to be followed.

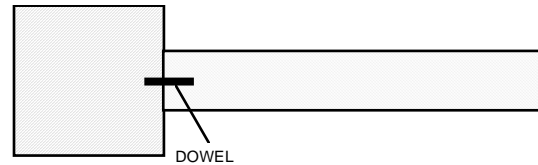

A) ADEQUATELY REINFORCED COLUMN

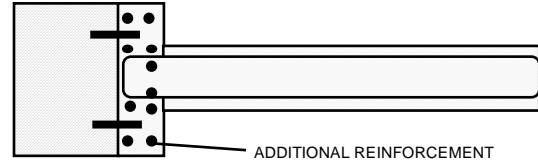

B) LONGITUDINAL REINFORCEMENT ADDED

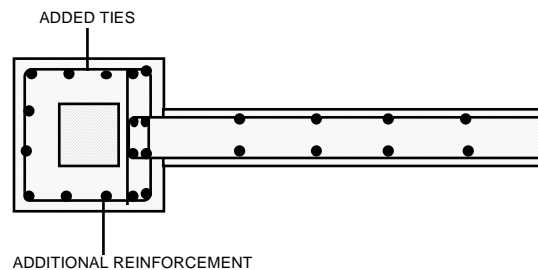

C) COLUMN JACKET ADDED

Figure 4.16 Infill wall connection.

Masonry elements were also used to build infill walls when the expected shear forces were not very large. A reinforced shotcrete jacket on both sides of the wall was suggested in some cases since it was expected to enhance ductile behavior

4.3.3 Special Techniques

The techniques presented in this section were generally performed in combination with other types of rehabilitating schemes when large amounts of damage had been experienced by the structure or when the structure had been greatly modified to significantly change its original load paths. The cost associated with the implementation of these techniques is considerably higher than that associated with the techniques described previously. Space within the building might significantly be reduced and a careful evaluation of the socio-economic implications had to be considered before proceeding to rehabilitate these structures.

Floor Removal

Floor removal was used when a significant reduction of inertia forces was required. The technique was used in buildings which suffered severe upper floor damage or collapse after the earthquakes in Mexico City. The reduction in weight leads to a reduction in structural base shear. The force demands on the building foundation were decreased with this technique, which was useful for the case of Mexico City because of the difficult subsoil conditions encountered.

Foundation Strengthening

When load paths are changed in a structure, the way forces are transmitted to the foundation also changes. Also, the addition of stiff elements to an existing structure will generate higher forces at the foundation level

which have to be transferred into the supporting soil for the repair to be effective. In these cases, strengthening of foundations was required. In some instances, new foundations had to be constructed for the new lateral force resisting systems (walls and braces). Axial loads on the foundations increased due to the generation of large base overturning moments. The most common procedure used to resist the forces generated by the new elements was the addition of piles. Piles were sometimes driven in sections due to space limitations in the foundation basement. If pile groups were used to support the load coming from a single column, the pile caps had to be strengthened locally to distribute the load uniformly to all the piles in the group (new and existing piles).

In some cases, foundation beams were added to tie isolated footings or pile caps together. Proper anchorage between the grade beams and the isolated elements was provided to insure continuity.

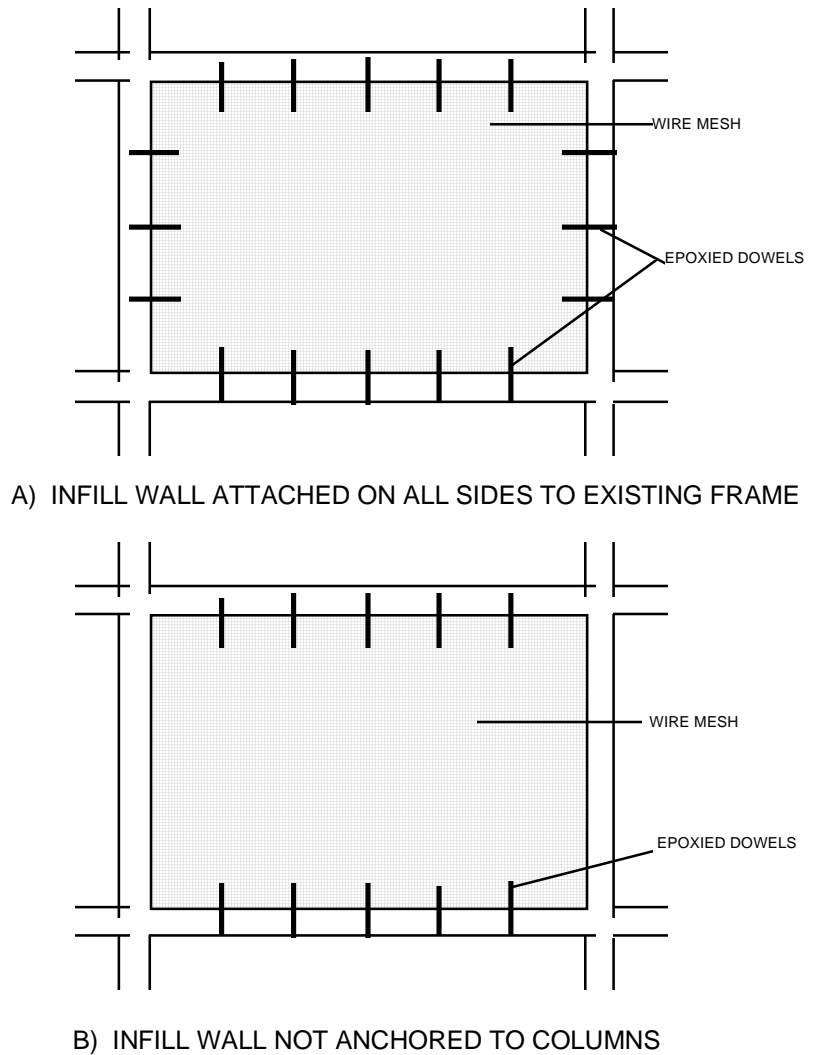

Figure 4.17 Infill wall connections.

Control piles (see Section 2.2.1) have been used in Mexico City to rehabilitate tilted structures. Differential settlements in the structure can be controlled by devices located at the pile head. These elements carry a pre-determined load and therefore control the force that goes into the pile. The piles located in a section of the building which has suffered considerable settlement can be unloaded until other sections of the building experience the same amount of settlement. In this way, the building settles uniformly as the underlying soil consolidates.

4.4 VERIFICATION OF THE PERFORMANCE OF REHABILITATED STRUCTURES

In several rehabilitated buildings the effectiveness of the retrofitting scheme was verified by comparing the fundamental period before and after the repair. The measuring of fundamental periods was done by means of vibration tests using the structural excitation produced by the ambient vibrations (circulating traffic). At this time, only a few buildings have permanent seismic instrumentation.

5.4 BUILDING D

Building Description

The four story, reinforced concrete building houses classrooms and laboratories. It is located in the southeast part of the lake bed zone of Mexico City. In one direction, the building consists of 15 bays, with a total length of 101 m. In the short direction, there is one 8.00 m. bay and a 3.75 m. cantilever. A typical building plan and elevation are shown in Figure 5.D1.

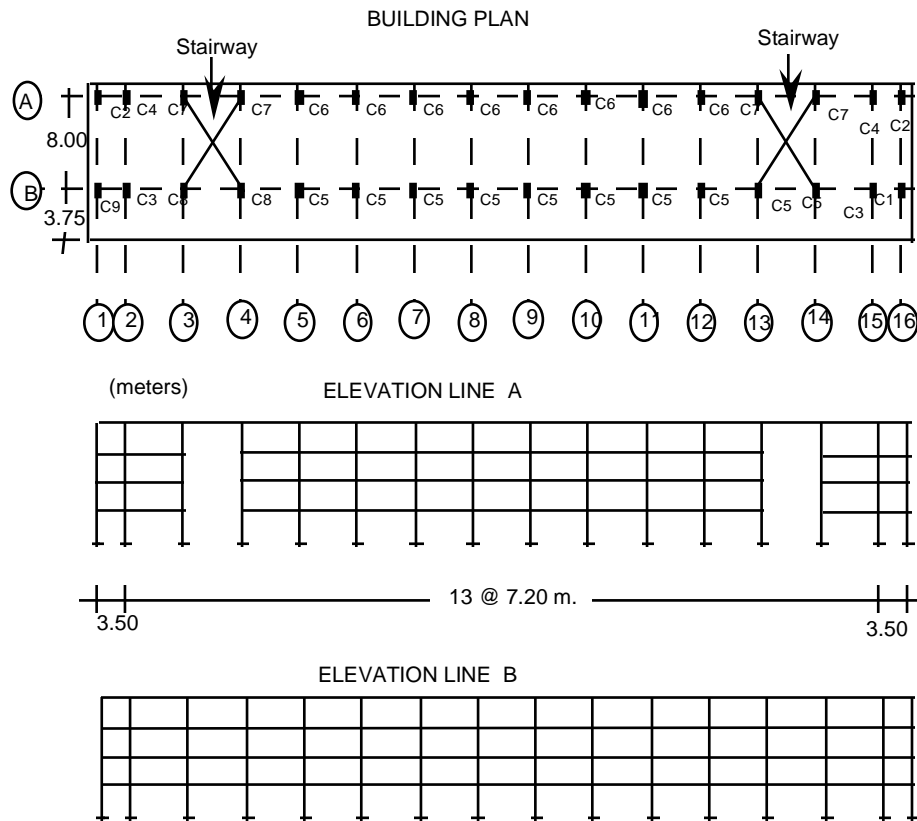

Figure 5.D1 Building plan and elevation.

The floor system is a reinforced concrete waffle slab supported on concrete columns that have a rectangular cross section. A column schedule is shown in Fig. 5.D2 and column details are listed in Table 5.D1. The design material strengths were as follows:

Concrete strength	$f'c = 250 \text{ Kg/cm}^2$
Steel reinforcement	$f_y = 4200 \text{ Kg/cm}^2$

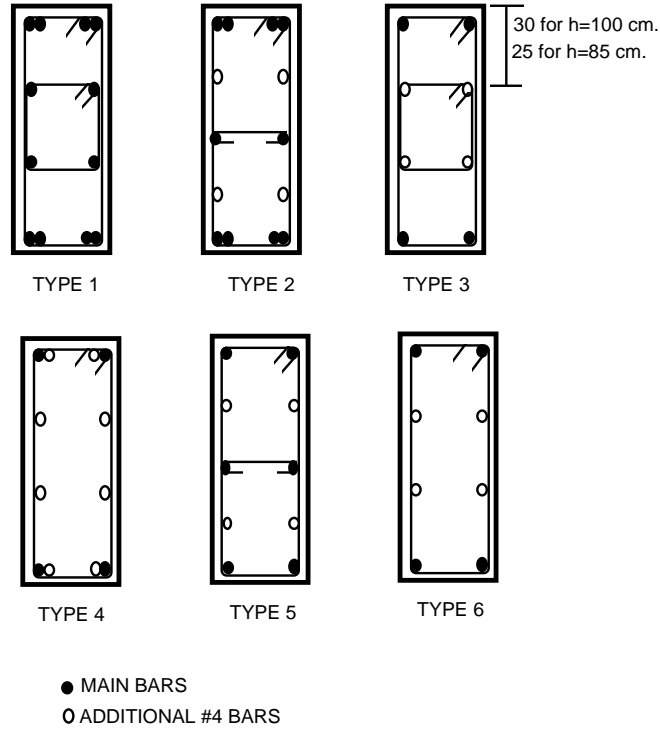

Figure 5.D2 Column cross sections (see Table 5.D1).

STORIES	FOUNDATION TO STORY 2			STORY 2 TO ROOF		
	COLUMN	SECTION cm.	MAIN BARS	HOOPS	SECTION cm.	BARS
C1	25 X 100 TYPE 1	12 # 10	2#3 @ 25	25 X 100 TYPE 2	10 # 10	1#3 @ 25 1#2.5@25
C2	25 X 85 TYPE 3	8 # 10	2#3 @ 30	25 X 85 TYPE 6	4 # 10	1#3 @ 30
C3	35 X 100 TYPE 4	8 # 10	1#3 @ 25	35 X 100 TYPE 4	4 #10 4 # 6	1#3 @ 30
C4	35 X 85 TYPE 4	8 # 10	1#3 @ 25	35 X 85 TYPE 4	4 #10 4 # 6	1#3 @ 30
C5	35 X 100 TYPE 4	8 # 10	1#3 @ 25	35 X 100 TYPE 4	4 #10 4 # 6	1#3 @ 30
C6	35 X 100 TYPE 4	4 # 6 4 # 10	1#3 @ 30	35 X 100 TYPE 4	4 #10 4 # 6	1#3 @ 30
C7	35 X 100 TYPE 1	4 # 10 8 # 6	1#3 @ 30 1#2.5 @ 30	35 X 100 TYPE 3	4 #10 4 # 6	1#3 @ 30 1#2.5 @ 30
C8	35 X 100 TYPE 1	12 # 10	2#3 @ 25	35 X 100 TYPE 3	8 # 10	1#3 @ 30
C9	25 X 100 TYPE 2	10 # 10	1#3 @ 25 1#2.5 @ 25	25 X 100 TYPE 5	6 # 10	1#3 @ 30 1#2.5 @ 30

Table 5.D1 Column reinforcement.

The building rests on a partially compensated foundation box. The foundation box is approximately 4.00 m. deep.

The partition walls in the restroom and stairway areas of the building are made of solid clay brick. The rest of the interior partition walls are made of hollow clay brick reinforced with #3 bars at every intersection or edge, or spaced at a maximum of 1.20 m. (Fig. 5.D3). All the partition walls were intended to be isolated from the lateral force resisting system by a 1 cm gap, but in practice the solution was not sufficient and there was interaction with columns.

There are two reinforced concrete walls located at the edge column lines (column lines 1 and 16) running in the short direction (curtain walls).

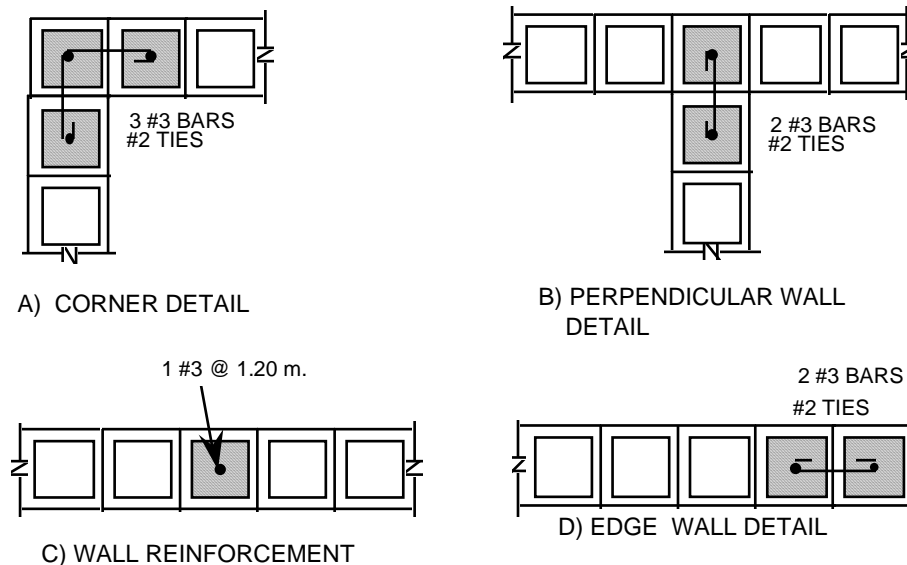

Figure 5.D3 Wall reinforcement arrangements.

Description of Damage After the 1985 Earthquake

The arrangement of partition walls in stairway zones produced short columns in line A. The 1985 earthquake produced cracks (>1mm) in columns around stairway areas, particularly captive columns in line A. School buildings with similar structural systems constructed on transition soil zone adjoining the lake bed in Mexico City had lighter damage at the same locations in the structure.

The building was retrofitted not only because of the damage that occurred but because the new seismic regulations in the Mexico City Code required Group A structures to be upgraded to resist the higher design forces specified in the code (school buildings are included in Group A).

Strengthening Procedure

The structure was retrofitted using a cable bracing system in the longitudinal direction along column lines A and B. Several bracing configurations were analyzed in order to obtain a bracing system in which the braces and the original structure would reach their capacities at approximately the same displacement level. The configuration selected is shown in Figures 5.D4 and 5.D5. The bracing consisted of 1/2" diameter cables, post-tensioned only at 10% of their capacity to prevent sagging. The details of the cables passing through a slab-column joint can be seen in Figures 5.D6 to 5.D8. The solution was viable because of the way in which the main longitudinal reinforcement was arranged in the columns. Since the original structure consisted of a waffle slab, no beams were found at the joints. However, to drill the cable ducts through the joints was a difficult task in the construction procedure.

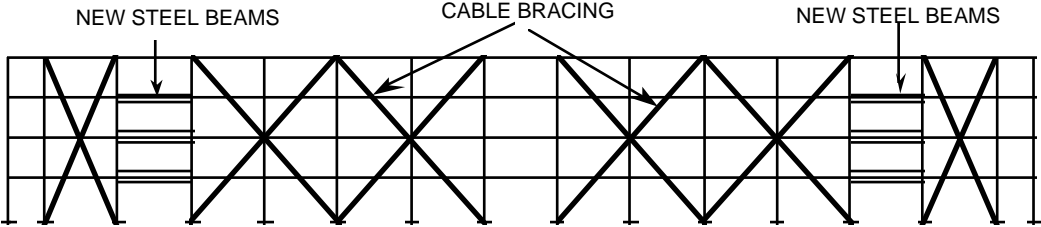
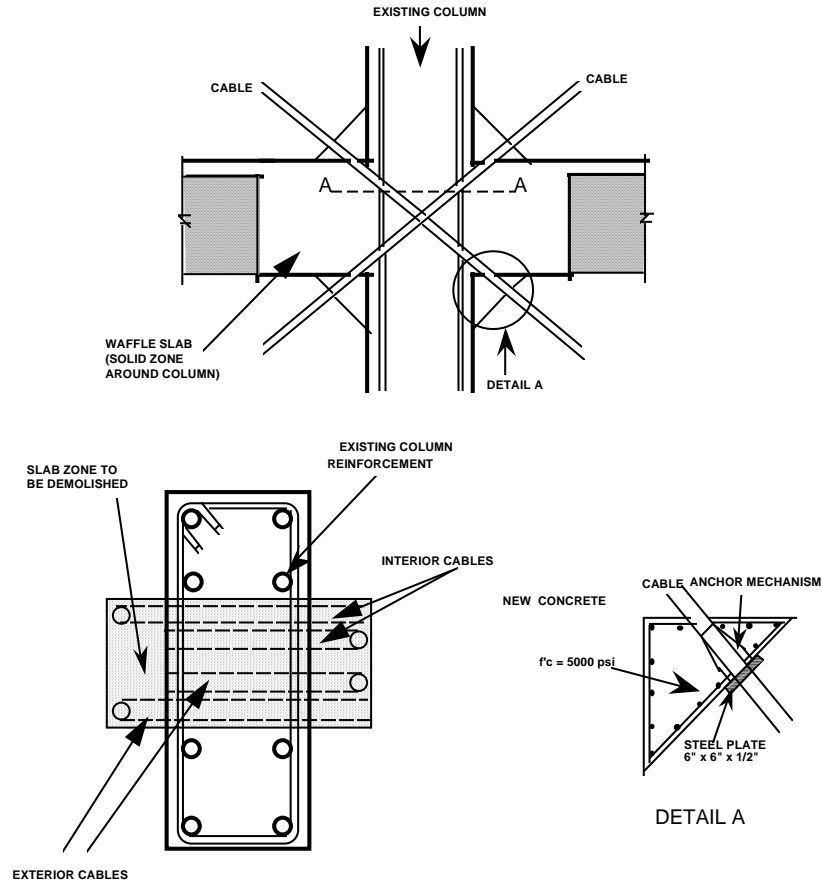

Figure 5.D4 Bracing system.

Figure 5.D5 Cable brace in line A.



SECTION A-A

Figure 5.D6 Slab-column joint.

Figure 5.D7 Exterior view of joints.

Figure 5.D8 Cables through slab-column joint.

Because the waffle slab was interrupted in the bays that correspond to the stairway areas (between lines 3 and 4; and between lines 13 and 14. See Figure 5.D1), steel beams were provided for continuity between the bays bordering the stairway area (Fig. 5.D9). Steel beams were added to reduce the structural discontinuity in the stairway areas where column damage was concentrated.

Figure 5.D9 Steel beams in stairway.

Since the vertical component of the cables induced large axial loads on the columns, the columns were strengthened to resist the added load. In the first story the columns were upgraded with steel angles located at the column corners. Columns in lines 2,3,4,13,14 and 15 also were strengthened in the second and third stories with steel plates added to the long column as shown in Figure 5.D10.

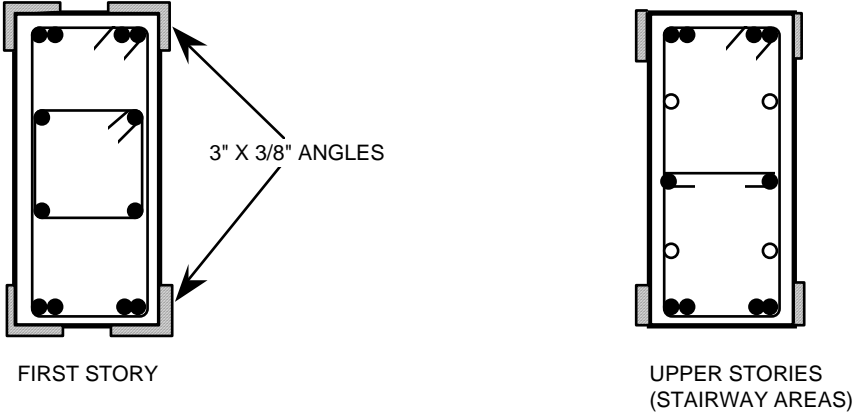

Figure 5.D10 Column strengthening.

To increase the lateral strength in the short direction of the building, the infill masonry walls in the stairway areas (lines 3,4, 14 and 15) were strengthened with wire mesh and shotcrete on both sides.

According to the design calculations an increase in stiffness of 80% over that of the original structure was expected. The linear elastic range and the strength of the structure were also expected to increase significantly.

The north facade of the strengthened building is shown in Figure 5.D11.

Figure 5.D11 Strengthened building.

5.5 BUILDING E

Building Description

The building is located in the lake bed zone of Mexico City. The structure was constructed in 1979 and is used as an apartment building. It has an area of approximately 215 m² per floor. The structure has a "C" shape in plan, and consists of two apartment units separated by the stairs and elevator core (Fig. 5.E1). The North unit has seven stories, and the South unit has eight stories plus a machine room (Fig. 5.E2).

At the first floor and the roof, the structure is a waffle slab supported on reinforced concrete columns. At all other levels, the slab is a beam-block floor system supported on masonry walls confined by rectangular reinforced concrete boundary elements. These walls are supported on the waffle slab and columns. As a result, the first level is a soft story. The foundation consists of a grid and slab system on friction piles.

Description of Damage After the 1985 Earthquake

Damage was concentrated in the masonry walls on all levels. The damage was worse in the E-W direction. There was no damage to the foundation, columns or slabs, and no pounding with adjacent buildings was evident. Plan, as well as vertical, irregularities and lack of lateral load bearing capacity of the masonry walls in the short direction were the principal causes of damage.

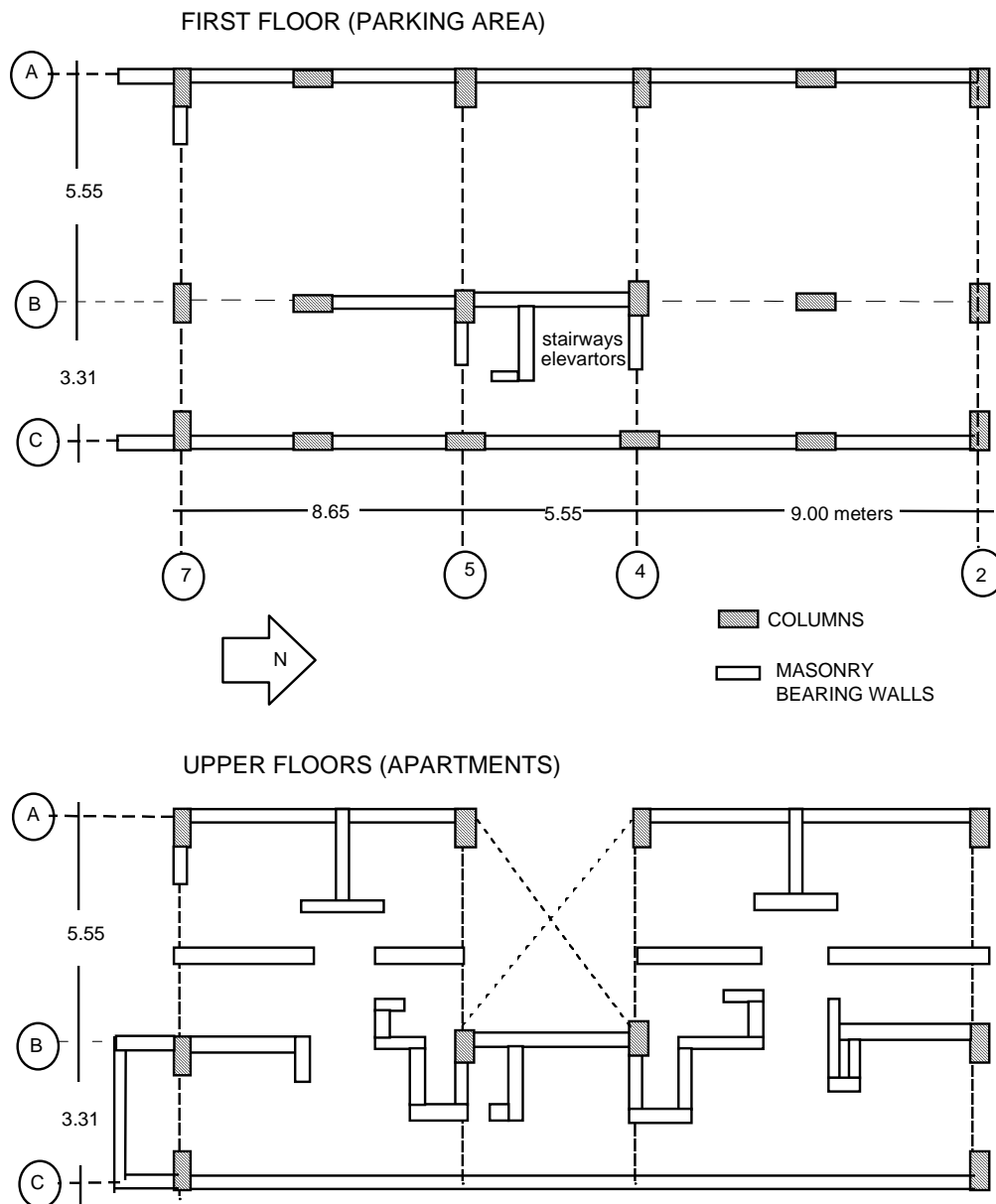

Figure 5.E1 Building plan.

Most of the E-W walls had diagonal cracks and lost plaster cover. The boundary elements of these walls also presented cracking and loss of concrete cover, with exposed reinforcement (Fig. 5.E3). Some others completely collapsed. The walls around the stairs and elevator core had severe cracking in all levels.

Figure 5.E4 shows the exterior wall on line A, which developed local failure due to the movement of the framing perpendicular wall. The rest of the walls in the N-S direction did not present any damage. This direction has considerably larger strength than the short direction, due to the massive continuous boundary walls on lines A and C (Figure 5.E1).

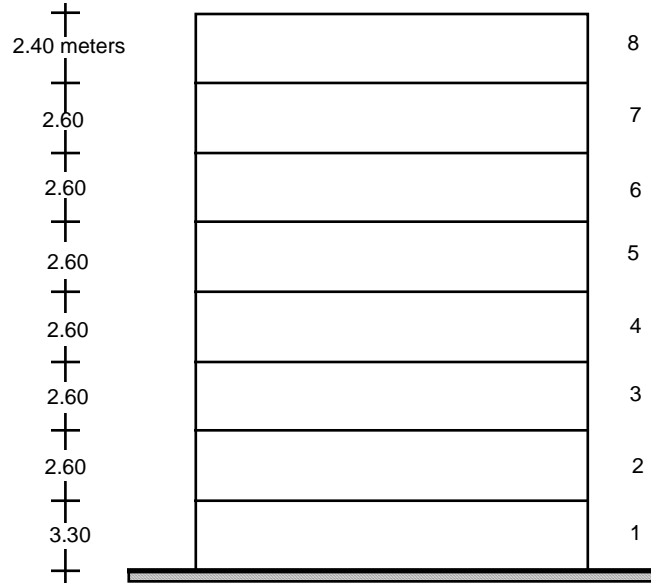

Figure 5.E2 Building elevation.

Figure 5.E3 Damage in walls.

Figure 5.E4 Damage in exterior wall on line A.

Temporary Measures

The damaged structure was shored with steel and wood elements. In the ground floor, steel frames with tubular braces were used to shore the waffle slab. Wood beams were placed at the top of the steel shores to distribute the loads to the supporting slab (Fig. 5.E5).

Figure 5.E5 Ground floor shoring.

Braced wood frames were used as shoring in upper stories. Two wood elements connected with wire formed the frames (Fig. 5.E6 and 5.E7). This bracing was placed only in the E-W direction, without any attention to their distribution in plan.

Figure 5.E6 Shoring with wood elements in upper floors.

Figure 5.E7 Shoring details.

Strengthening Procedure

To strengthen the structure in the short direction (E-W), four reinforced concrete frames were added on lines 2, 4, 5 and 7, Figure 5.E8 shows the layout of the new elements. The existing beams and columns were partially demolished then upgraded with larger sections and reinforcement.

Figure 5.E9 shows a detail of a new beam and the facade balcony which was enlarged along line 7. Pictures of the construction of the new frames are shown in Figures 5.E10 and 5.E11. A section of the floor system adjacent to the frames was also removed. The existing slab reinforcement was left in place. This reinforcement was anchored in the new concrete beams and columns, as indicated in Figures 5.E12 and 5.E13.

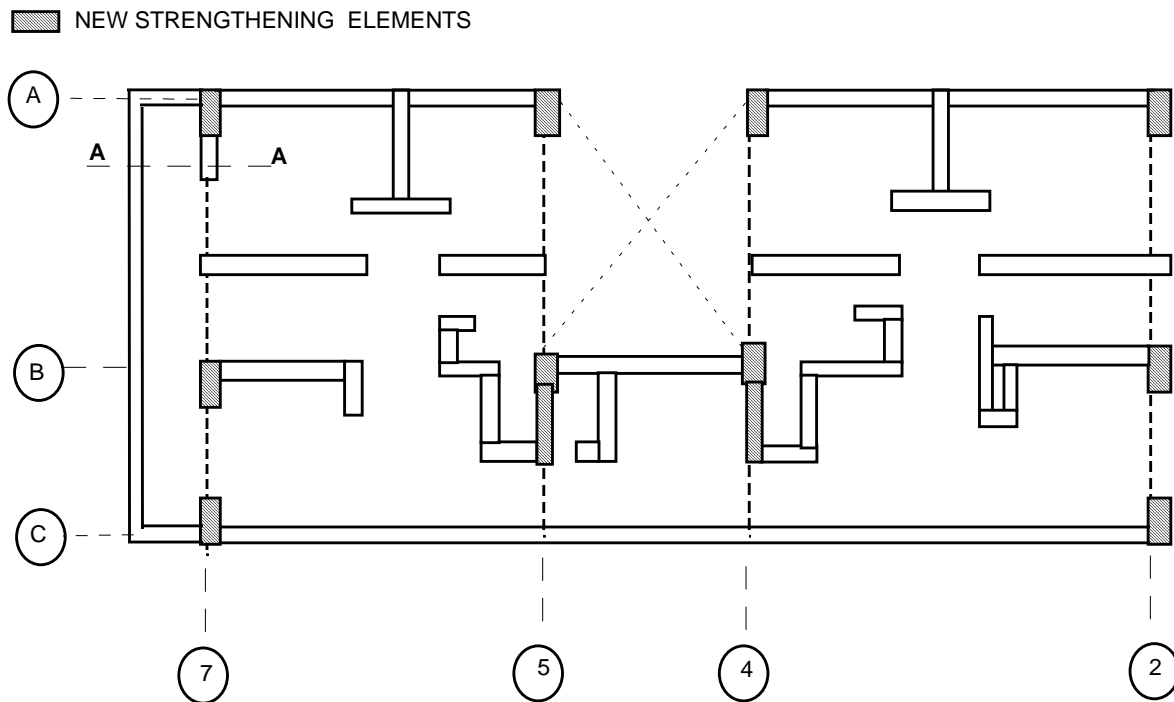
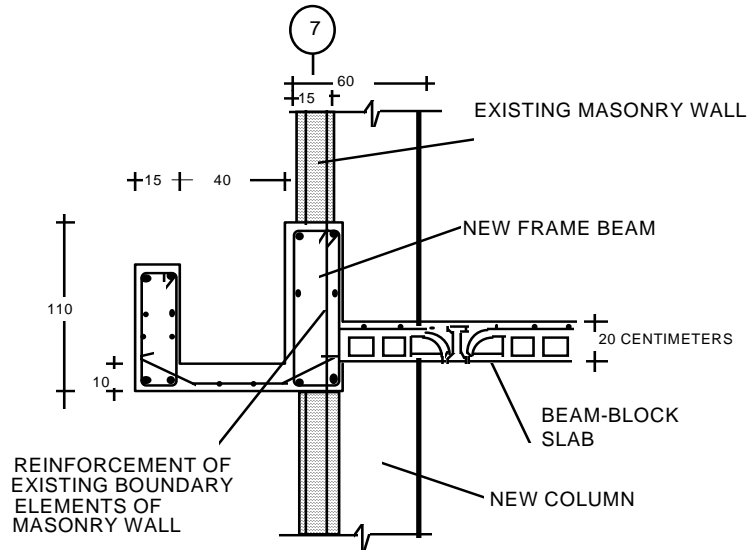

Figure 5.E8 Strengthening scheme.



SECTION A-A (From Fig. 4.53)

Figure 5.E9 Detail of new beam in frame 7.

Figure 5.E10 Exterior reinforced concrete frame.

Figure 5.E11 Detail of reinforced concrete frame.

Figure 5.E12 Connection of new reinforced concrete frame.

Two reinforced concrete walls, 15 cm thick and continuous over the height of the building, were built around the stairs and elevator area on lines 4 and 5 (Fig. 5.E14). The walls were connected to new columns B-4 and B-5 (see Fig. 5.E8). Parts of the foundation slab and foundation beams were removed to anchor the reinforcement of the new columns and walls. These details are presented in Figures 5.E15 and 5.E16. According to the design drawings, the rest of the foundation was not modified since the analysis showed it was adequate to support the new load path.

All the damaged masonry walls were repaired with wire mesh and shotcrete on both sides (Fig. 5.E17). In the N-S direction, new reinforced concrete beams were built in upper floors on boundary line A, between lines 4 and 5, to connect the two units of the original structure and reduce the torsional effects on the building. The new beams have a 20X30 cm section. These elements may act as weak coupling beams but may be insufficient to link the stiff boundary masonry walls on line A. The new beams can be seen in Figure 5.E18.

Figure 5.E13 Connection of new reinforced concrete frame.

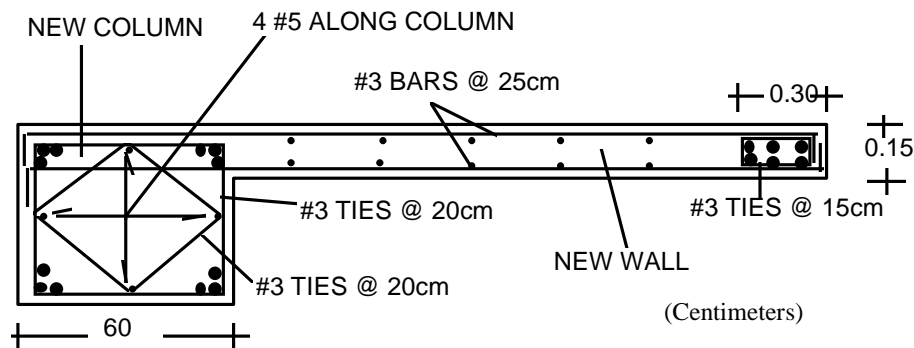
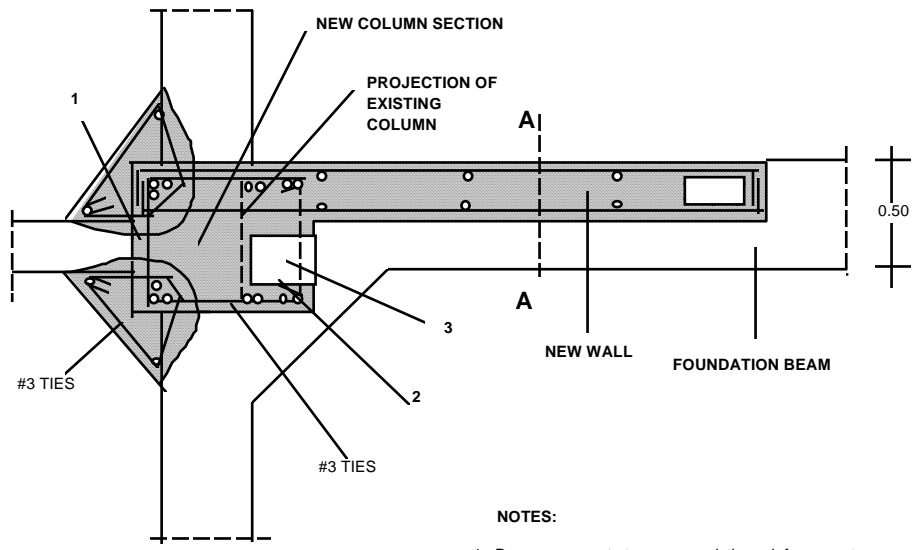

Figure 5.E14 Reinforcement details of new concrete walls.



PLAN

NOTES:

1. Remove concrete to expose existing reinforcement. Cast concrete with additive to control volume changes. Surfaces must be cleaned, roughened, free from loose particles, wet.
2. Remove column concrete cover to expose reinforcement. Casting operation must meet conditions of point 1.
3. Section of existing column to be integrated with new column.
4. Reinforcement of existing column to be integrated with new column.

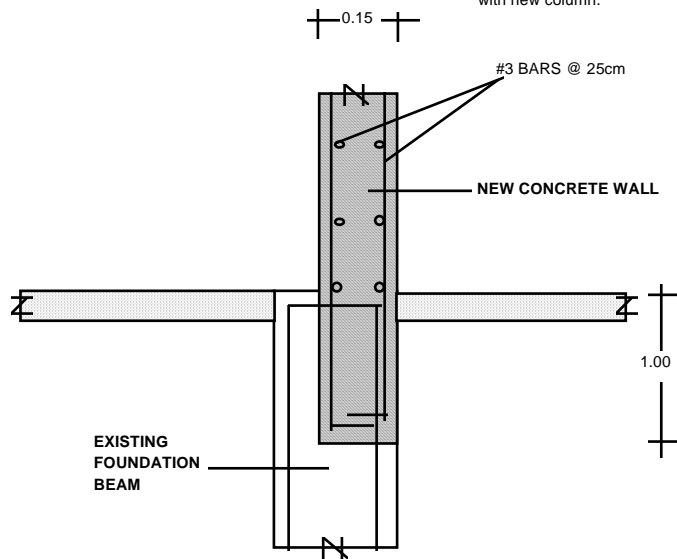

SECTION A-A

Figure 5.E15 New R/C columns and walls: anchorage to foundation.

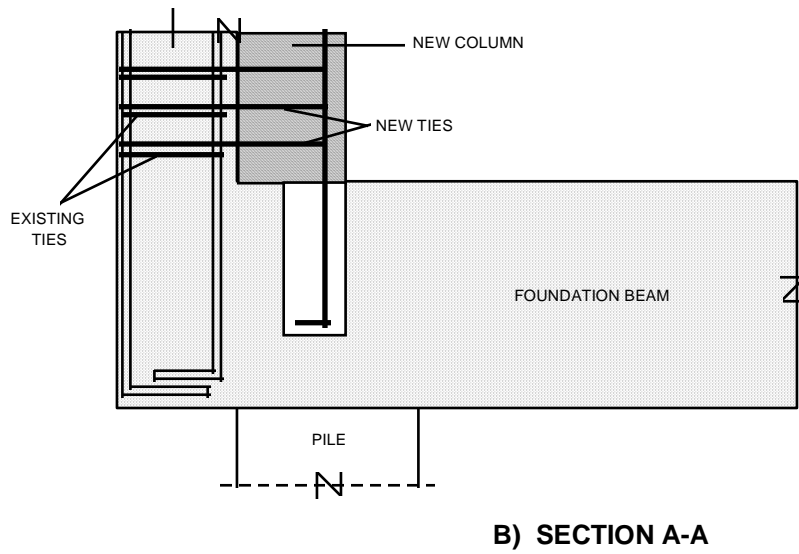
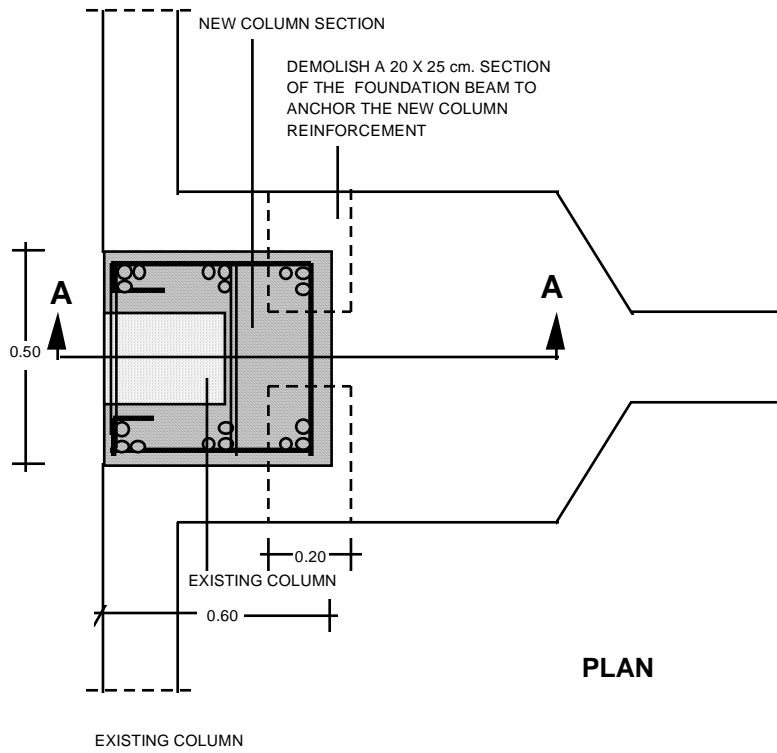
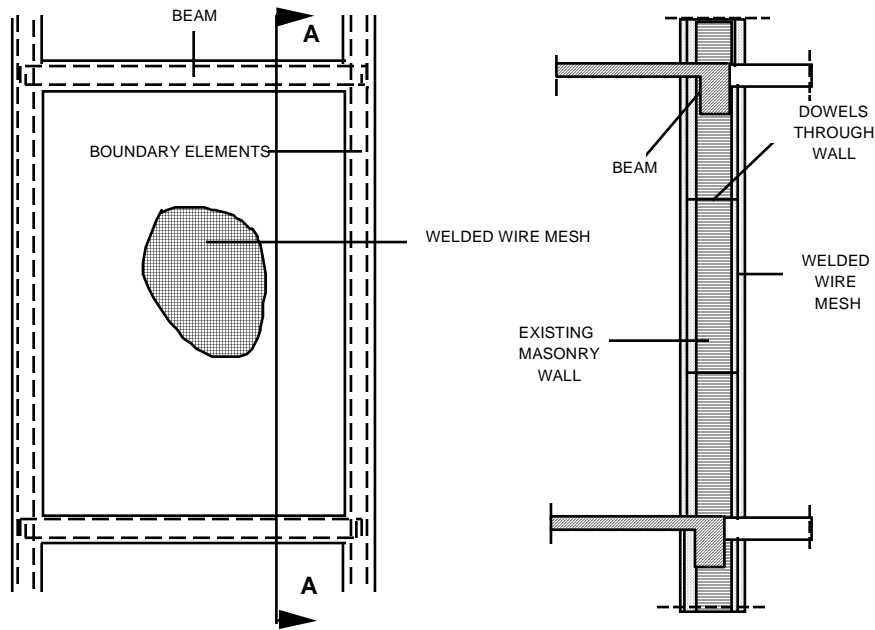

Figure 5.E16 Reinforcement and anchorage of new columns.



NOTE:
 If boundary elements confining the masonry wall are damaged, they should be demolished and replaced by new elements with the same size and reinforcement.

SECTION A-A

Figure 5.E17 Repair of damaged masonry walls.

In the design approach, the model of the retrofitted structure was analyzed assuming that only the new frames would resist the lateral forces in the short direction (E-W). For the columns with increased sections, strengths were computed assuming monolithic behavior of the new and existing elements. In this direction the ductility reduction factor was taken as $Q= 4.0$ as indicated in the 1985 Emergency Norms, which were in effect when the design was done.

A ductility factor of 4.0 was allowed when at least 50% of the lateral loads are carried by unbraced reinforced concrete frames with ductile detailing.

In the N-S direction a ductility factor $Q=3.0$ was used. However, the new 1987 Building Code assigned a factor $Q=2.0$ for structures in which the lateral strength is provided by masonry walls, as in the upper stories in the N-S direction of the building.

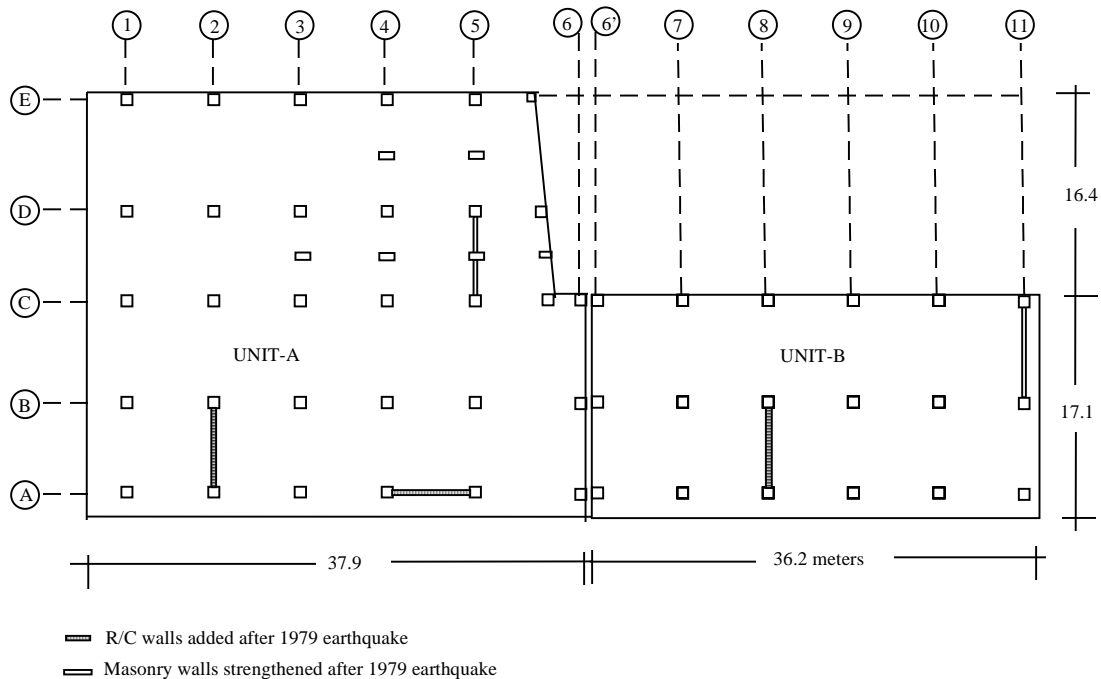

Figure 5.F1 Typical building.

5.6 BUILDING F

Building Description

The building was constructed in 1966 and is used for office and commercial purposes. The structure is divided in two independent units; unit A has a regular plan with a basement and eight floors, unit B also has a regular plan with a basement and six floors, as shown in Figures 5.F1 and 5.F2. The building has an area of approximately 1600 m² per floor.

The original structure consists of reinforced concrete frames with haunched beams. The floor system is a two way slab with beams. The foundation consists of reinforced concrete slabs and beams, with retaining walls along the perimeter that are not connected to the foundation beams.

In the 1979 earthquake the structure had some damage, mainly light cracking of structural elements. It was strengthened with the addition of three reinforced concrete walls, 15 cm thick, anchored to the existing reinforcement and their boundary columns enlarged. Also, two masonry walls were strengthened with wire mesh and a mortar layer on both faces, as noted in Figure 5.F1.

Figures 5.F3 and 5.F4 show construction details of the connection between the concrete walls, added after the 1979 earthquake, and the existing structure.

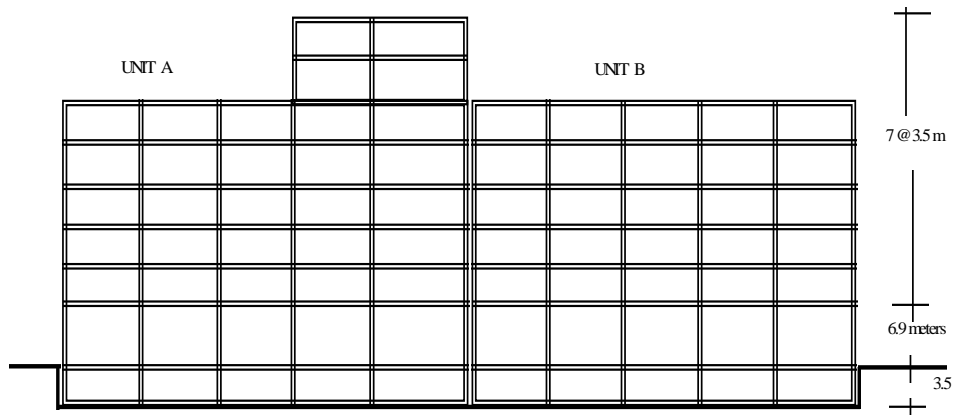
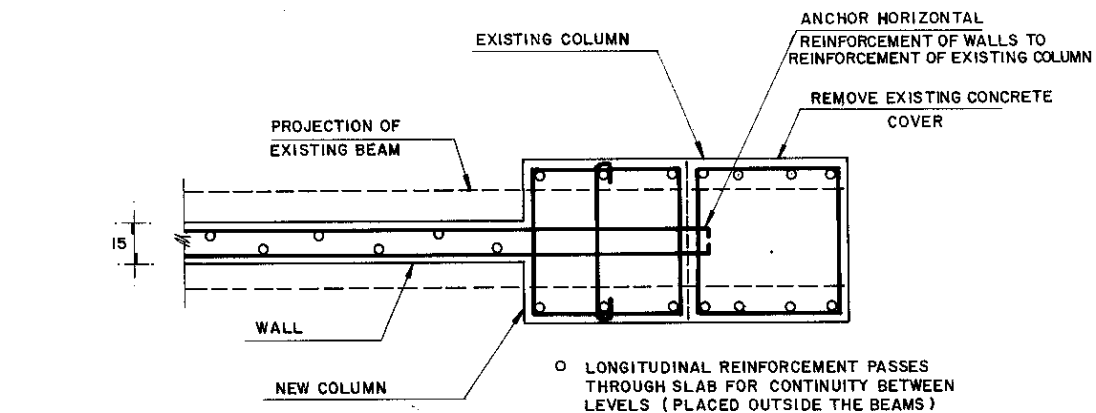
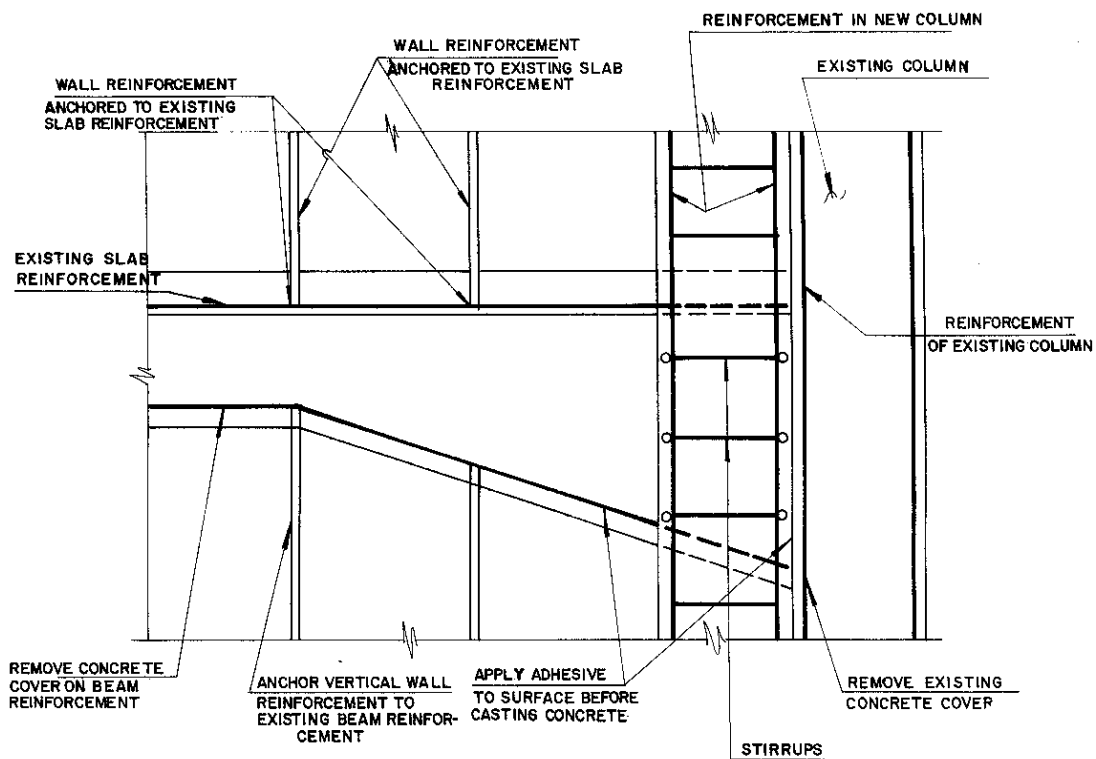

Figure 5.F2 Building elevation along line C.



P L A N



E L E V A T I O N

Figure 5.F3 Connection detail of concrete walls added after 1979 earthquake.

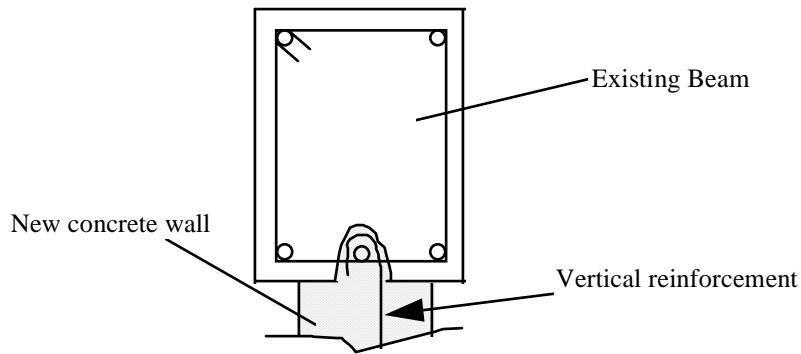

Figure 5.F4 Concrete wall anchorage detail.

Description of Damage After the 1985 Earthquake

Damage in the 1985 earthquake occurred mainly at the first level with the columns suffering the most damage. The walls added after 1979 to strengthen the structure spalled and left the steel reinforcement exposed. The intensity of damage decreased in the upper floors. There was no damage to the foundation.

In the three lower stories, the boundary columns of the walls strengthened after the 1979 earthquake had severe damage (Fig. 5.F5). The column C-5 was the most damaged and included fractured bars as shown in Figure 5.F6. Approximately 30% of the rest of the columns on these levels had crack widths of one millimeter or more. On the upper levels the number of damaged columns and the width of the cracks decreased.

The concrete walls lost material at wall-column and wall-beam connections, as shown in Figures 5.F7 and 5.F8. It was evident that the anchorage between added walls and existing elements was deficient (Fig. 5.F9). Also, poor quality materials and construction were observed in the concrete walls added after the 1979 earthquake.

On the second story, the beams on line 1, between E and D, and line 4, between C and D, lost concrete cover. The rest of the beams and slabs did not suffer any damage. Before the 1985 earthquake some of the beams had diagonal cracks, but the crack width, length and number did not increase after the earthquake.

Masonry partition walls had severe damage in the first five stories, and some collapsed. There was moderate damage to walls in upper stories.

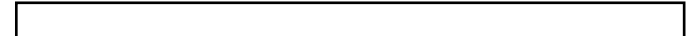

Figure 5.F5 Typical damage in boundary columns.

Figure 5.F6 Damage in column C-5.

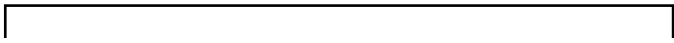

Figure 5.F7 Damage in concrete walls.

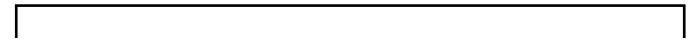

Figure 5.F8 Damage in concrete walls.



Figure 5.F9 Wall-beam anchorages.

Temporary Measures

During the repair and strengthening procedure, shoring was provided to support vertical loads. In those columns where it was necessary to replace the damaged concrete, the shoring consisted of tubular steel elements with steel base plates at ends. These elements were placed around the columns and restrained with wire ties to avoid buckling. The shoring was intended to be continuous along the height of the structure to transmit the loads directly to the foundation (Fig. 5.F10 and 5.F11). No bracing was provided for lateral forces.

The existing structure was analyzed according to the provisions of the 1985 Emergency Norms. The ductility reduction factor was taken as $Q=2$.

The observed damage and the results of the analysis were consistent.

Based on the results of the analysis of the structure and its performance during previous earthquakes, a strengthening approach was developed with the objective of

increasing the overall stiffness of the building and the strength of the columns. The strengthened structure was analyzed assuming monolithic behavior between new and existing elements.

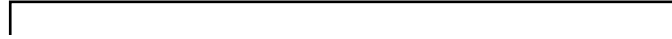

Fig. 5.F10 Shoring for vertical loads.



Fig. 5.F11 Shoring for vertical loads.

Strengthening Procedure

The strengthening approach consisted of adding reinforced concrete walls, 20 cm thick, and upgrading boundary columns with concrete jackets. Seriously damaged masonry and concrete walls were demolished and replaced by new walls. In concrete walls with moderate damage, cracks were injected with epoxy resins and their thickness was increased to 20 cm. The layout of strengthened and new concrete walls is shown in Figure 5.F12. Connections between walls and existing elements consisted of epoxy grouted dowels. Details of this procedure can be seen in Figures 5.F13 to 5.F14.

Before jacketing boundary columns with buckled bars, the damaged concrete and reinforcement were replaced. The same amount of reinforcement was provided, welded to the existing bars, and ties were added. In columns with less damage, the cracks were injected with epoxy resin.

The rest of the columns were jacketed with two layers of wire mesh and shotcrete (Fig. 5.F15 and 5.F16). Cracks were injected with epoxy resin.

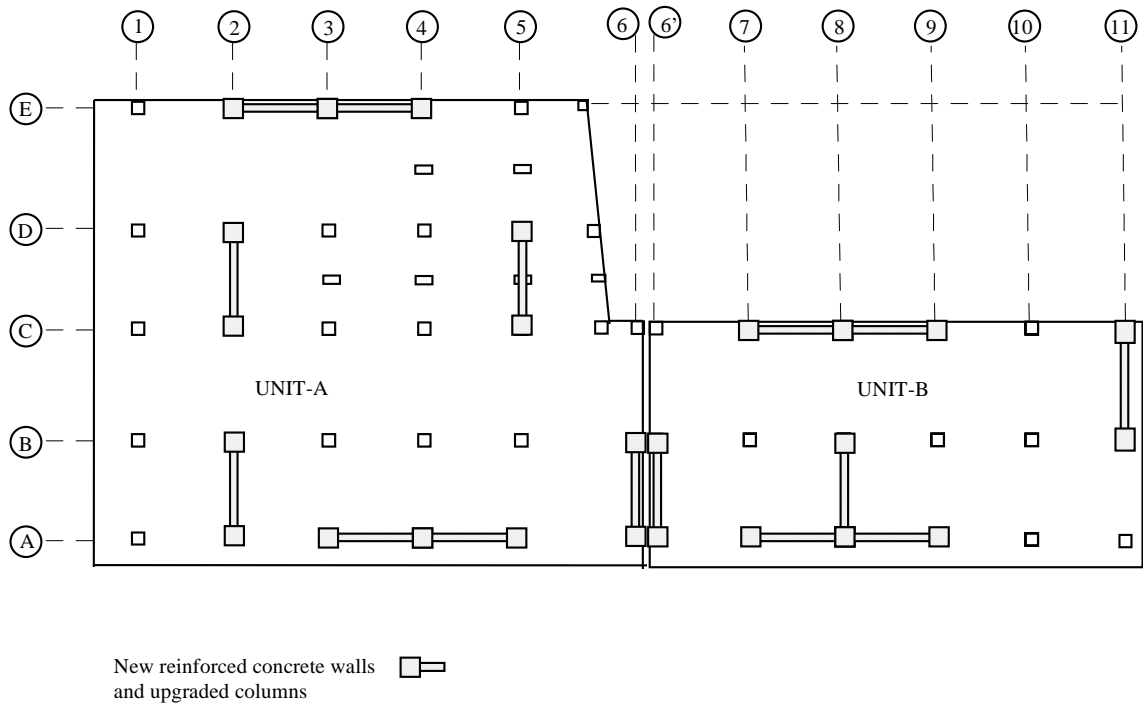

Figure 5.F12 Strengthening scheme.

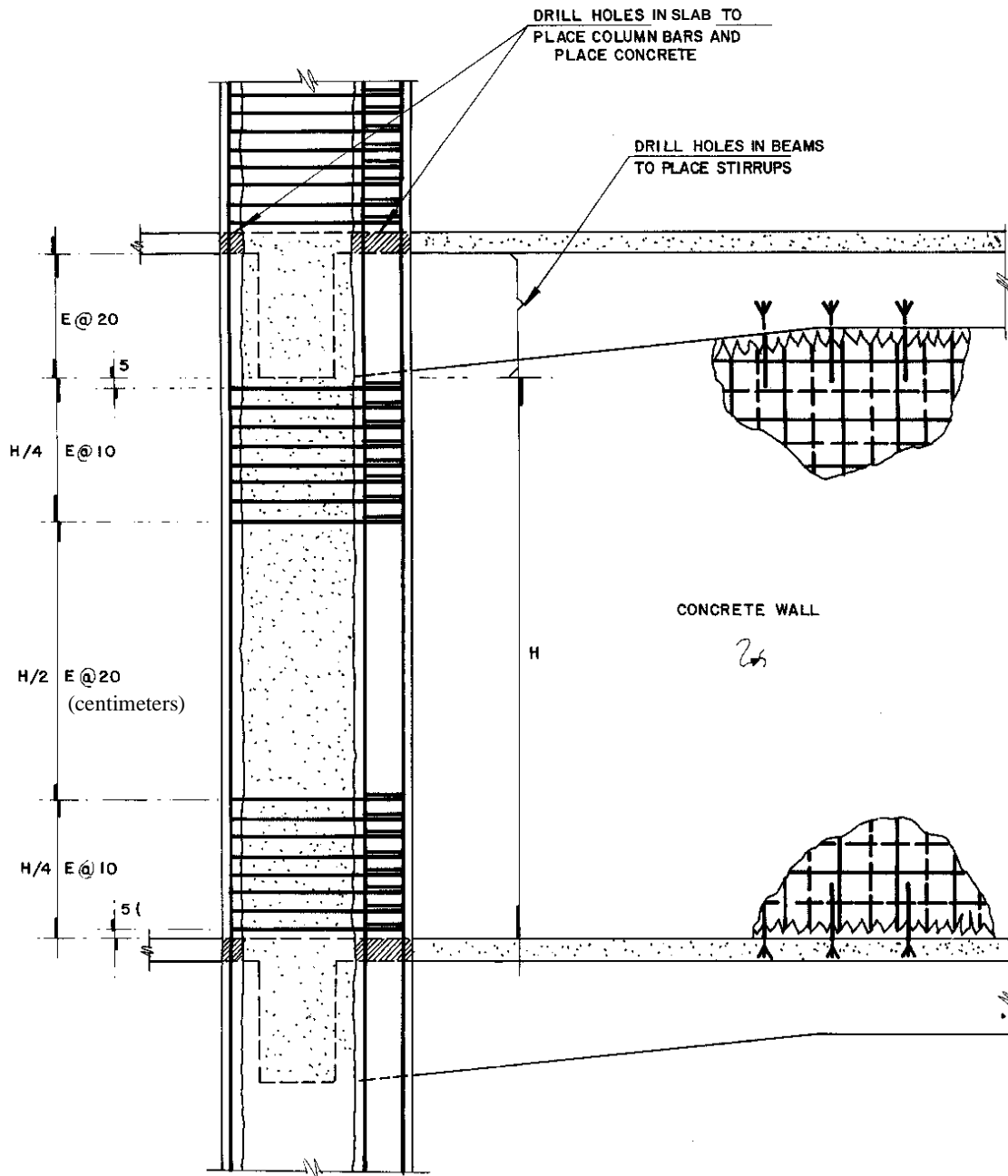

Figure 5.F13 Jacketing of existing columns and new concrete wall.

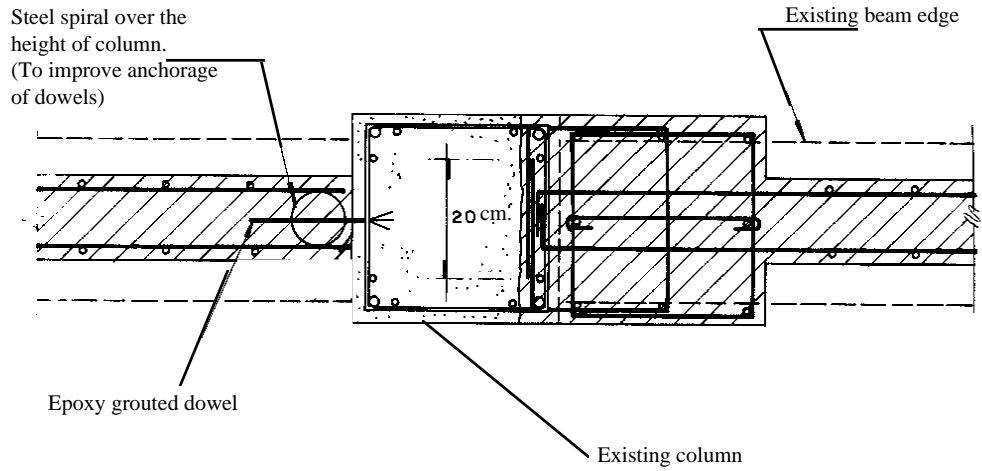

Figure 5.F14 Connection detail of new concrete wall in column C-5.

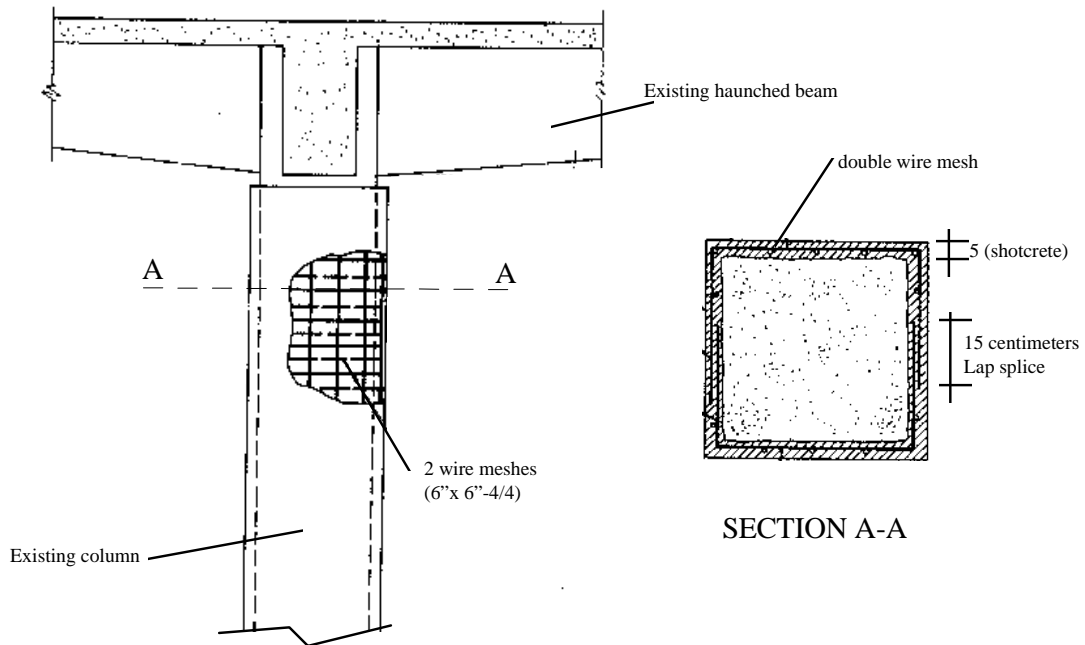

Figure 5.F15 Column jacking with shotcrete and wire mesh.



Figure 5.F16 Column jacketed with wire mesh and shotcrete.

To anchor the new reinforcement in the column jackets it was necessary to increase the width of the foundation beams. Retaining walls were connected to the upgraded foundation beams at the perimeter of the structure. It was considered unnecessary to add piles to the foundation.

5.8 BUILDING H

Building Description

The building was constructed in the lake zone of Mexico City in 1975. It is an office building with an area of approximately 291 m² per floor and includes a basement and seven floor levels (Fig. 5.H1 and 5.H2). The original structure was a waffle slab supported on reinforced concrete columns. The foundation system consists of a box foundation, 2.25 m deep forming the basement, supported by friction piles. There were masonry infill walls along boundary lines 1 and 4, and around the elevator shaft.

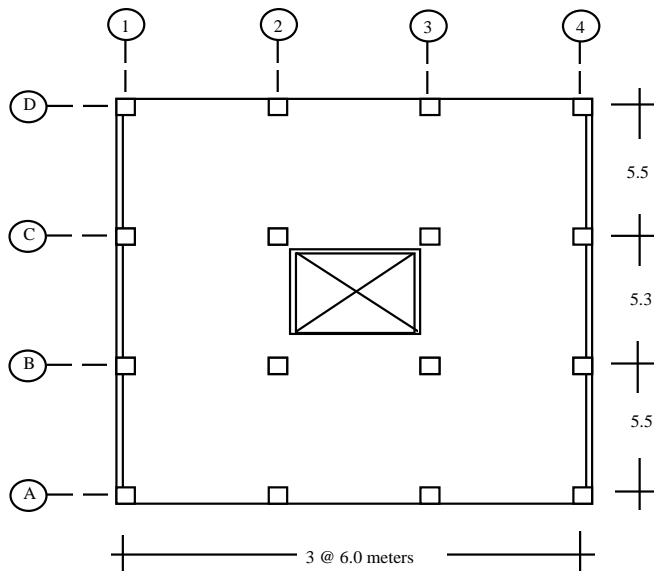

Figure 5.H1 Typical plan

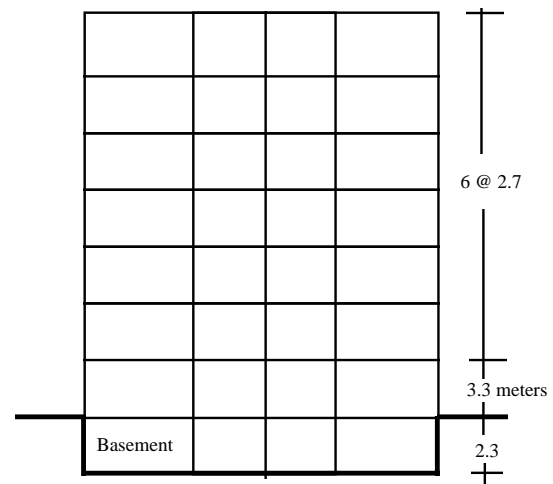

Figure 5.H2 Building elevation.

Description of Damage After the 1985 Earthquake

The most damaged structural elements were columns in the first three stories. The main cause of damage was the presence of masonry curtain walls on the back facade, line D, which were not isolated from the structural system. From the second to seventh story, curtain walls reduced the effective length of the columns to one half of the height between floors. These resulted in short column failure of column D-3, in the second story, and induced torsional effects (Fig. 5.H3).

Column A-1 had damage in third story due to pounding with the adjacent building. The roof of that building is at the mid story height of the column (Fig 5.H4 and 5.H5).

The columns around the elevator shaft and on line A had cracks, about 1 mm width, in stories 2 and 3. Also, masonry walls around the elevator shaft had severe

damage in those stories. The waffle slab was not damaged, but cracks due to punching shear were observed around column B-3 in the second floor.

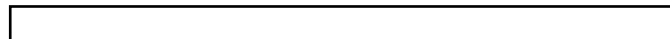

Figure 5.H3 Damage in column D-3.

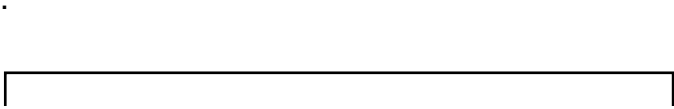

Figure 5.H4 Pounding with adjacent building.



Figure 5.H5 Damage in column A-1 due to pounding with adjacent building.

Temporary Measures

During retrofitting, shoring was provided from the basement to the third story to stabilize the existing structure, especially around the most damaged columns. The shoring consisted of wood elements placed as shown in Figure 5.H6. Timber braces were used, but were probably too light to provide lateral load resistance.



Figure 5.H6 Shoring in the lower stories.

Strengthening Procedure

The strengthening approach consisted basically of addition of concrete walls and concrete jacketing of columns in the lower stories. Two reinforced concrete walls, 25 cm width, were placed in boundary lines 1 and 4. Three walls, 20 cm width, were placed around the elevator core as shown in Figure 5.H7. All concrete walls extended from basement to the roof level and the boundary columns were strengthened with concrete jacketing. Ribs of the waffle slab along the column lines, from the basement to level 5, were upgraded and connected to the walls using the detail presented in Figure 5.H8.

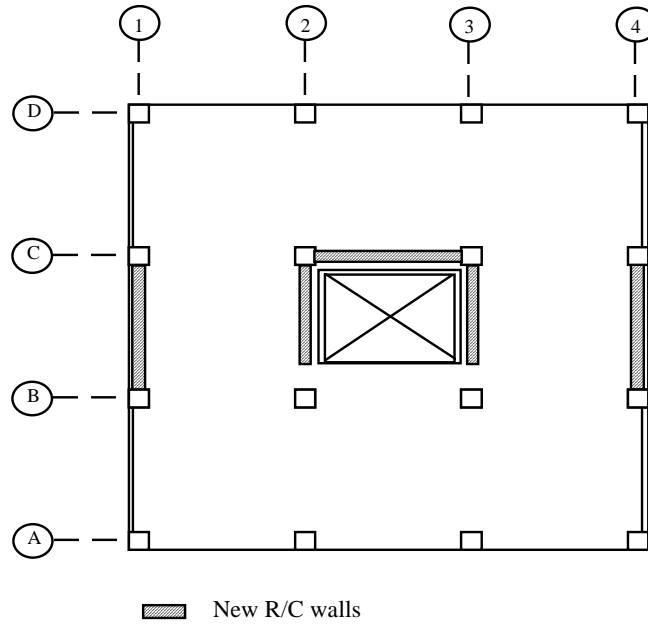

Figure 5.H7 Layout of new reinforced concrete wall.

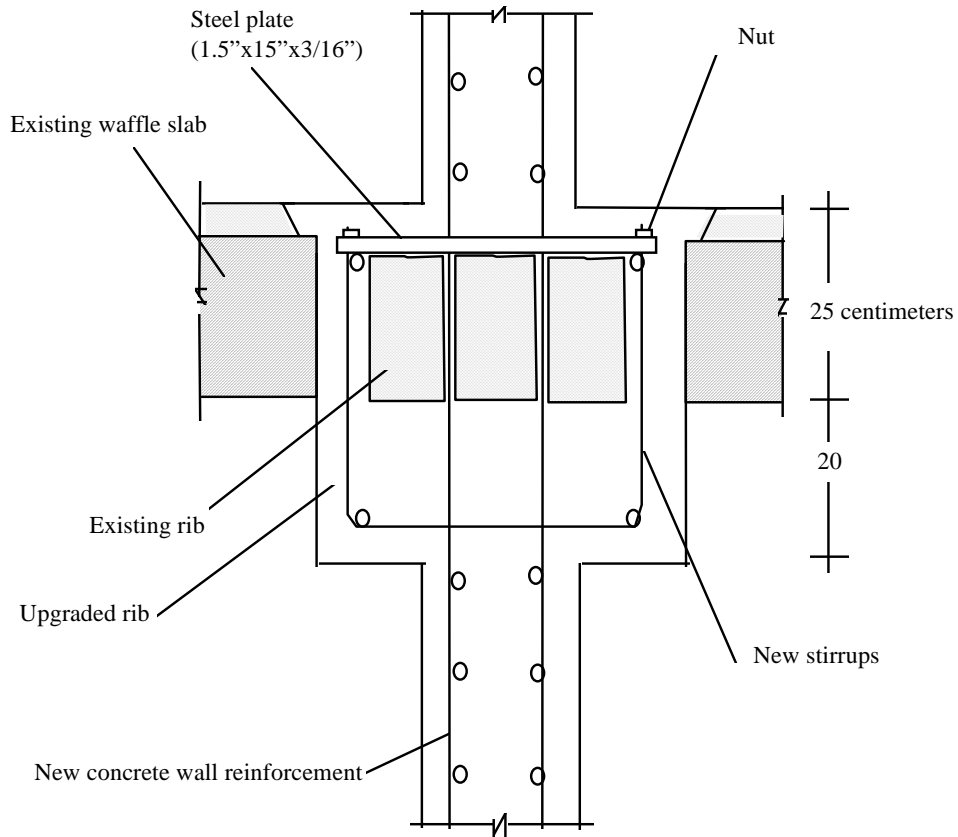

Figure 5.H8 Strengthening of ribs on column lines and connection with walls

The vertical reinforcement of the walls was extended into the existing foundation beams. For this purpose, the beams were partially demolished and recast using concrete with epoxy additive. The sectional area of the foundation beams was not increased or strengthened in any way (Fig. 5.H9).

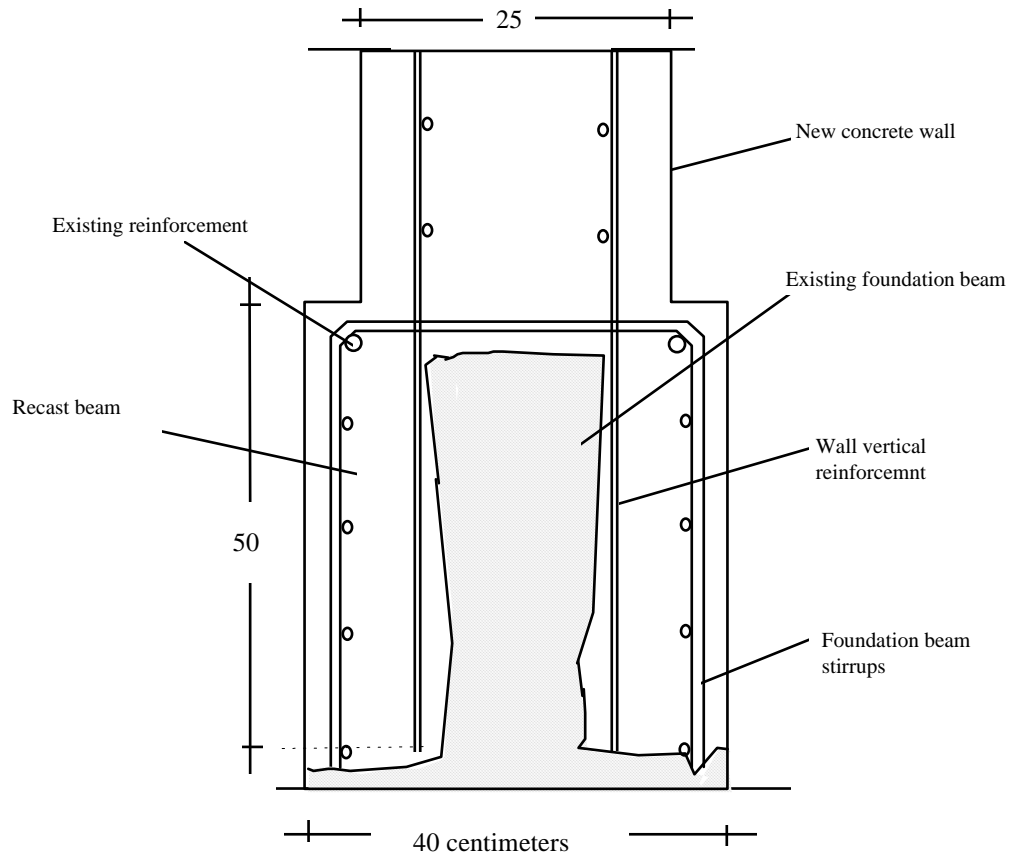

Figure 5.H9 Anchorage of concrete walls to foundation beams.

Jacketing with additional reinforcement was provided for all columns from the basement to the fifth level. Figure 5.H10 shows the jacketing columns on boundary lines 1 and 4. Severely damaged, columns A-1 and D-3 on the second level, were partially demolished and rebuilt.

It is important to note that the interior columns, which originally had a constant cross section had an abrupt change of section from level 5 (70x70 cm) to level 6 (45x45 cm) after jacketing.

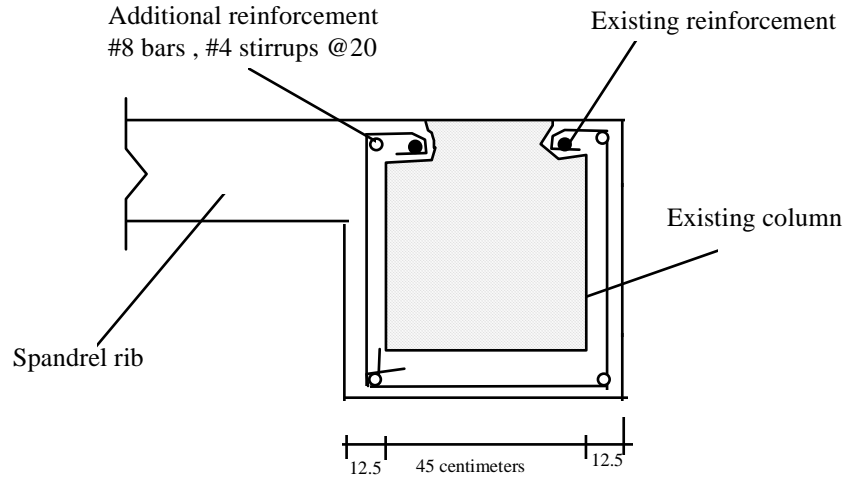

Figure 5.H10 Jacketing detail of column on boundary line.

Furthermore, cracked regions in ribs of the waffle slab around the columns were demolished and upgraded.

All the non-structural masonry walls were isolated from the rest of the structure to avoid short-columns problems.

It was necessary to add ten point-bearing piles, 25.5 m long, and foundation beams below the concrete walls. The concrete piles had an octagonal section and were placed in short lengths with a center hole core, in which reinforcement was driven. The hole was then grouted. Photographs of the installation of piles are shown in Figure 5.H11 and 5.H12.



Figure 5.H11 Installation of pile sections.

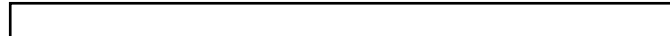

Figure 5.H12 Installation of pile sections.

5.9 BUILDING I

Building Description

The building is located in the lake bed zone in Mexico City. It has a basement and four stories above with an area of approximately 326 m² per floor (Fig. 5.11 and 5.12). The building is used to house heavy telephone switching equipment in the upper stories and an electric substation in the basement. There is an adjacent 2 story building along line A, between lines 5 and 8, whose roof coincides with the first level of this building.

The structure consists of reinforced concrete frames and two way slabs.

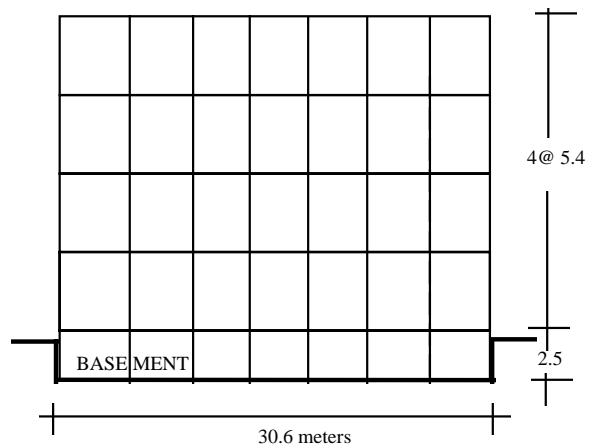

Figure 5.11 Building elevation.

Partitions and service core bearing walls are unreinforced hollow concrete block masonry walls. The foundation system is a concrete box, forming the basement, supported on control piles.

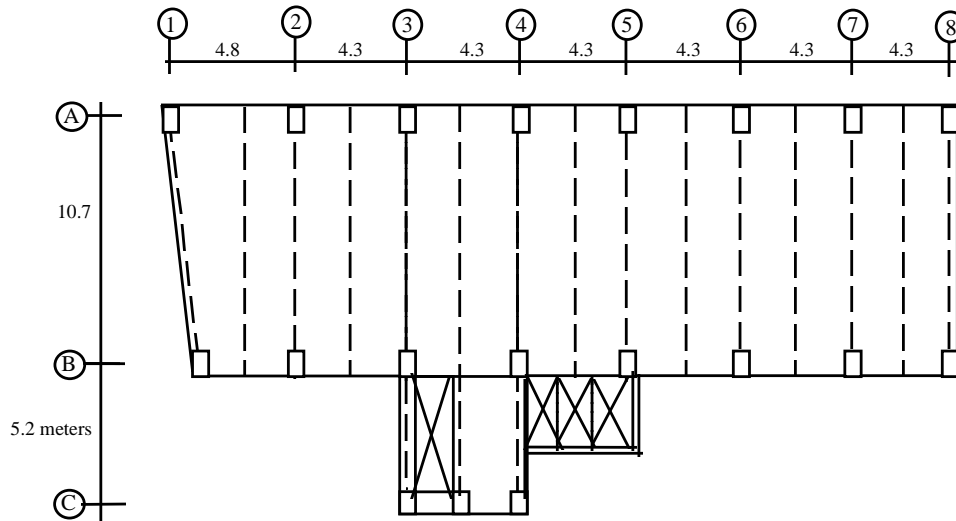

Figure 5.12 Typical plan.

Description of Damage After the 1985 Earthquake

The asymmetric building plan, due to the position of the service core, created torsional effects in the structure. Furthermore, there was pounding with the adjacent building because the separation was too small. As a result, the corner columns on line 8 were severely damaged, and spalling of concrete occurred at all levels. Also, the beam-column joints and beams on this column line had extensive diagonal cracking.

Nearly all the remaining columns experienced some cracking at all stories. Columns around the service core and on line A had cracks of more than 1 mm width. Also, all the beams had diagonal cracks in the first three levels, the most damaged were those on lines 1 and 8.

The slabs had been cracked before the 1985 earthquake. After the earthquake these cracks became more noticeable. None of the cracks was more than 1 mm wide.

The facade and service core walls were completely fractured in stories 2 and 3. The partition walls had moderate cracking. Most of these walls were hit by equipment (switching units) that were poorly fastened. In the original design, all walls were considered to be non-structural, but were, in fact, infill walls connected to the structural system.

In most control pile caps the threaded anchor rods of the control device buckled, as shown in Figures 5.13 and 5.14.

Temporary Measures

After the 1985 earthquake, shoring for vertical loads was provided in all stories and the telephone equipment units were protected with plastic covers and kept in operation, even during the retrofitting construction. The shoring consisted of braced wood elements with steel pipes carrying vertical loads, as shown in Figure 5.15.

For the strengthening project different alternatives were analyzed. The addition of concrete walls or steel bracing were considered the most feasible techniques. A decision was made to use concrete walls because the estimated time of construction was less and because the telephone equipment had to remain in operation. In the redesign, the intent was to eliminate torsional effects in the structure and to meet provisions of the 1985 Emergency Norms for structures of Group A, which includes communication buildings. An importance factor of 1.5 is applied for the seismic design.

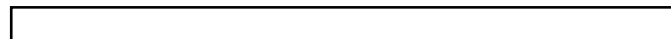

Figure 5.13 Buckling of anchor rods in control pile caps.



Figure 5.14 Damaged anchor rods in control pile caps.



Figure 5.15 Shoring system.

Strengthening Procedure

In the short direction, “C” shaped walls (25 cm thick) were placed at both ends of the building. Also, concrete walls (20 cm thick) were added to the service core and along line A. The walls were continuous from the foundation to the roof. The columns at the corners and the three columns on line C were demolished and recast along with the new walls. The arrangement of reinforced concrete walls is shown in Figure 5.16.

The columns in the boundary and outside the walls were jacketed with reinforced concrete. In Figure 5.17 a typical plan view of the column jacket is presented. The beams were jacketed only at the joint region over a length of about 1.10 meters from the existing columns. Figure 5.18 shows the alternatives used for beam jacketing. Alternative 2 was used in the beams below operating telephone equipment units, and alternative 1 for all others.

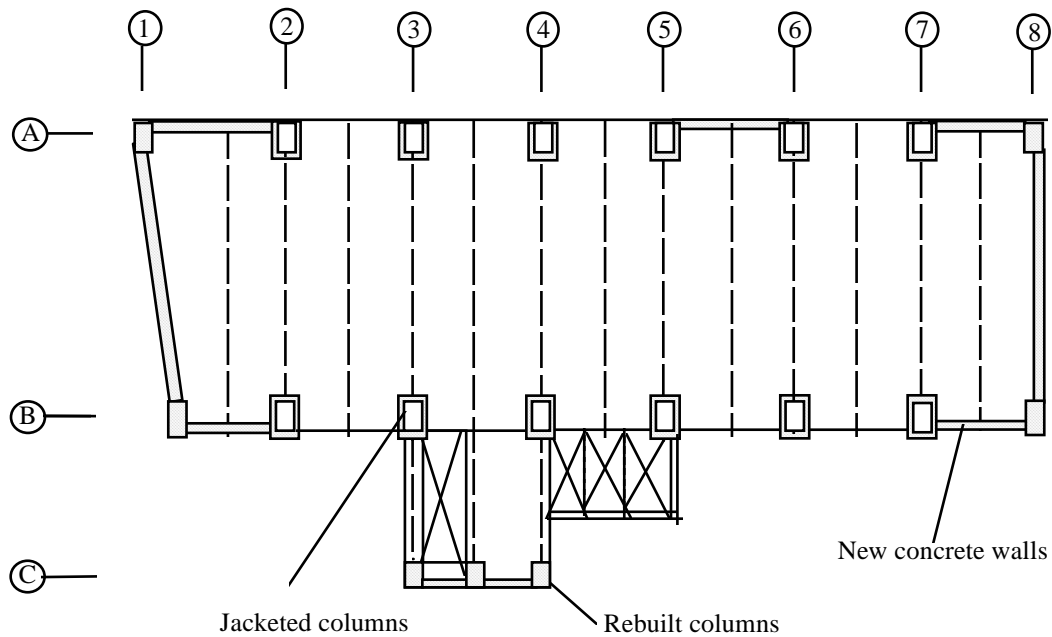

Figure 5.16 Strengthening plan.

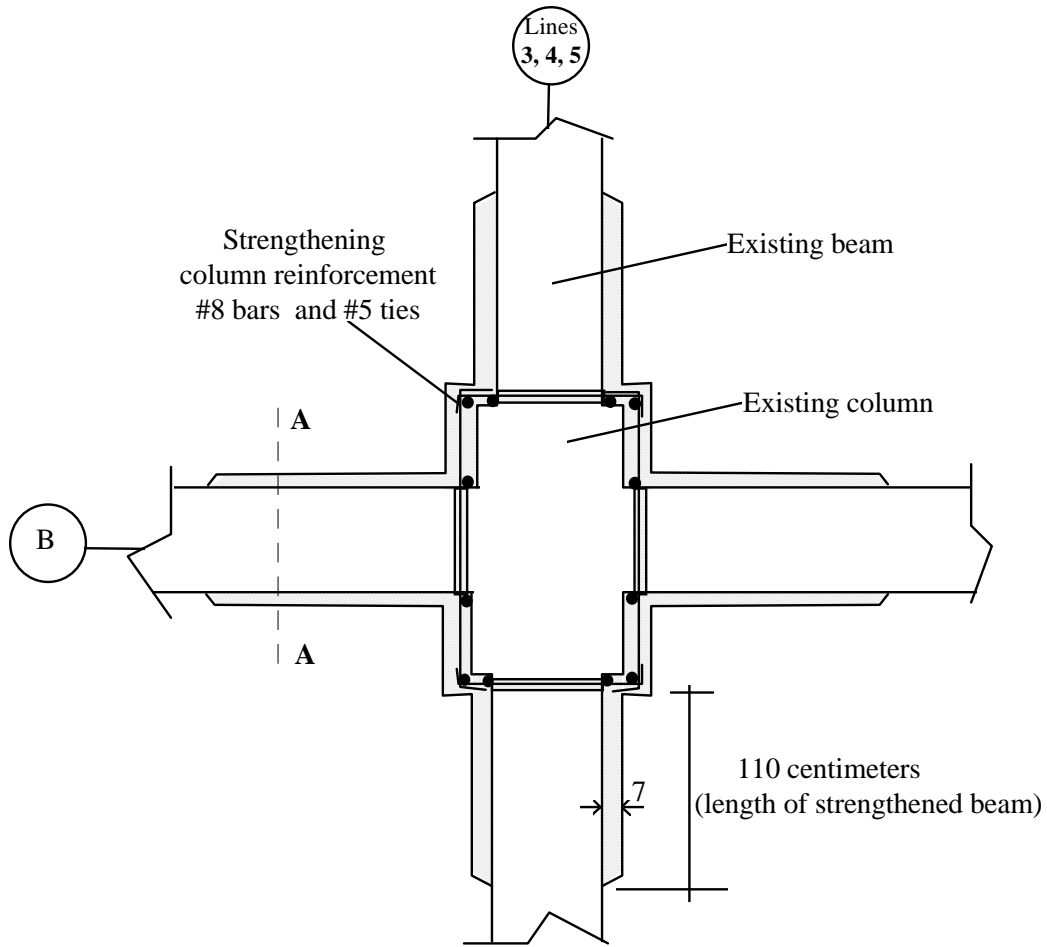

Figure 5.17 Jacketing of columns.

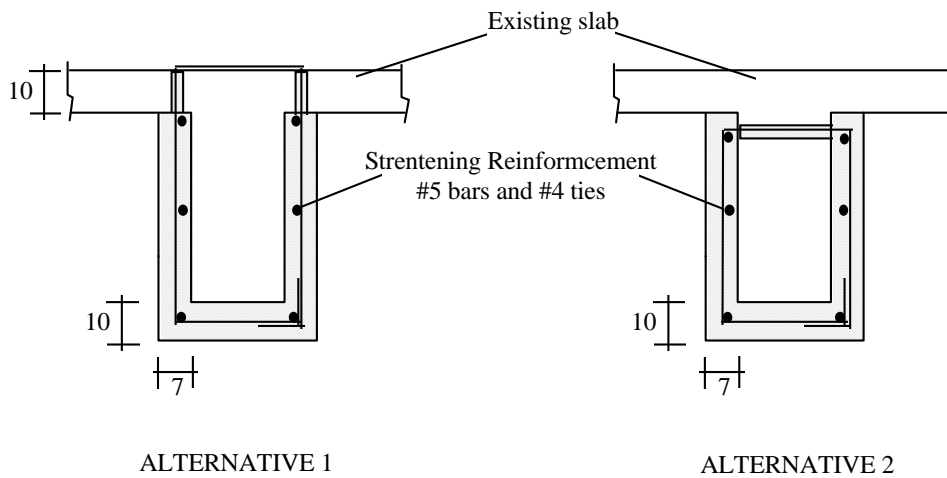

Figure 5.18 Detail of beam strengthening (Section A-A in Fig. 5.17).

The concrete strength used for retrofitting was $f'c=250 \text{ kg/cm}^2$ with additives to control volume changes. The existing structure was built with the same concrete strength. To increase bond between existing and new concrete, the surface of strengthened elements was chipped and wetted to saturation for at least two hours before casting. Cracks in existing elements with widths of 1.0 mm and greater were injected with epoxy resins prior to jacketing.

The foundation system, with 24 existing piles ($\varnothing=50 \text{ cm}$), was upgraded with 70 new control piles (30x30 cm, 27.0 m long) beneath the concrete walls. The damaged pile control devices were replaced, as shown in Figure 5.19. The foundation slab was also upgraded by adding a new slab on top of the existing slab along the perimeter of the building where the new piles were placed.

The building's configuration and the strengthening scheme allowed maintaining the building's operation. According to the telephone company, the equipment in this building which controls 28,000 telephone lines maintained operations at 98% of capacity during the construction work. The retrofitted building is shown in Figure 5.110.



Figure 5.19 New control devices on pile caps.



Figure 5.110 Retrofitted building.

5.10 BUILDING J

Building Description

The building is located in the lake bed zone of Mexico City, west of the downtown area. The structure was built in 1974 and is used as an office building. It is six stories high with a basement and a penthouse. The approximate floor area is 460 m². (Fig. 5.J1 and 5.J2).

The original structural system consists of reinforced concrete columns with a waffle slab floor. The foundation is a box foundation on friction piles. The infill walls on the boundary lines A and D and the partitions are of solid clay brick masonry.

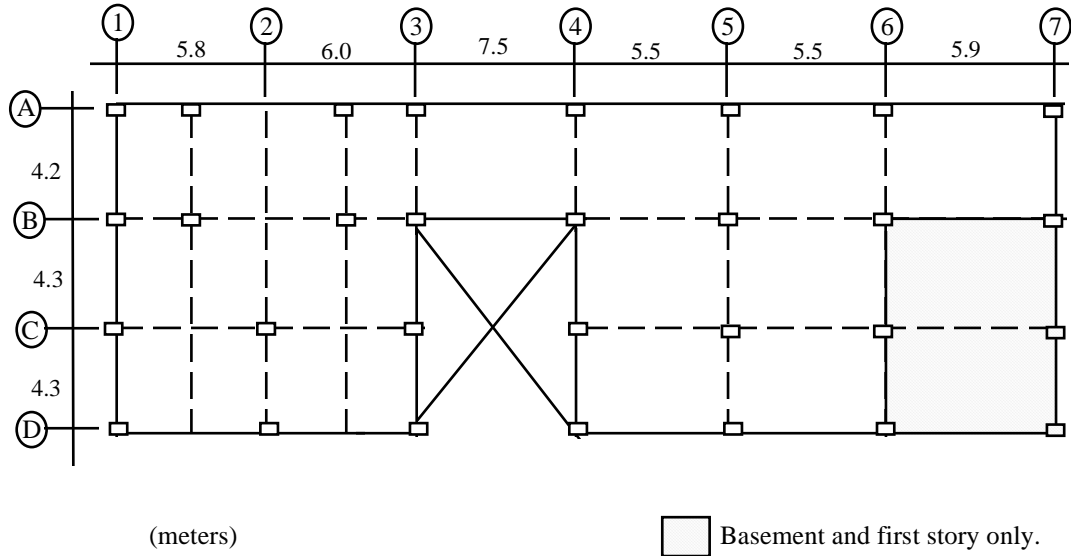

Figure 5.J1 Building plan.

Description of Damage After the 1985 Earthquake

The columns and the waffle slab were not damaged. The perimeter masonry walls on lines A and D and some of the partitions had minor cracks from story 1 to 3. Most of the plaster on walls was lightly cracked.

Although a structural review of the building indicated it was unnecessary to undertake a major rehabilitation, the owners made the decision to upgrade the building and achieve the seismic safety requirements of the 1985 Emergency Norms. This decision was induced by a feeling of insecurity on the part of the owners who were occupants of the building and witnessed severe damage and collapse of several medium-rise buildings in the neighborhood. Furthermore, cracking of the walls increased the owners' concern.

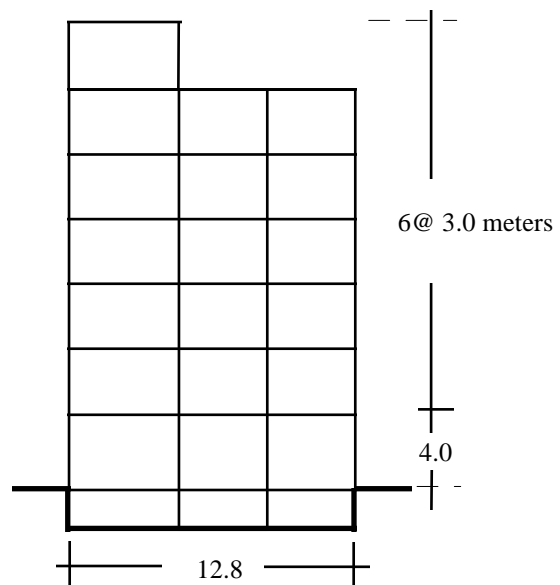

Figure 5.J2 Building elevation.

Temporary Measures

Since the structural members were not damaged, it was not necessary to shore the building, even during retrofitting work.

A retrofitting approach was developed to focus on increasing the stiffness of the structure, particularly in the short direction. The project consisted of adding steel bracing to four frames in the short direction, and strengthening the perimeter masonry walls with wire mesh and shotcrete in the long direction.

It was assumed that lateral loads in the short direction would be carried only by the braced frames, and vertical loads would be carried by the existing structure. The unbraced frames provided a second line of strength.

Also, it was assumed that the existing masonry would work monolithically with the reinforcement on its surface and would reach maximum capacity at the same time.

Strengthening Procedure

The steel bracing was placed on the middle of the frames on lines 1, 3, 4 and 6 from the ground floor to the roof (Fig. 5.J3). The steel braces were formed of two welded angles. The boundary columns were jacketed with steel angles at the corners by straps. Details of the bracing and jacketing are shown in Figures 5.J4 and 5.J5. The bracing elements were added symmetrically to avoid torsional effects in the case of an earthquake during construction.

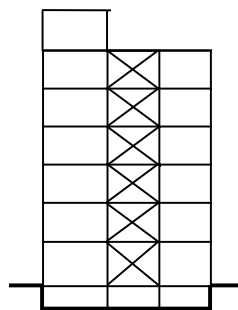
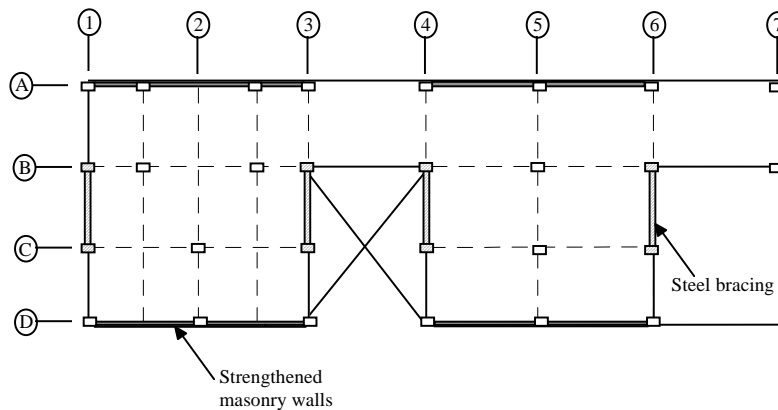

ELEVATION ON LINE 6

Figure 5.J3 Strengthening scheme.

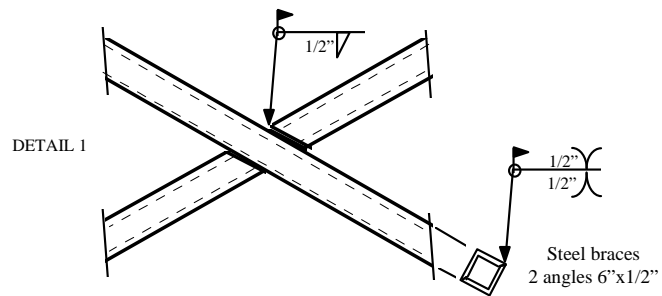
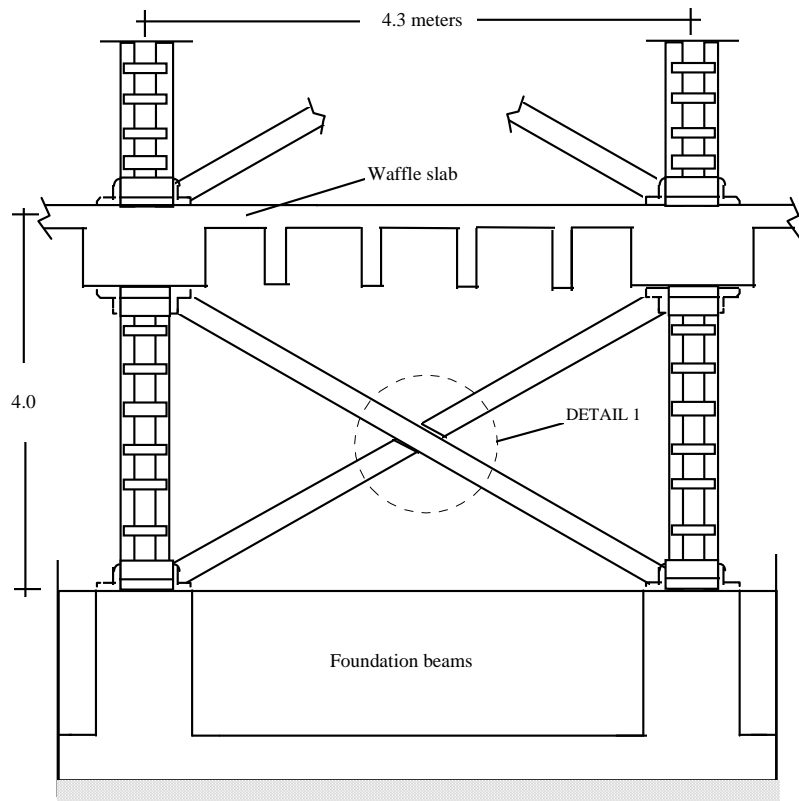
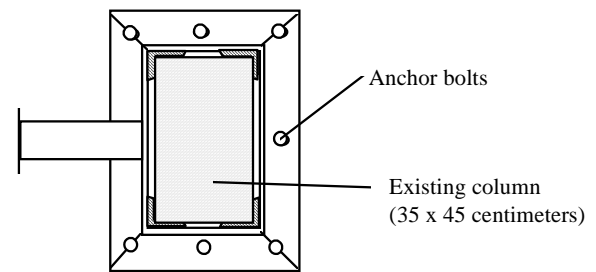
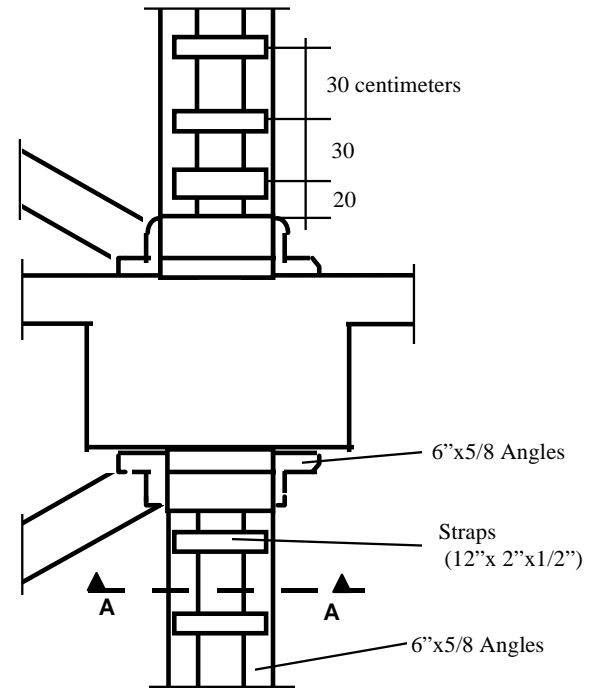

Figure 5.J4 Steel bracing.



SECTION A-A

Figure 5.J5 Column jacketing details.

The masonry infill walls on lines A and D were strengthened by first filling all the cracks with a cement and sand (1:3) grout and an additive to control volume changes. The interior faces of the walls between axes 1 and 3, and 4 and 6 were covered with a welded wire mesh, fastened with 4" nails, and a layer of shotcrete. To anchor the mesh to the existing walls, new concrete boundary elements were built integrally with the new concrete cover (Fig. 5.J6).

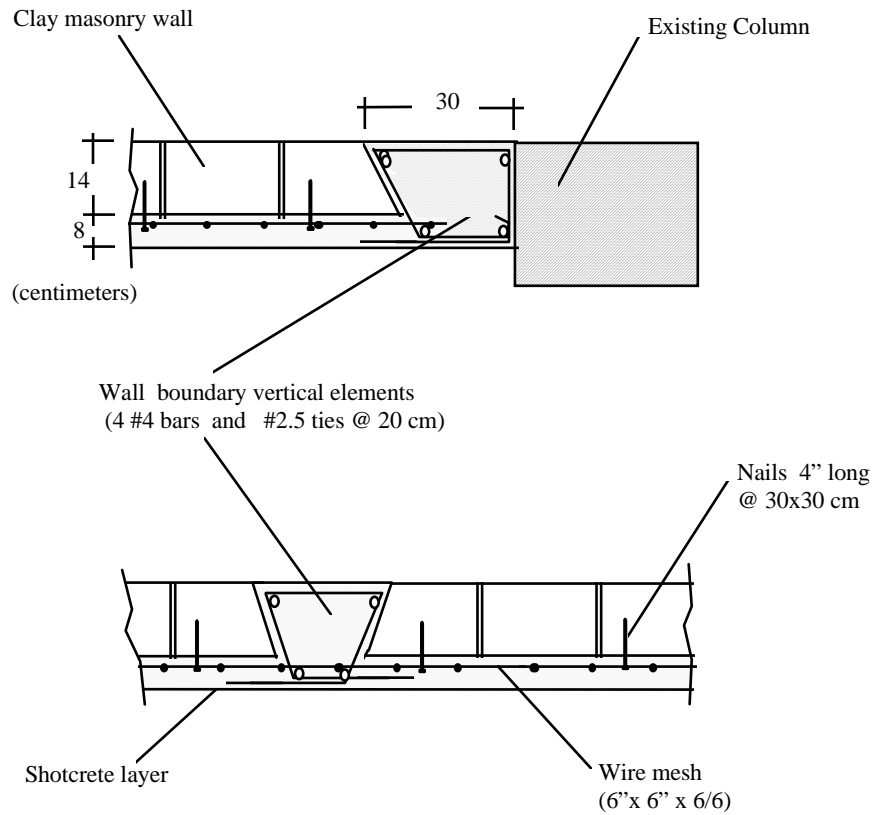

Figure 5.J6 Strengthening of boundary masonry infill walls.

The steel braces can be seen in Figures 5.J7 and 5.J8. The square elements attached in the center of the braces were added only for aesthetic purposes.

There were no modifications to the foundation system.



Figure 5.J7 Steel bracing in the building facade.

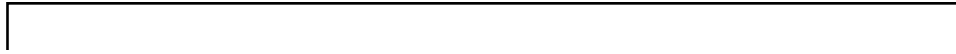

Figure 5.J8 Steel bracing in the upper levels.

5.11 BUILDING K

Building Description

The building was constructed in 1979-1980. It has 18 levels, divided into a basement for parking, ground floor, three more levels for parking, 12 levels of offices and a machine room (Fig. 5.K1 and 5.K2). The total area of construction is 21,946 m². The structure is formed of reinforced concrete columns with a waffle slab. The foundation is partially supported by piles. The building is located in the zone considered to be a transitional soil of the lake bed in Mexico City. There is a clay layer 18.5 m thick above the first hard layer of soil.

Description of Damage After the 1985 Earthquake

The structure had light damage due to the 1985 earthquake. The waffle slab's ribs showed many small cracks (<1 mm) in the region near the column axes and rigid zone around columns. Most of the damaged ribs were located in the upper stories. Damage was not observed in the columns.

After the earthquake a complete structural review of the building was done. The review included a comparison of the design drawings with the as-built condition. Also concrete core tests and measurements to check the verticality of the structure were carried out. Experimental vibration tests were used to determine the dynamic characteristics of the building.

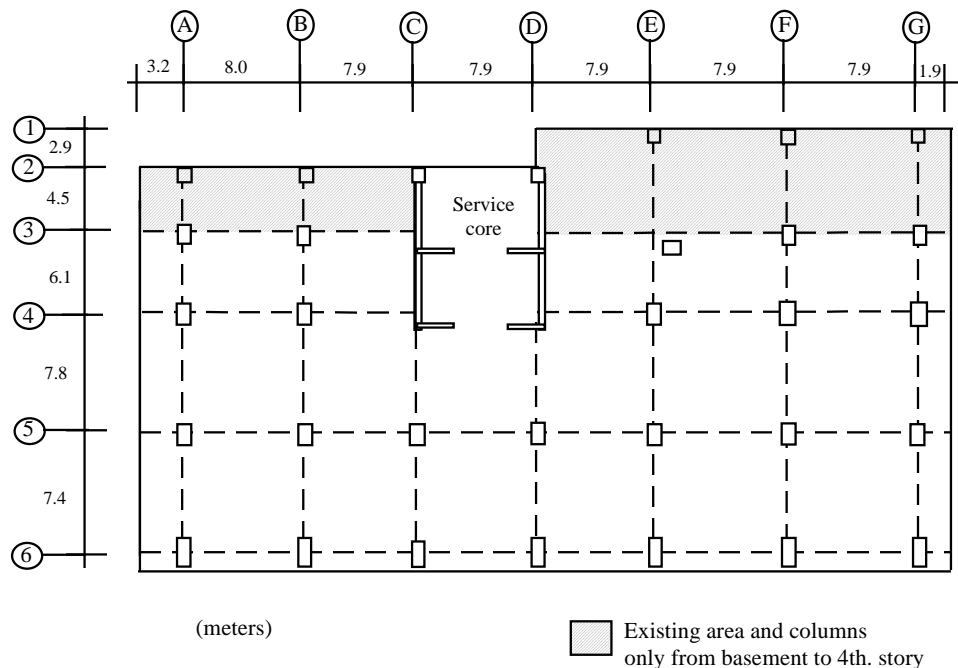

Figure 5.K1 Building plan.

The structural review indicated that there were eccentric slab-column connections that differed from the design drawings (Fig. 5.K3). Some tilting of the building was detected but there was not enough evidence to conclude that the problem was due to the earthquake. The report of the concrete core tests for the rigid zone (solid section near columns) of slabs showed that the actual concrete strengths were 60% higher than the nominal design strength and 20% higher for columns.

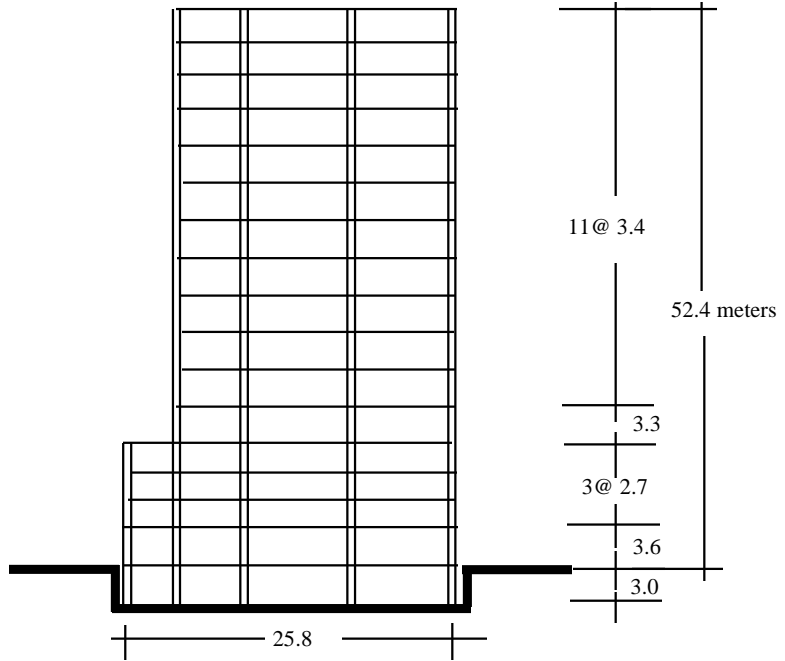

Figure 5.K2 Elevation on line A.

In addition to the vibration tests, a study of the properties of the soil was performed in order to obtain information for generating site spectra for the seismic analysis of the building.

Temporary Measures



Figure 5.K3 Eccentric slab-column connection.

The building was reviewed to determine if it complied with the requirements of the Emergency Norms of 1985. It was analyzed using site spectra corresponding to the earthquake of September 19, 1985 and it was found that the structure did not comply with the safety levels required by the Emergency Norms.

On the basis of the results of the seismic analysis, recommendations were made for reinforcing the structure to increase its capacity to lateral loads. Different structural systems were analyzed for reinforcing the building to reduce seismic displacements and ductility demands. The following five alternatives were analyzed:

a. Shear wing walls at exterior grid lines.

This scheme involves adding reinforced concrete “wing walls” at the columns along lines A, G and 6 (Fig. 5.K1) in the 18 stories. Also exterior (or end) walls were added on lines A and G between axes 1 and 3. Lateral stability for these walls was provided by using triangular slabs anchored in the existing floor slabs in the 6th story and above (Fig. 5.K4).

b. Steel bracing.

In this alternative, steel braces were used to strengthen the building along lines A, G and 6 using steel bracing as shown in Figures 5.K5 and 5.K6.

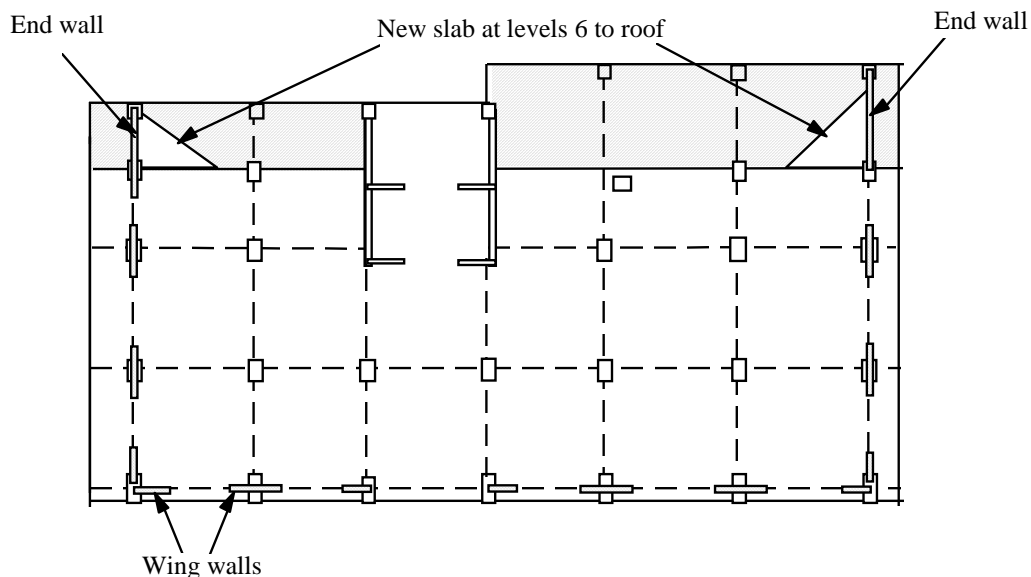

Figure 5.K4 Shear walls in exterior bays.

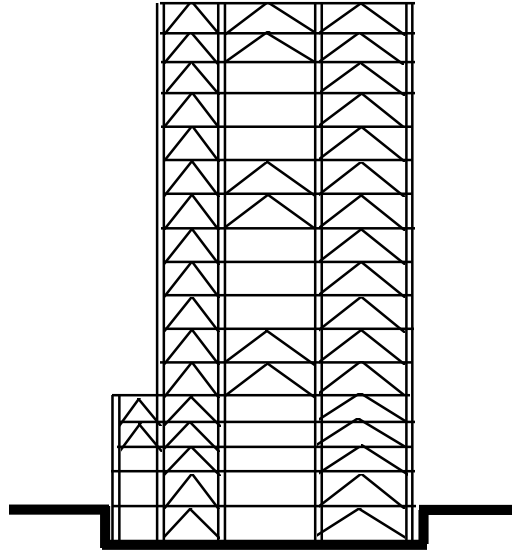

Figure 5.K5 Steel bracing on line A.

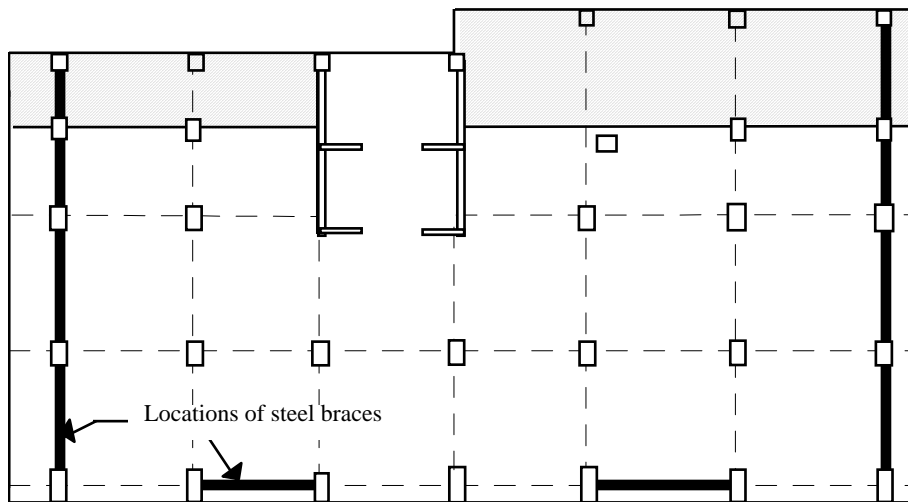

Figure 5.K6 Steel bracing alternative, plan view of brace locations.

c. Steel frames at exterior grid lines.

In this proposal steel frames were to be connected in parallel to the reinforced concrete frames at grids A and G.

d. Removal of upper floor levels.

This alternative consisted of removing the upper four levels of the building.

e. Steel girders over main frame lines.

The proposal consisted of placing steel girders along all main frame lines and connecting them to existing beams to create composite beams in both directions of the building.

f. "Macro-frames".

The "Macro-frame" scheme consisted of developing large exterior frames by increasing the size of the existing columns and beams along the perimeter grid lines. Figure 5.K7 shows this alternative schematically.

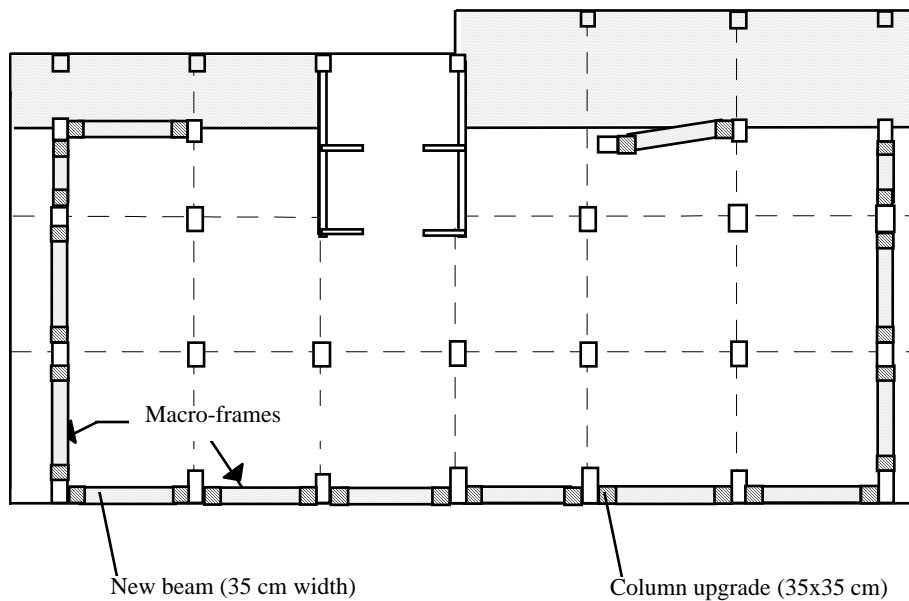

Figure 5.K7 Alternative of large perimeter frames.

For each of the six alternatives a representative structural model was analyzed under gravity loads and site ground motions, using a soil-structure interaction model. The ductility demands of the strengthened structure were compared with the existing structure. Also, the impact of the strengthening technique on the foundation was evaluated. The feasibility of constructing the strengthening technique was studied.

On the basis of the preliminary analysis, a technical cost evaluation of the different alternatives studied was completed in order to select the best project. A comparison of different parameters for each alternative is shown in Table 5.K1.

Alternative	Period ⁽¹⁾ sec.	Max. story drift ⁽²⁾ cm.	Additional piles needed	Estimated total cost ⁽³⁾ of reinforcement (dollars)
Original building	2.60	7.8 (15)	--	--
a. Wing walls	2.31	3.1 (15)	39	235,000
b. Steel bracing	1.86	3.6 (15)	14	241,000
c. Ext. Steel frames	2.30	6.5 (6)	0	1,157,000
d. Eliminating levels	1.87	6.8 (7)	0	350,000
e. "Macro frames"	1.87	2.0 (14)	18	391,000

⁽¹⁾Fundamental period

⁽²⁾Story Height = 410 cm. Number of story in brackets.

⁽³⁾The cost of labor and materials are based on values for 1988.

Table 5.K1 Results of preliminary analysis.

It was observed that the steel bracing and macro-frames option had several technical advantages related to other alternatives: lowest periods of vibration, considerable reduction in the ductility demands, reduction of story drift as well as fewer piles required.

The wing wall alternative was also satisfactory but it required more piles than the other schemes. Foundation modifications are a major construction problem in strengthening existing buildings. As a result of the studies, the steel braced frame was chosen as the system to be used because it combined the best economic and technical solutions.

Strengthening Procedure

The bracing system was designed with box sections, formed with two steel angles. Figure 5.K8 shows a typical steel brace at grids A, G and 6. The slab-column joints in the base of the steel braces were encased with steel plates above and below the floor (Fig. 5.K9). The steel elements were connected with the existing structure using high strength bolts.

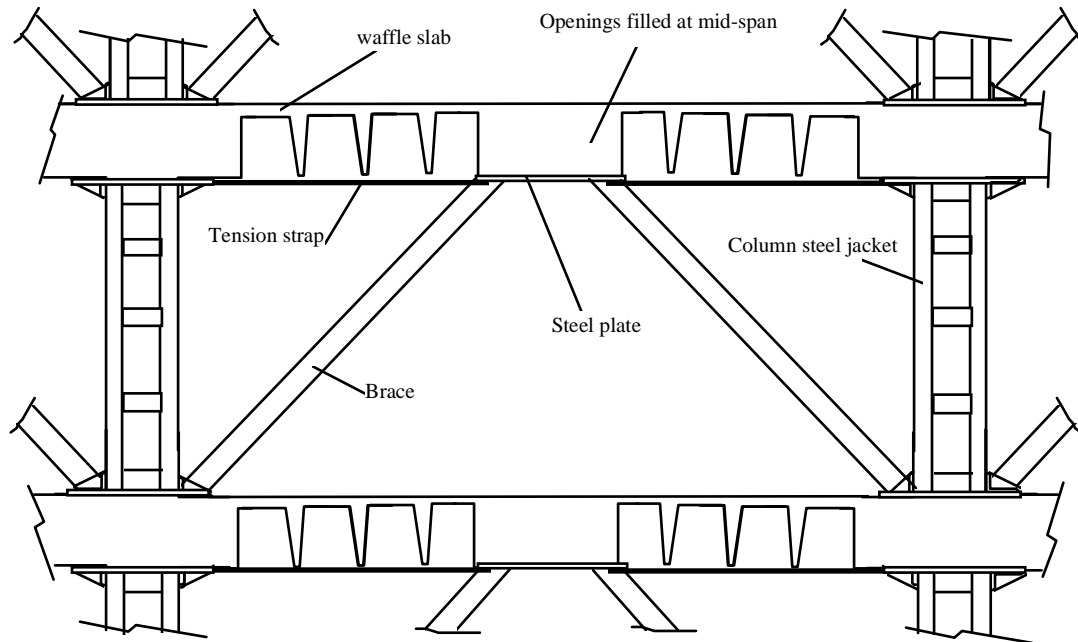

Figure 5.K8 Detail of the steel bracing system.

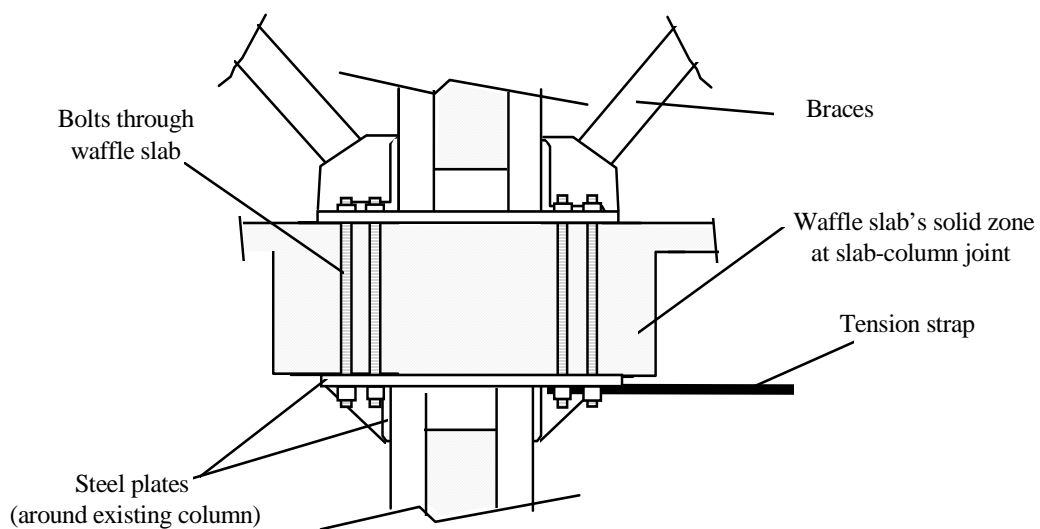

Figure 5.K9 Typical detail of brace connection at joints.

Steel jacking was used to reinforce the columns bounding the braced bays. At the midspan between columns where the braces are connected to the floor, the voids in the waffle slab were filled with reinforced concrete to create a solid zone with a steel plate below. The top of the jacketed columns was connected to the midspan steel plate by tension steel straps. A detail of the midspan connection is shown in Figure 5.K10.

The foundation was strengthened with new piles, 35 cm diameter and 19.5 m long, penetrating into the hard soil layer.

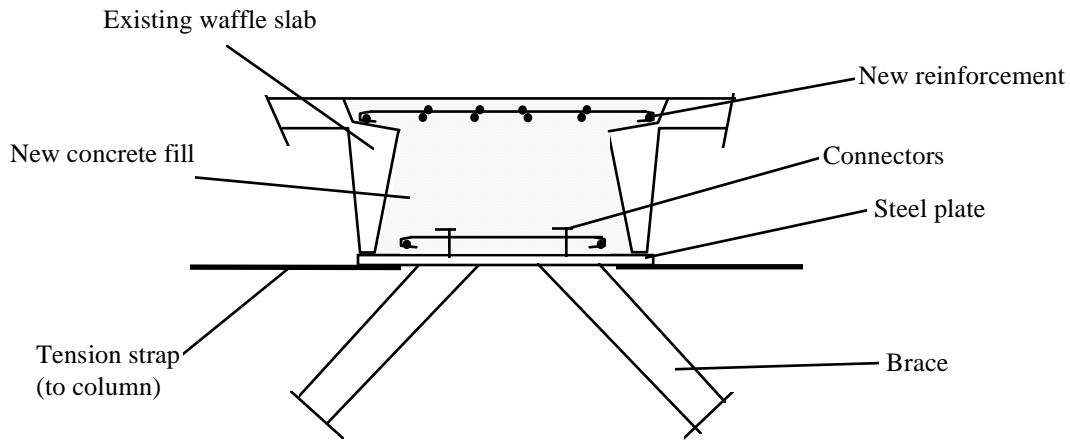

Figure 5.K10 Connection detail midway between columns.

5.12 BUILDING L

Building Description

The building is a reinforced concrete structure with fourteen floors and a basement. It is a long narrow building (1 bay by 7 bays) with an area approximately 420 m² per floor (Fig. 5.L1 and 5.L2). The structure consists of reinforced concrete frames with a solid concrete slab. The second floor (mezzanine) concrete slab is supported by steel beams in both directions. The foundation is partially supported by 26 m. long piles. The building is located in the lake bed zone of Mexico City.

In the 1957 earthquake, the building suffered severe structural damage to the columns. It was repaired and strengthened by increasing the size of some columns but without significant additional reinforcement. The exterior frame in column line 8 was stiffened with reinforced concrete braces and masonry infill walls as shown in Figure 5.L3.

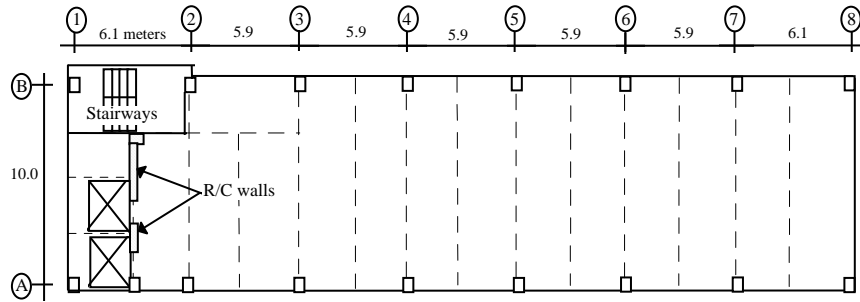

Figure 5.L1 Typical building plan.

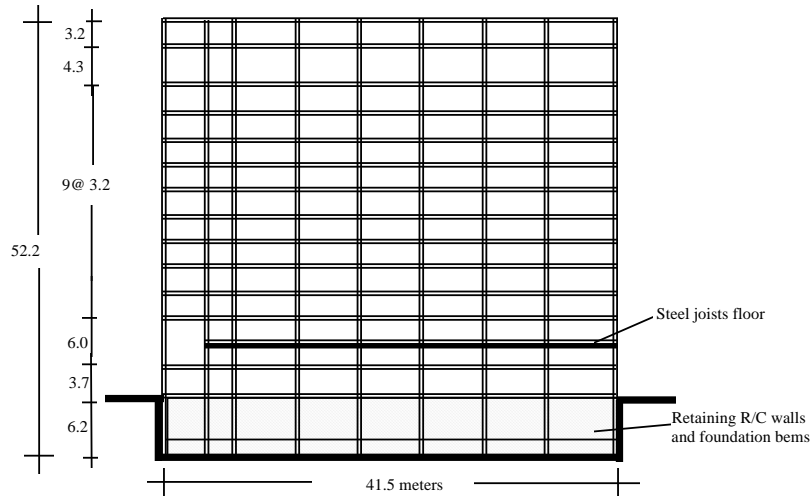

Figure 5.L2 Building elevation on line A.

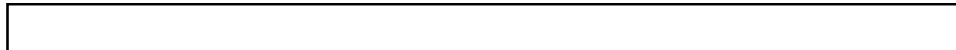

Figure 5.L3 Existing concrete braces in column line 8.

Description of Damage After the 1985 Earthquake

The columns at lines 1 and 2 near the elevators suffered severe damage in all stories. The rest of the columns had lighter damage. The slab and beams were extensively cracked in all stories. The partition masonry walls had large cracks. The most damage was in the two top stories.

Temporary Measures

Following the 1985 earthquake, a structural review of the building recommended removal of the two upper levels of the building and removal of the floor finishes to reduce the weight of all the slabs. However, it was decided to develop a rehabilitation alternative which would increase the stiffness of the building without adding excessive mass or reducing the floor area. The strengthening approach consisted of installing a steel bracing system or walls and steel jacketing of beams and columns (Fig. 5.L4 and 5.L5).

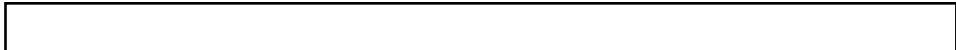

Figure 5.L4 Steel braces in long direction (line A).



Figure 5.L5 Steel braces in short direction.

Strengthening Procedure

The frame on boundary line “B” which faced an adjacent building was strengthened with reinforced concrete walls and masonry infill walls in the five lower levels. The upper levels were stiffened with steel X-braces between lines 4-5 and 7-8 (Fig. 5.L6). Frame “A” which faced the street was strengthened with X-braces between lines 2-3, 4-5 and 6-7 in all the stories (Fig. 5.L7). A reinforced concrete wall was added between lines 1 and 1’ in all stories. The new wall was connected to column line 2 with coupling beams (Fig. 5.L8 and 5.L9).

In the short direction in frames 3,4,5 and 6, W-braces were constructed on alternate floors creating a staggered brace system as shown in Figure 5.L10.

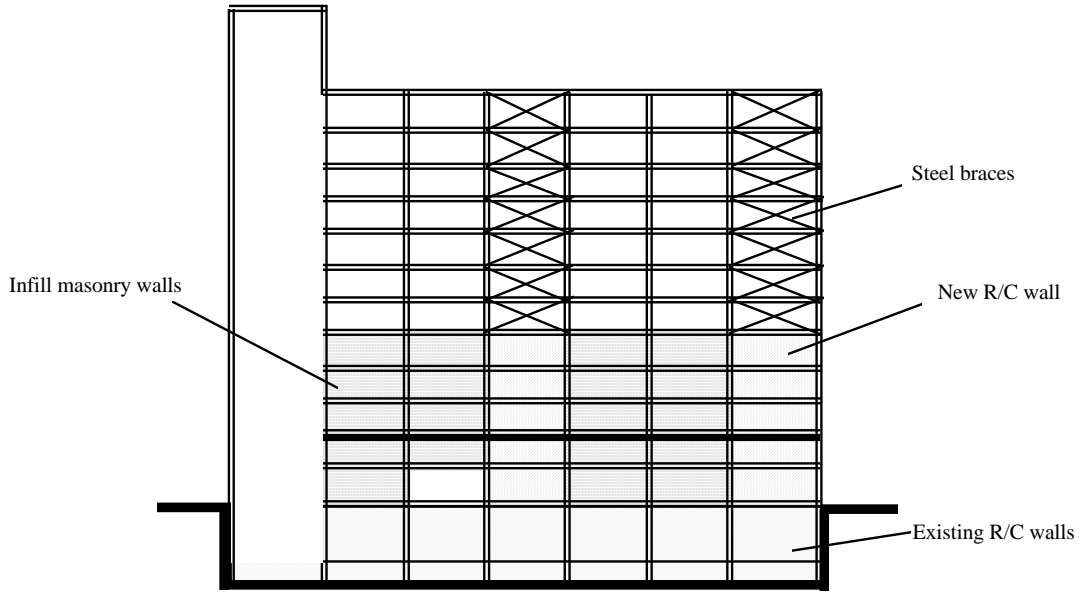

Figure 5.L6 Frame on line B.

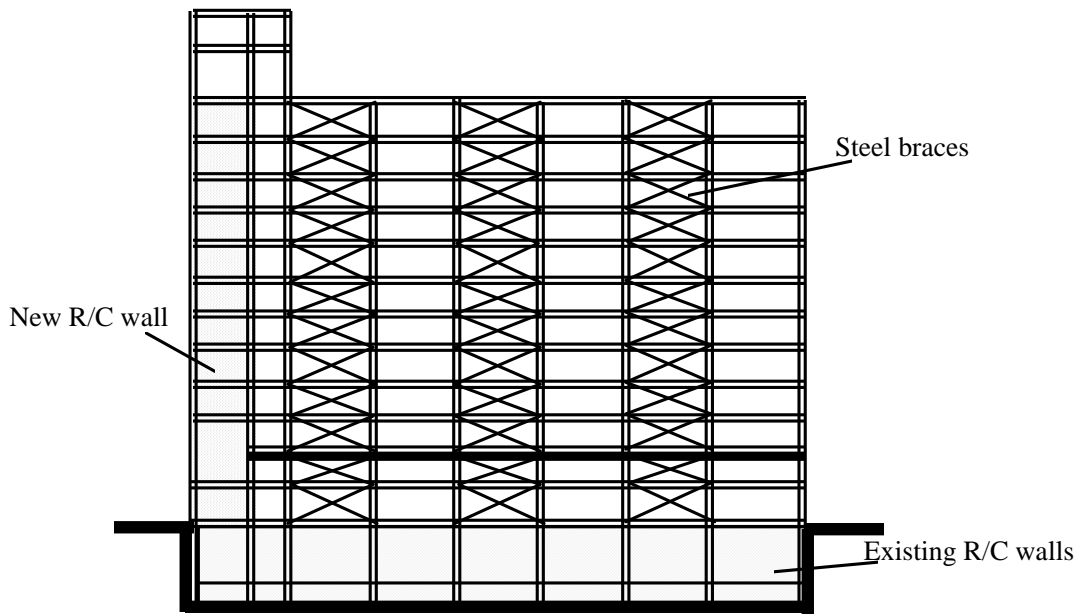

Figure 5.L7 Frame on line A.



Figure 5.L8 Reinforcement in new concrete wall.

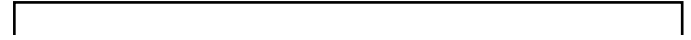

Figure 5.L9 Reinforced concrete wall in line A.

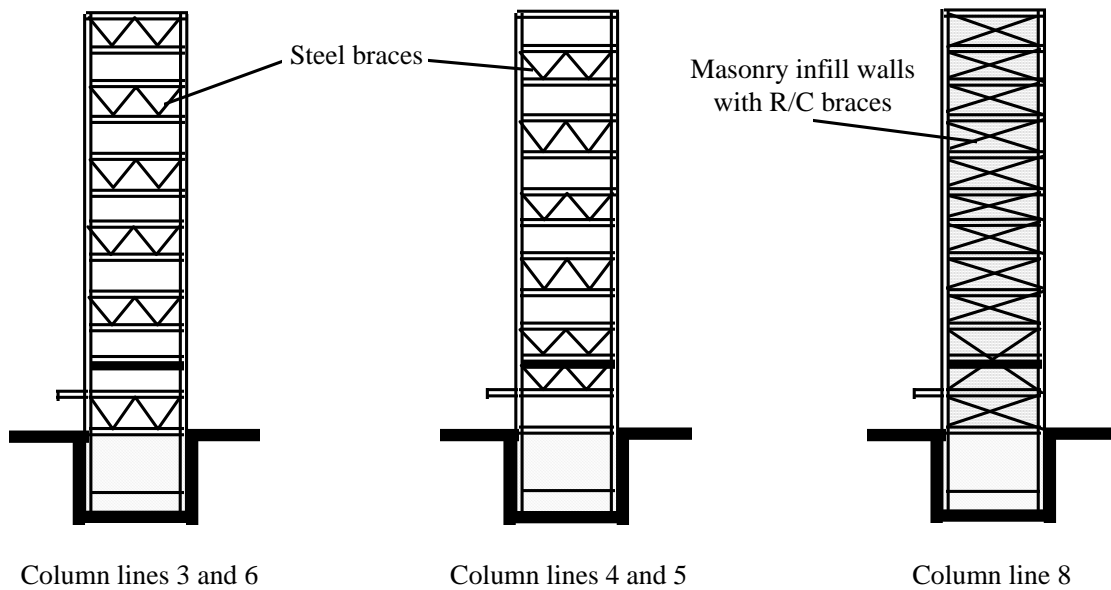

Figure 5.L10 Frames in short direction.

The connections between the braces and beams were made using steel base plates. The base plates were bolted to a steel box around the bottom of the beams as shown in Figures 5.L11 and 5.L12. The damaged concrete braces and masonry walls in line 8 were removed and rebuilt increasing the reinforcement in the braces (Fig. 5.L13). The masonry infill walls on line 1 were restored without changes.

Columns and beams along column lines were jacketed with steel elements and connected to the bracing system, as is shown in Fig. 5.L12 and 5.L14. The thickness of the slabs was increased with a reinforced concrete layer over the existing slabs in all floors. The new slab was attached to the existing slab using 1/2" steel connectors at 1 m. in both directions (Fig 5.L15).

Because of the changes in the superstructure, 56 new piles were added to the 26 existing piles and new foundation beams were constructed (Fig. 5.L16).

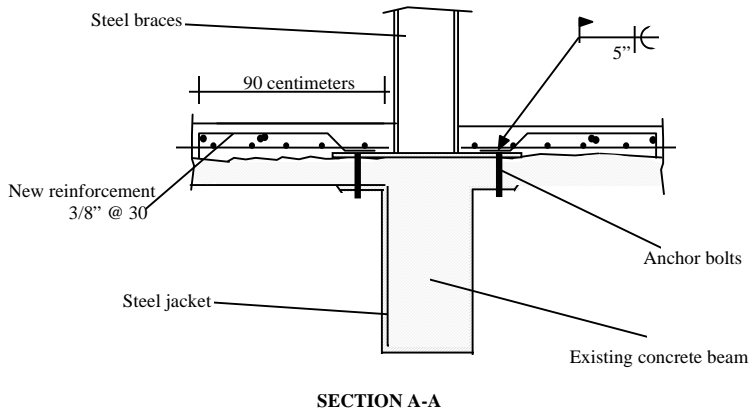
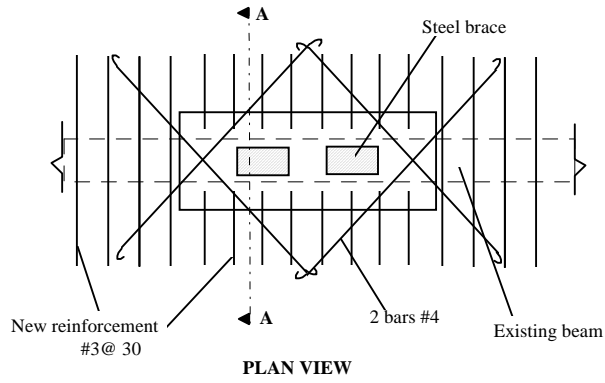

Figure 5.L11 Connection of steel braces to the existing beams.

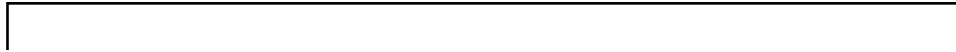

Figure 5.L12 Steel braces on line 6

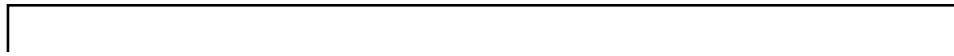

Figure 5.L13 Reinforced concrete braces on line 8.



Figure 5.L14 Brace connection on lines 6 and A.

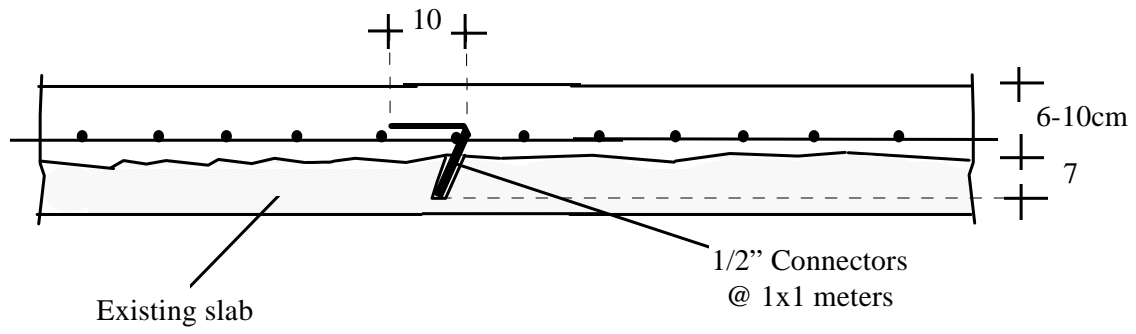

Figure 5.L15 Restoration of slabs

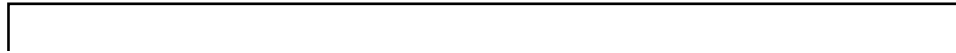

Figure 5.L16 Construction of new foundation beams.

CHAPTER 5

Comment [REO1]:

CASE STUDIES

Twelve buildings that were rehabilitated after the 1985 earthquake are presented in this chapter. The most important features of the techniques used are described, repair and strengthening details are shown in the figures. The notes and specifications included in figures were reproduced from the design drawings.

Rehabilitation of the buildings has been completed. Building description, damage during the 1985 earthquake and other previous earthquakes, and rehabilitation techniques are presented for each case study. Also, the most important aspects of the construction procedure are described where available.

5.1 BUILDING A

Building Description

The building is located in the lake bed zone of Mexico City. It was designed and constructed in 1959 and is used as a warehouse with an area of 1996 square meters per floor. The structure is located at the corner of a block and consists of a basement, ground floor, and three levels, as shown in Figs. 5.A1 and 5.A2.

The original structure consists of reinforced concrete frames in orthogonal directions. The floor system is a two-way slab. The type of foundation used was a compensated foundation. Unreinforced brick walls were used as partitions and the walls extended from top of slab to bottom of beams in the perimeter frames (column lines A and 1). No modifications to the structure had been made prior to the 1985 earthquake.

Description of Damage After the 1985 Earthquake

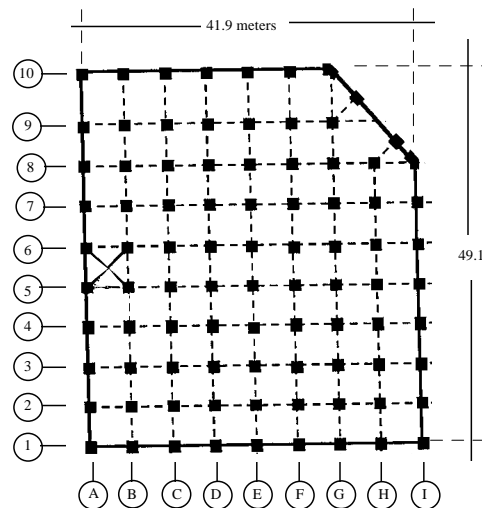

Figure 5.A1 Building plan

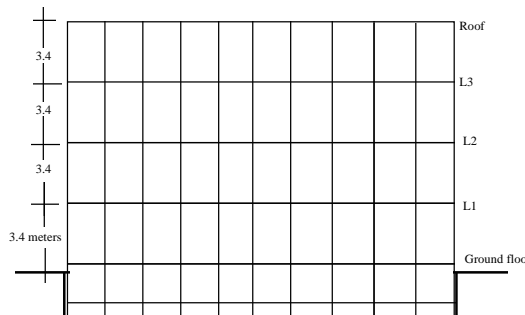

Fig. 5.A2 Building elevation.

Most of the damage due to the 1985 earthquake was concentrated in the second floor of the building. The elements that suffered most of the damage were the columns which developed cracks larger than 1 mm., suffered spalling, and some reinforcing bars were exposed and buckled and/or fractured. There was no evidence of pounding of the structure against adjacent buildings. There were no foundation failures observed but the structure had a 20 cm. tilt. There was not enough evidence to conclude that this problem was due to the earthquake.

The most damaged columns in the second floor were located at 2B and 6B (see Fig. 5.A1). These columns spalled and reinforcing bars were exposed (Figs. 5.A3 and 5.A4). Some other columns in the same floor had cracks larger than 1 mm. The damage in the second floor columns was due primarily to the restraint provided by the brick infills which produced a short column effect (Fig. 5.A5). Excessive bar splicing at the same location resulted in failure at that section (Fig. 5.A3 and 5.A4), and lack of confinement by transverse reinforcement allowed bar buckling and failure. No beam or slab damage was found.

The east facade (axes "I") suffered some minor damage but the other facade walls were cracked extensively. Some partition walls in the third and fourth floors were cracked and in some cases failed locally. The walls around the stairways suffered cracking also. The connection between the stairway concrete ramp and the floor slabs experienced extensive cracking.

Figure 5.A3 Excessive splicing of reinforcement.



Figure 5.A4 Failed column.

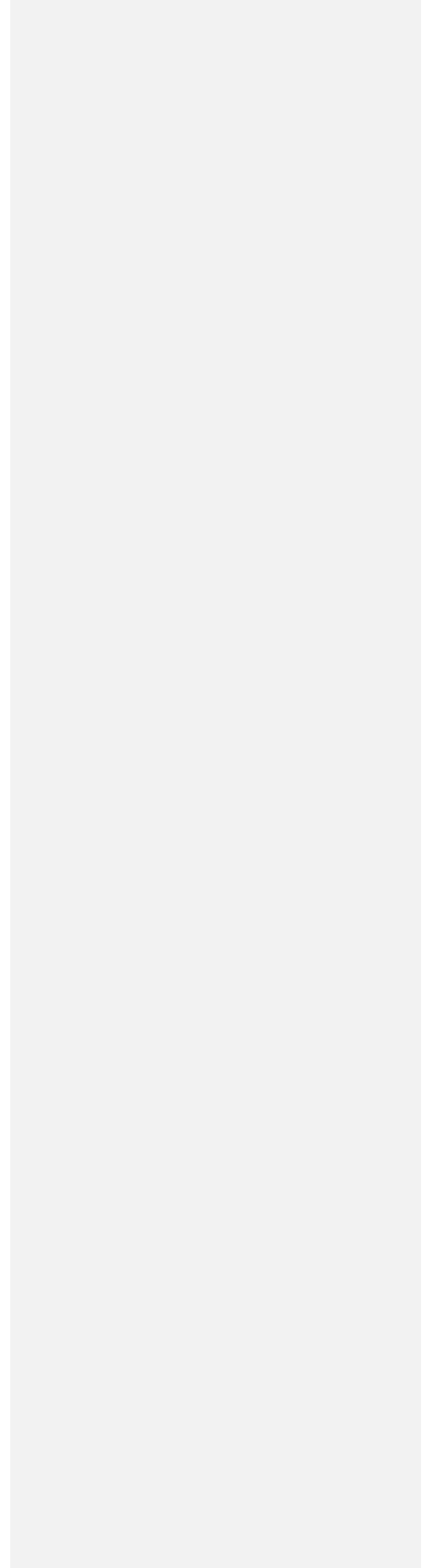

Figure 5.A5 Short column failure.

Temporary Measures

The area around the damaged columns was shored to insure stability during repair and strengthening of the damaged building. For vertical loads, two steel angles were welded longitudinally to form a closed section which was used to shore up the damaged columns. In addition, steel plates were welded to the top and bottom of the steel elements to reduce the concentration of stresses where the angles were bearing against the slab and beams. The steel columns were positioned around the damaged columns and steel side plates were welded at about the mid-height to reduce the unbraced length of the shoring elements and avoid buckling (Fig. 5.A5). No braces were used between floors.

Strengthening Procedure

Due to the observed behavior of the structure during the 1985 earthquake, it was decided to strengthen and to increase the building stiffness by completely jacketing all the beams and columns with reinforced concrete. The design of the strengthening technique was based on the 1976 Federal District Code and modifications as stipulated in the Emergency Norms. Monolithic behavior was assumed between the old and new concrete sections. The structure was idealized as plane frames running in both orthogonal directions. Static torsion effects were considered following recommendations that are included in the 1976 Code.

Columns and beams were designed to reach ultimate strength considering the more critical of the two following loading conditions:

1. Static load (Dead load + Live load) multiplied by a 1.4 load factor.
2. Static load and earthquake multiplied by a 1.1 load factor.

In addition, the capacity reduction factor used for both loading conditions was modified to 0.5 in the columns, as stipulated in the Emergency Norms.

The material properties of the original structure were:

Concrete strength	$f'c = 200 \text{ Kg/cm}^2$
Reinforcing steel	$f_y = 4200 \text{ Kg/cm}^2$

The material properties used for the repair and strengthening of the structure had the following properties:

Concrete strength	$f'c = 250 \text{ Kg/cm}^2$
Reinforcing steel	$f_y = 4200 \text{ Kg/cm}^2$
Plain #2 steel bars	$f_y = 2530 \text{ Kg/cm}^2$

The details of the additional longitudinal and transverse reinforcement in the jacket are shown in Figs. 5.A6 and 5.A7. The minimum thickness of the concrete jacket was 12 cm. The longitudinal reinforcement in the jacket was made continuous through holes drilled in the slab (Fig. 5.A7). The original column concrete surface was roughened with hand tools to provide for better stress transfer between the new and old concrete surfaces (Fig. 5.A8). The damaged columns were repaired by substituting only reinforcement that had broken and/or buckled with new steel bars that were welded to the original reinforcement at a point where it had not suffered any damage (Fig. 5.A9). The floors were shored during this operation but no attempt was made to restore original floor elevations. Because the structure had many columns which were not damaged, the floors remained in position.



Figure 5.A6 Column jacketing.

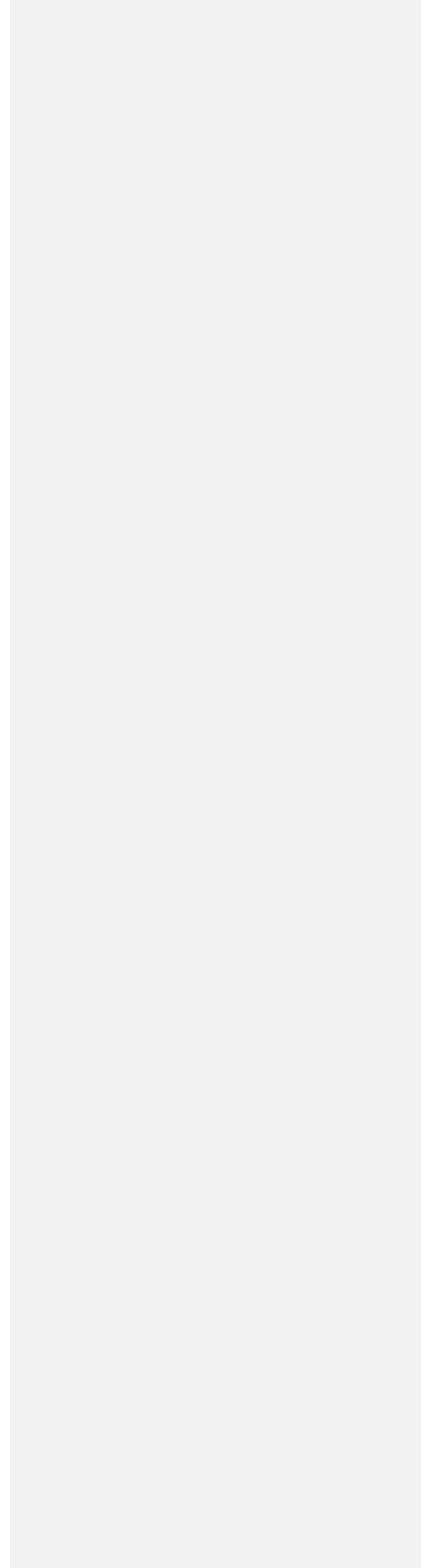



Figure 5.A 7 Continuous column reinforcement through floor.

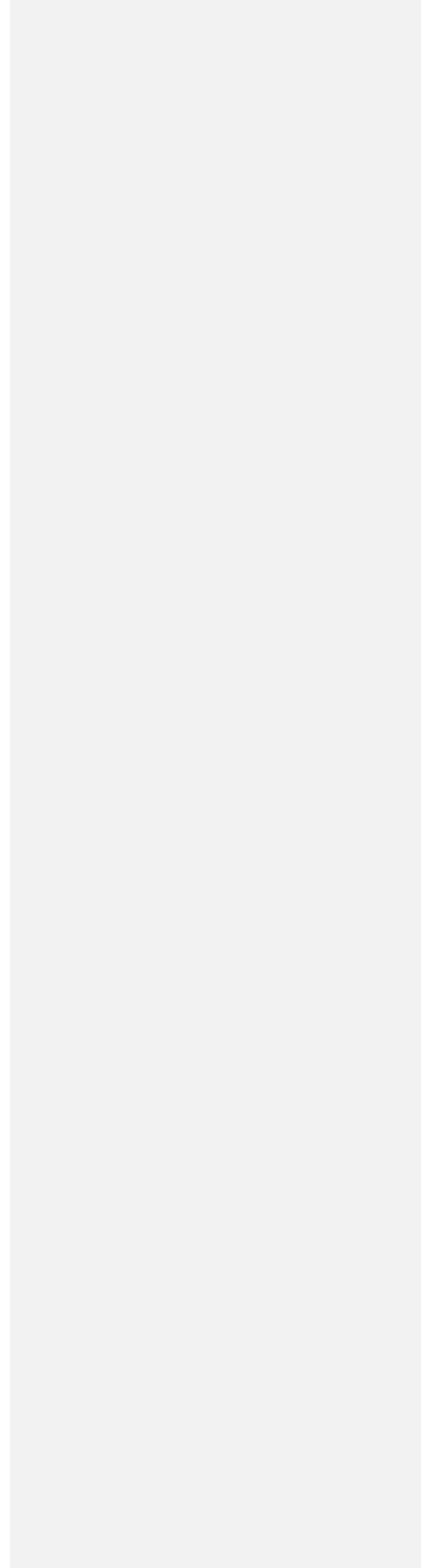



Figure 5.A8 Surface roughening and transverse reinforcement spacing.

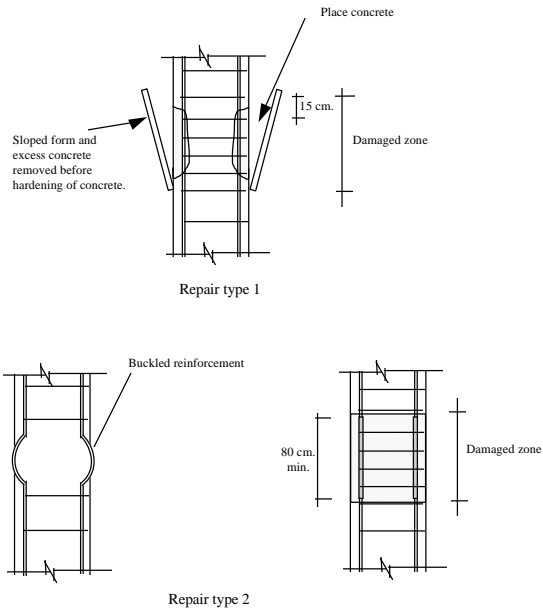
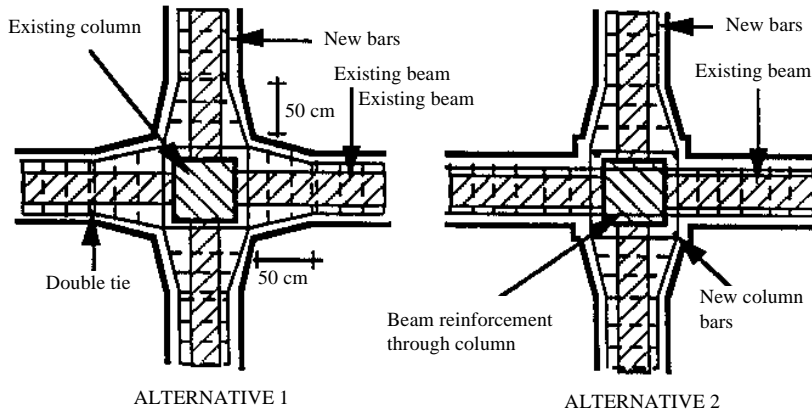

Figure 5.A9 Damaged column repair.

In the beams, additional longitudinal and transverse reinforcement was placed as shown in Fig. 5.A10. The longitudinal reinforcement was made continuous from span to span by passing the bars around the columns as can be seen in Fig. 5.A11.



Figure 5.A10 Beam Jacketing



a) 50x50 cm columns

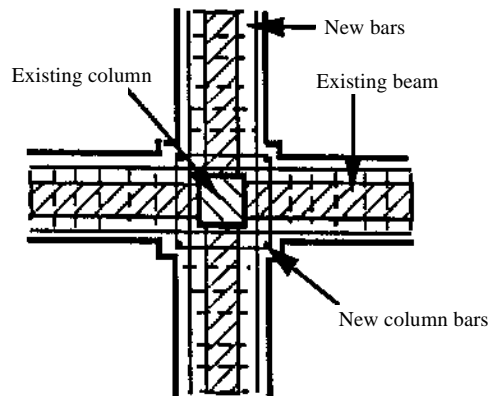

b) 30x30 cm columns

Figure 5.A11 Beam reinforcement

Additional transverse reinforcement was passed through holes drilled in the slab as shown in Fig. 5.A12. The surface preparation of the existing concrete was done in the same manner as for the columns to insure proper stress transfer between the old and new concrete (Fig. 5.A10). Additional reinforcement in the basement columns had to be anchored to the bottom of the foundation, new ties were placed through openings in the footing beams. The joint is shown in Fig. 5.A13. The general jacketing of columns did not change the load pattern in the structural system. The increase of forces on the foundation was not significant and no modifications to the footing beams were needed.

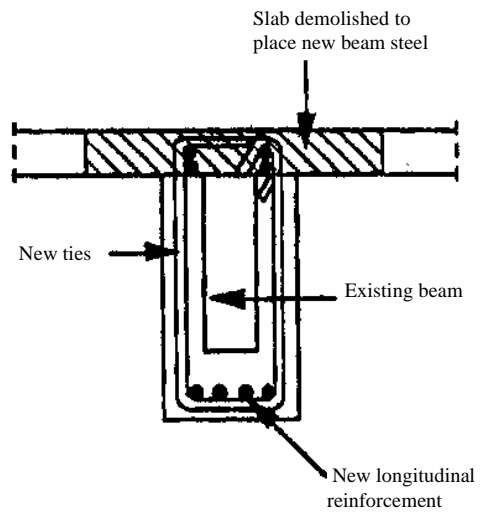

Figure 5.A12 Beam jacking.

Figure 5.A13 Opening for anchorage of column reinforcement into foundation.

The following measures were used to modify non-structural elements:

1. The masonry walls in lines 1 and A were separated from the structure to reduce the stiffness eccentricity (torsion) which they created.
2. All the brick wall partitions that had been damaged were replaced taking special care to separate them properly from the structure to avoid developing restraint that might occur when the structure deforms laterally.
3. The stairway ramps were replaced.

Construction Procedure

Modifications to the following general construction procedure were permitted but authorization of the supervisor was necessary. The general construction procedure for repair of the structure was the following:

1. The repair of the structure was to be performed by levels, starting from the basement, and proceeding upward to the fourth floor, following the recommendations below:
 - a) The ground floor was shored according to instructions from the construction supervisor.
 - b) The reinforcement in the basement columns was placed with accommodations made for placement of the reinforcement of the ground floor columns. The basement columns were cast up to the bottom face of the ground floor beams.
 - c) The reinforcement in the ground floor slab and beams was anchored to the beams and the beam reinforcement to the columns as shown in Figs. 5.A11, 5.A12, and 5.A15.
 - d) Steps a, b, and c were repeated at each floor. Shoring was to remain in at least two floors below the one that was being strengthened.

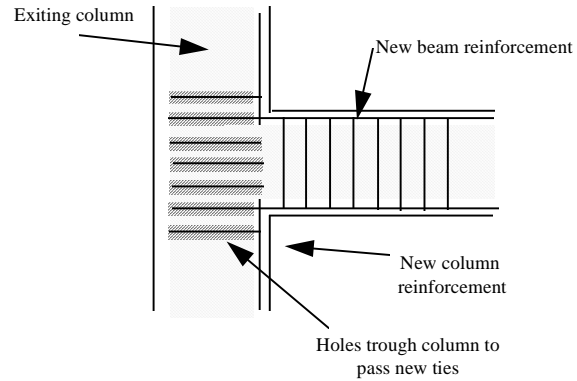

SIDE VIEW

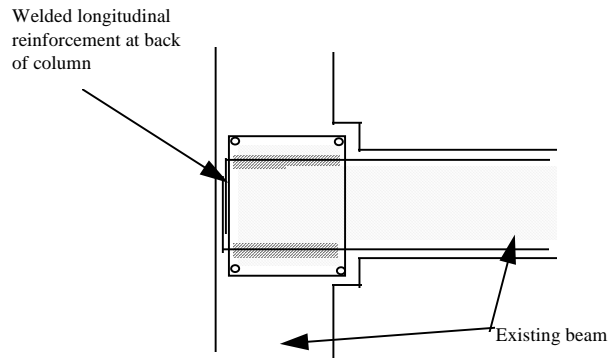

PLAN VIEW

Figure 5.A14 Beam anchorage to edge column.

2. Strengthening of the columns was performed as follows:

a) The concrete cover was removed from the faces of the columns that were being jacketed.

b) Additional reinforcement was placed and the column jacket was then cast in a single operation for the story height (Fig. 5.A6). Columns were strengthened in a story by proceeding from one area of the floor to adjacent areas, as permitted by the supervisor.

3. The following steps were followed to strengthen the beams:

a) The bottom and side face concrete cover was removed. Longitudinal and transverse slots were made in the slab and on top of the original beam to place the additional longitudinal and transverse reinforcement.

b) The reinforcement of the jacket was then placed and concrete was cast through the holes in the slab. Beams were cast in two steps, in the first stage the region at and near the column-beam joints were cast and a second placement completed the middle portion of the span.

4. The general procedures that were followed to strengthen the slab were:

a) All floor coverings were removed and the concrete cover was demolished until the slab top bars were exposed over the entire floor area.

b) The additional reinforcement was placed according to the corresponding details and the concrete cover was recast. The concrete mix was fabricated using additives that would enhance bond between new and old concrete surfaces.

5. In all the cases mentioned above, the surface between new and old concrete was prepared as follows:

a) The existing concrete was chipped, scrubbed with a special brush and high pressure water, and cleaned to remove loose particles left from the chipping process.

b) The existing concrete surface was moistened at least 6 hours before casting new concrete.

c) A volume stabilizing additive was included in the concrete to reduce volume change.

5.2 BUILDING B

Building Description

This building was designed and constructed towards the end of the 1960's under the 1966 Mexico City Building Code. According to this code, the seismic base shear coefficient that corresponded to the site and type of structure was $C=0.06$.

The structure is located in the lake bed zone of Mexico City. The water table is located 1.80 m. below the ground surface. The surface formation consists of a sandy silt with low compressibility and an average water content of 100%. The clay formation beneath is 24.0 m. thick with an average water content of 300%. The stratum of soil known as the first hard layer, where point bearing pile foundations for most of the

buildings are supported, is located at an average depth of 32.0 m. and is 3.0 m. thick, with an average water content of 50% (semi-compact silt).

The building is regular in plan, consisting of three bays in both of the orthogonal directions. In the E-W direction, the building has two edge bays with a 4.45 m. width, and the middle bay is 5.60 m. wide. In the N-S direction, the three bays have the following dimensions: 5.10 m. between column lines 1 and 2, 5.30 m. between 2 and 3, and 5.10 m. between 3 and 4.

In elevation, the building has 11 floors with a floor height of 3.00 m. for the first floor and 2.60 m. for the upper floors. The waffle slab floor system is 40 cm. thick at the first level and 30 cm. thick at the upper levels. Fig. 5.B1 shows the building plan and elevation.

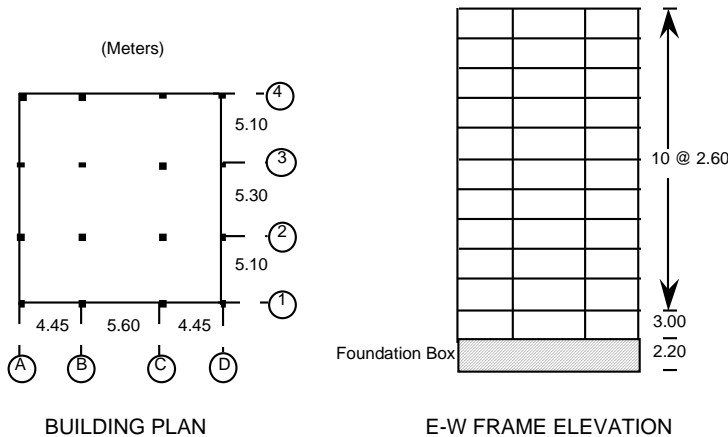

Figure 5.B1 Typical plan and elevation of building B.

The building rests on a partially compensated foundation that is 2.2 m. deep. The box is supported by friction bearing piles driven to a 27.0 m. depth. The building superstructure consists of a reinforced concrete waffle slab on rectangular columns. A common construction practice in Mexico City used in this building consists of forming ribs of the waffle slab with sand-cement blocks to reduce the weight of the floor system and leaving the blocks embedded in the waffle slab after casting.

The properties of the structural components of the building were evaluated so that the fundamental period of vibration of the structure could be computed, as well as displacements and stresses applying loads as specified by the 1985 Mexico City Emergency Norms. The results of the analysis showed that the fundamental periods of the building were 2.55 sec. and 2.65 sec. for the E-W and N-S directions respectively.

These periods are close to the natural period of the soil in this zone, which is around 2.0 sec [Lermo,1988]. Large deformations would be expected in an earthquake and the type of damage that was observed in the non-structural elements of the structure after the 1985 Mexico Earthquake confirm this expectation.

Description of Damage After the 1985 Earthquake

After the 1985 Mexico Earthquake it was observed that the building experienced damage in the non-structural partition walls due to large lateral displacements of the structure. There was no evidence of overall structural distress, since no settlements or loss of plumb were detected in the building. Also, the foundation slab and grade beams appeared to be in good condition after the earthquake.

It can be concluded from the damage observed after the earthquake, as well as from the analysis of the structure, that the structure was flexible under the action of lateral loads. Therefore the retrofitting scheme chosen had to deal primarily with eliminating the structural flexibility without creating additional problems that were non-existent prior to the repair of the structure.

Strengthening Procedure

Once the damage of the non-structural partition walls was detected and after the analysis was performed, the decision was made to stiffen the structure and to modify the foundation.

Diagonal steel bracing in the middle bays of the exterior frames was originally proposed but the scheme was not satisfactory because large axial forces were induced in the foundation, and would have required the addition of a large number of piles which rendered the solution impractical. The decision was made to provide steel diagonals and beams, as horizontal collector elements, on the four facades of the structure. The use of diagonals across the entire exterior width provided a better solution because the larger distance between the ends of the braced frame reduced the forces transmitted to the foundation and, therefore the number of piles that had to be added. This solution was feasible since there was enough space between the exterior frames and the property line, without interference from adjacent construction to permit installation of the bracing and the piles.

Figure 5.B2 shows the layout of the diagonal bracing on the building facades. The curtain walls had to be removed in order to connect the braces to the original structure. Figure 5.B3 shows the facade removed from the building during the repair.

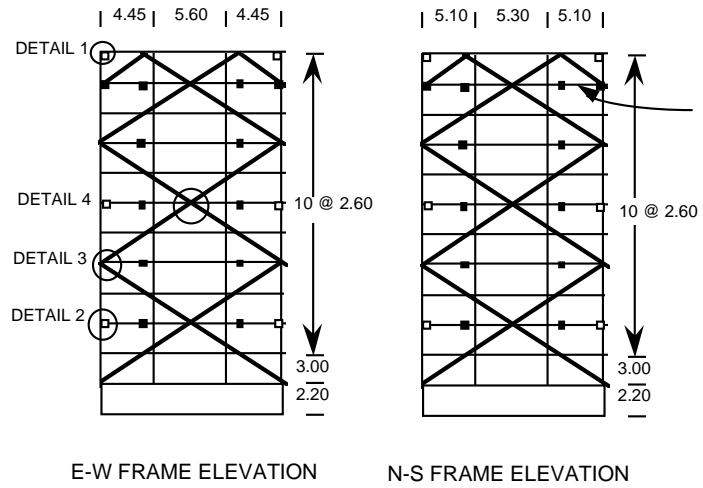

Figure 5.B2 Arrangement of bracing system.

Figure 5.B3 Facade removal.

With the advice of geotechnical engineers, three friction piles were added at each corner column, for a total of 12 piles for the entire building which were driven to a depth of 27.0 m. A 50 cm. borehole was excavated in the basement prior to driving the piles to insure their verticality. Figure 5.B4 shows the pile distribution in the building plan.

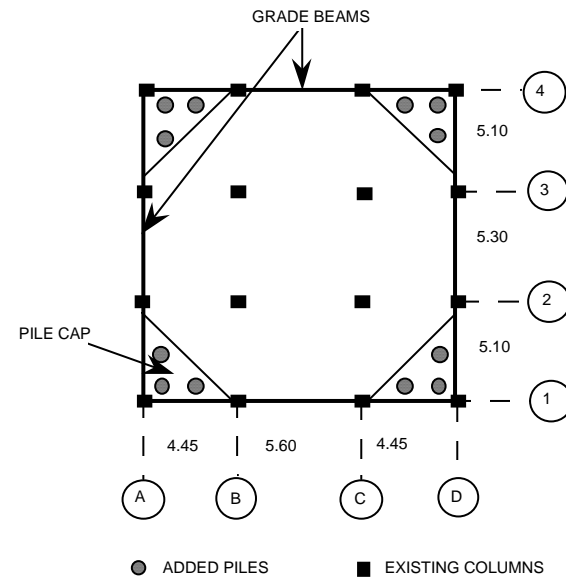
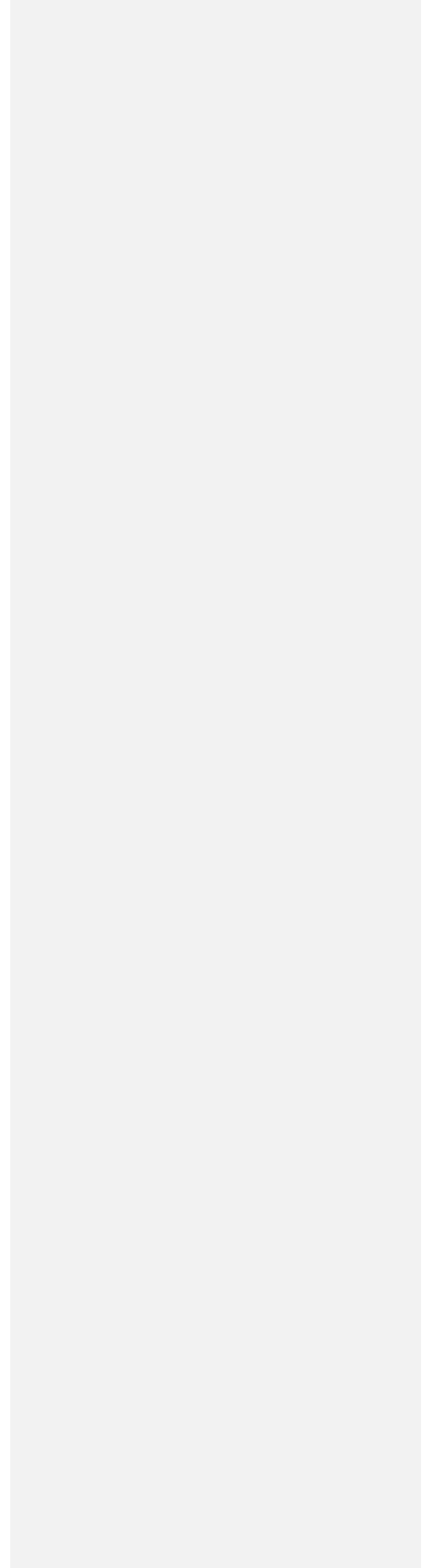

Figure 5.B4 Foundation plan.

Four perimeter grade beams were added adjacent to the existing beams and connected to the corner pile cap. One of the grade beams is shown in Figure 5.B5. Triangular pile caps were used at the four corners of the building, to transfer the vertical compressive and tensile forces that are generated at the base of the bracing system to the piles. An opening was cast into the pile cap for driving the pile through the cap. The opening had a square truncated pyramidal shape so that the forces could be transmitted from the pile cap to the piles by friction and wedge action. Figure 5.B6 shows the pile cap and the details of its connection to the piles at each building corner is shown in Figure 5.B7.

Figure 5.B5 Grade beam.

Figure 5.B6 Pile cap.



Since the length available to drive the piles was limited, the piles were constructed in several segments and after one was driven, another segment was connected and the driving procedure continued. Pile segments are shown in Fig. 5.B8. The segment lengths and reinforcement varied as shown in Fig. 5.B9. The pile segments were post-tensioned to provide continuity. Four 1/2" prestressing strands were used for each pile.

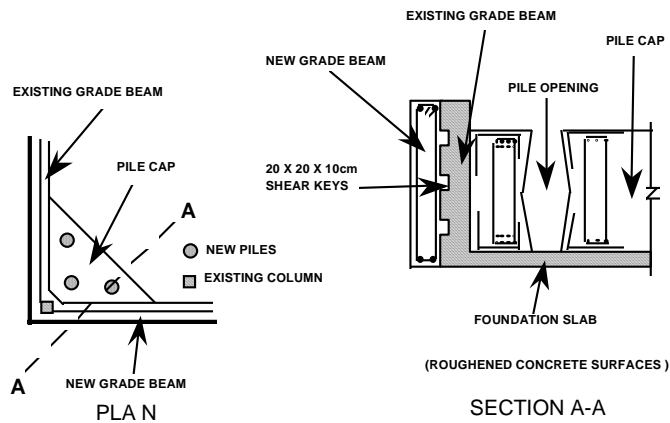

Figure 5.B7 Pile cap detail plan.

Figure 5.B8 Pile segments.

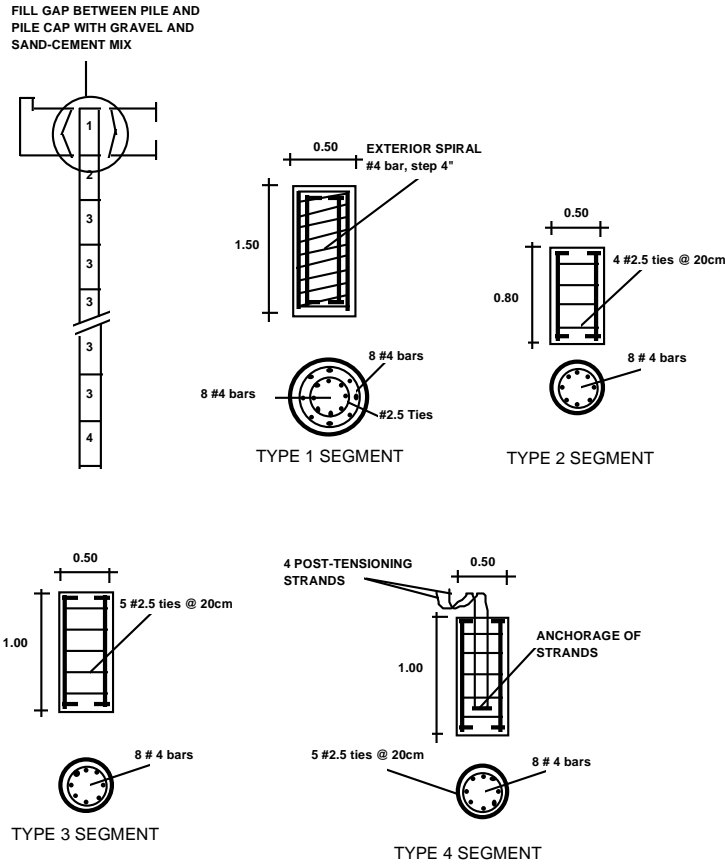

Figure 5.B9 Types of pile segments.

After the piles were driven, the space left between the pile and the pile cap was filled with 3/4" gravel and injected with a sand-cement mix to provide continuity between the elements (see construction procedure).

The columns in the exterior frames (where the bracing system was connected) were strengthened by adding four steel angles on the corners of each column and welding steel straps at 30 cm spacings to the angles to improve the axial capacity of the columns and to improve confinement of the column section. A detail of this procedure is illustrated in Fig. 5.B10.

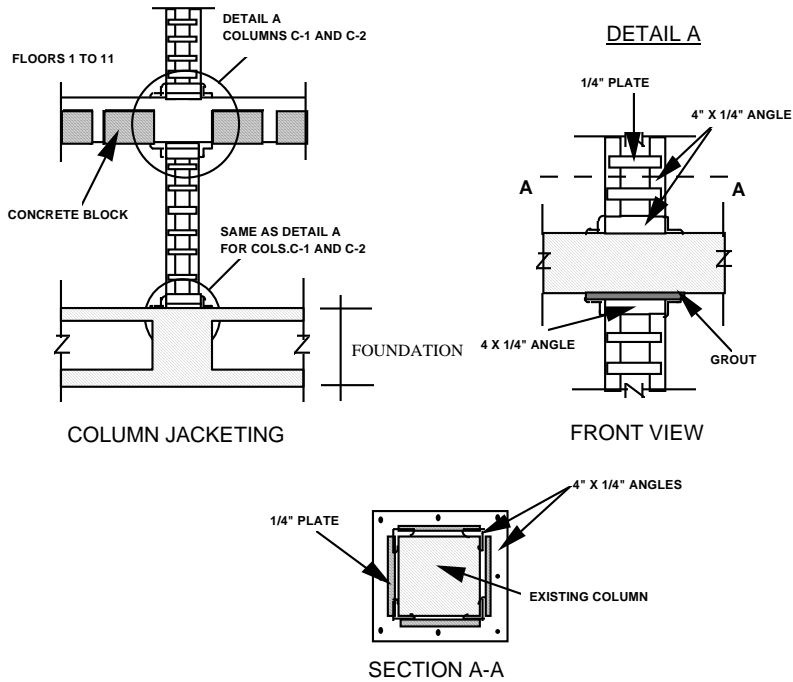

Figure 5.B10 Strengthening of C1 and C2 columns.

The procedures used to strengthen the columns varied with the position of each column in the building plan. For the interior columns of the perimeter frames, strengthening was only performed for the first six floors, whereas for the corner columns (C3), steel elements had to be added along the complete height of the building in order to connect the steel diagonals and beams. Fig. 5.B11 shows the different types of columns in the plan of the building.

The steel diagonals were connected to the new grade beams and to the superstructure slabs and columns as shown in Figures 5.B12 to 5.B18 so

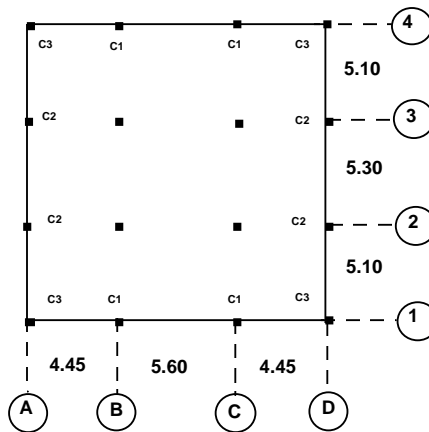

Figure 5.B11 Column location.

that the two systems worked together under lateral loading. The location of the details is indicated in Fig. 5.B2. The diagonals and the collectors were welded to plates that in turn were welded to the corner column angles (Fig. 5.B12). The connections of the bracing and collector elements to the waffle slab were performed by welding the base plates to partial steel jacketing of spandrel ribs (Fig. 5.B13).

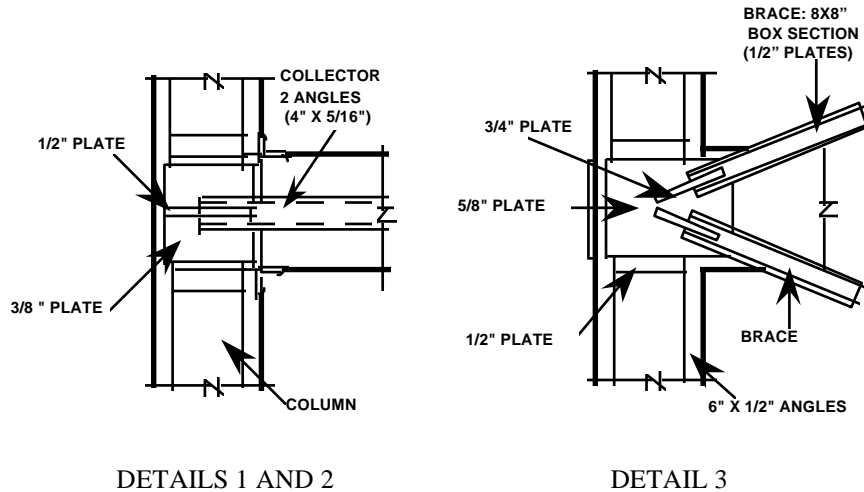

Figure 5.B12 Connections of bracing system.

The materials used for the strengthening system were as follows:

Pile concrete $f'_c=250 \text{ Kg/m}^2$ Pile reinforcement $f_y=4200 \text{ kg/ m}^2$
 Post tensioning steel (piles) $f_y=15000 \text{ Kg/ m}^2$
 Bracing system : A-36 steel

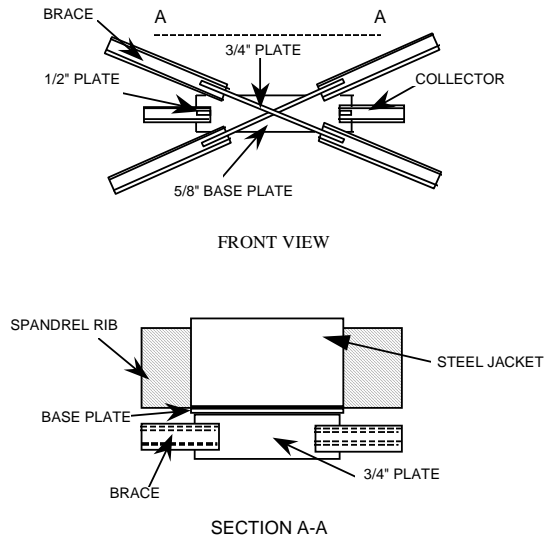

Figure 5.B13 Connection of bracing system to waffle slab.

The retrofitting scheme was chosen to achieve the following goals:

1. The bracing system was to be stiffer than the frame and assumed to carry all the horizontal force.
2. The fundamental structural periods in both directions were reduced to 1.0 sec. to eliminate the problem of resonance.
3. The story drift ratio was reduced to values lower than 0.006, and
4. The stresses in the interior frames were reduced.

Figure 5.B14 Connection in corner column.

Figure 5.B15 Connection of collector elements.

Figure 5.B16 Connection at intersection of braces.

Figure 5.B17 Bracing system.

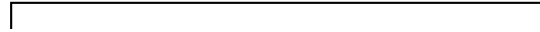

Figure 5.B18 Bracing system.

Construction Procedure

The general construction procedure for repair of the structure was the following:

1. Construct pile caps and perimeter grade beams (leaving anchors as indicated in plans to attach the pile driving frame).
2. Drive piles in segments.
3. Before removing the driving jacks, the voids between the pile cap and the piles must be filled with 3/4" gravel and a mortar injection tube must be left in place.
4. Remove driving jacks.
5. Post-tension two interior pile cables to 50 ton/pile.

6. Before fabricating the bracing elements, exact building dimensions should be determined at the site.

7. The braces should be placed symmetrically around the building during construction to avoid creating torsion in the building if a seismic event should occur during this period.

8. Proper connection between the bracing system and the existing concrete structure should be verified for the two systems to work together adequately.

5.3 BUILDING C

Building Description

The building is located in the lake bed zone of Mexico City and it was used as a medical office. It is a long narrow building (1 bay by 6 bays) with an area approximately 335 m² per floor (Fig. 5.C1). In elevation, the building consisted of twelve upper floors with a story height of 2.95 m., and a first story of 3.50 m. (Fig. 5.C3).

Two reinforced concrete perimeter frames provided lateral capacity in the long direction. These frames have deep beams that extended above and below the slab in each floor with the remaining space left for windows. The beams had a 60 cm. projection below the slab and 80 cm. above. The deep beams are supported on 1.73 m long channel shaped columns. The column flanges are 15 x 45 cm. in cross sectional dimensions and the column web is 1.43 m long with varying thickness from 15 cm at center to 25 cm at the flange connection (Fig. 5.C2)..

Concrete shear walls, located in column lines 1 and 7 respectively, provide most of the lateral capacity in the short direction of the building. Additional structural walls around the elevator core are located between column lines 3 and 5 (Fig. 5.C1). All the reinforced concrete walls are 15 cm. thick.

The floor system is a reinforced concrete slab supported on truss girders spanning in the short direction of the building. These are supported by the perimeter frames that were described above. The slab is 8 cm. thick.

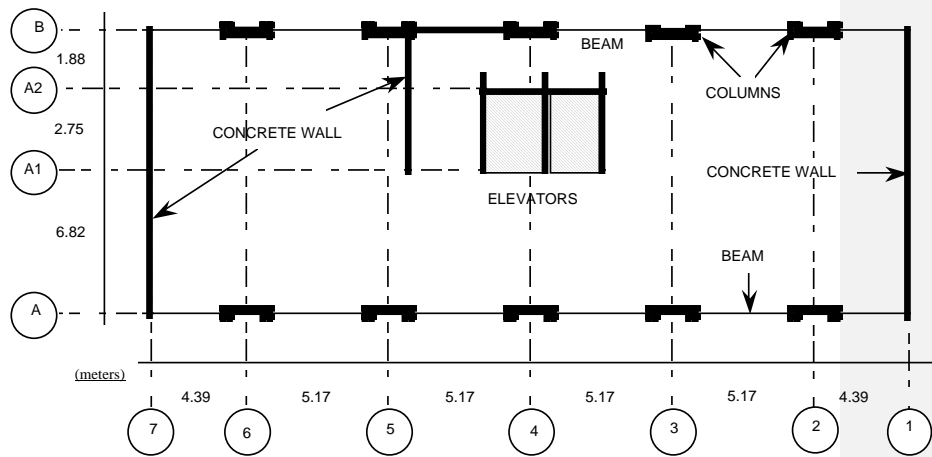

Figure 5.C1 Typical plan.

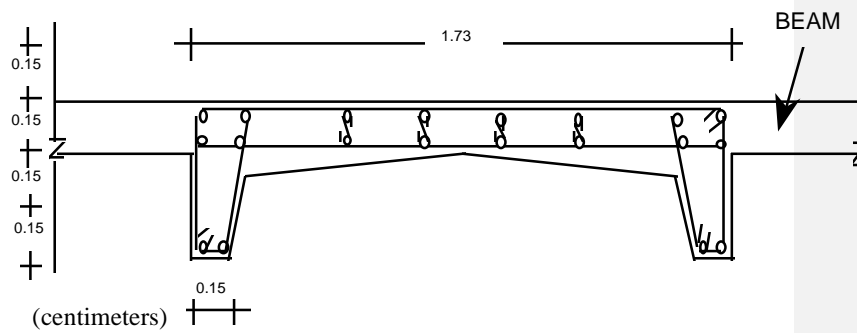

Figure 5.C2 Existing column.

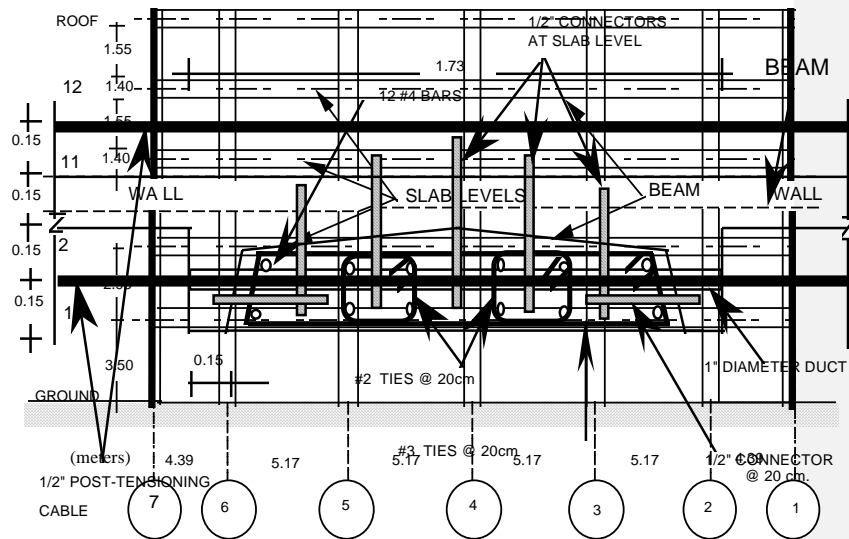

Figure 5.C4 Column strengthening.
Figure 5.C3 Building elevation.

The building rests on a partially compensated foundation box that is supported on friction piles. The foundation box is approximately 2.00 m. deep and is bounded by perimeter retaining walls.

Description of Damage After the 1985 Earthquake

After the 1985 Mexico City Earthquake, the reinforced concrete beams in the perimeter frames showed moderate to severe cracking. It was considered that the damage was not significant enough to require any temporary shoring measures.

Strengthening Procedure

It was decided to reduce the building mass by removing the four top floors. Furthermore, the retrofitting approach included strengthening of the frames in the long direction by post-tensioning the deep beams, in the first five floors, and upgrading columns in all the stories.

The column capacity was increased by infilling the channel column cross section to form rectangular sections and providing additional reinforcement. To develop good shear transfer between the new and old column sections, epoxy grouted dowels were used to connect the new and old column sections, and the new column section to the slab at the floor levels. Details of the column strengthening are shown in Figure 5.C4.

All of the cracked structural elements were injected with epoxy. Heavily cracked beams were repaired by removing the damaged concrete, adding ties, and recasting a new concrete section. Adequate bond between the new and old concrete surfaces was achieved by cleaning debris from the old concrete surfaces, saturating the surfaces, and using additives to control volume contraction in the new concrete.

The material properties proposed for the retrofitted structure were the following:

Concrete	$f'_c=250 \text{ Kg/cm}^2$
Steel reinforcement	$f_y=4200 \text{ Kg/cm}^2$

The deep beams in the perimeter frames were post-tensioned to increase their shear capacity in the first five floors. This was done by using two 1/2" post-tensioning cables that parallel the beams and are anchored at the shear walls on lines 1 and 7 that run in the perpendicular direction. The cable position can be seen in Figures 5.C4 and 5.C5. The cables were placed symmetrically, on the inside and outside the building, and below and above the floor slabs to avoid creating any bending stresses on the perimeter frames due to the post-tensioning. The exterior cables were installed inside a 1" diameter duct that passes through the frame columns. The interior cables lie below the truss girders that span in the perpendicular direction.

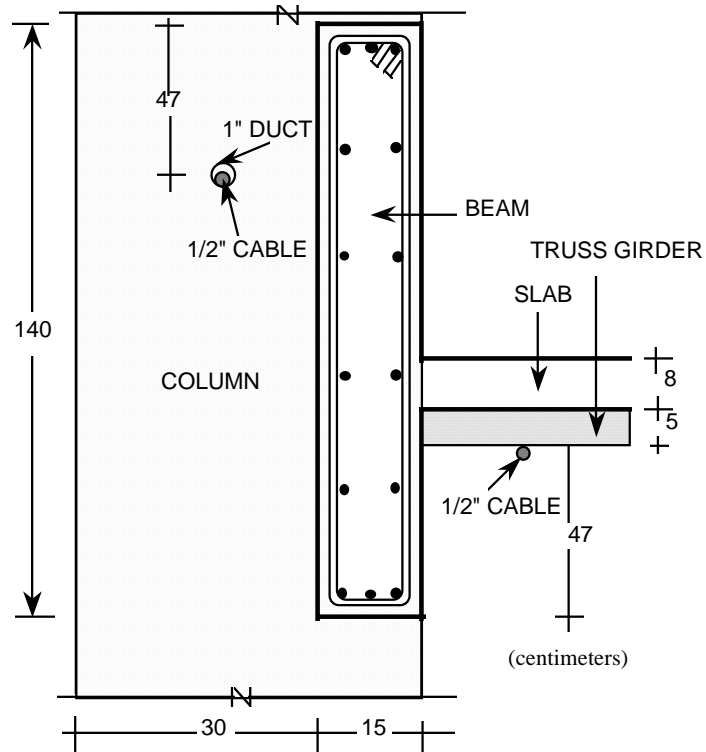

Figure 5.C5 Cable location.

The structural walls located on column lines 1 and 7 were strengthened by adding new boundary columns. The post-tensioned beam cables were anchored at the boundary elements. Details of the wall boundary elements are shown in Figures 5.C6 and 5.C7. Three of the four columns were constructed on the exterior of the building, and the fourth one, at B-7, had to be constructed inside the building due to limitations imposed by the property line.

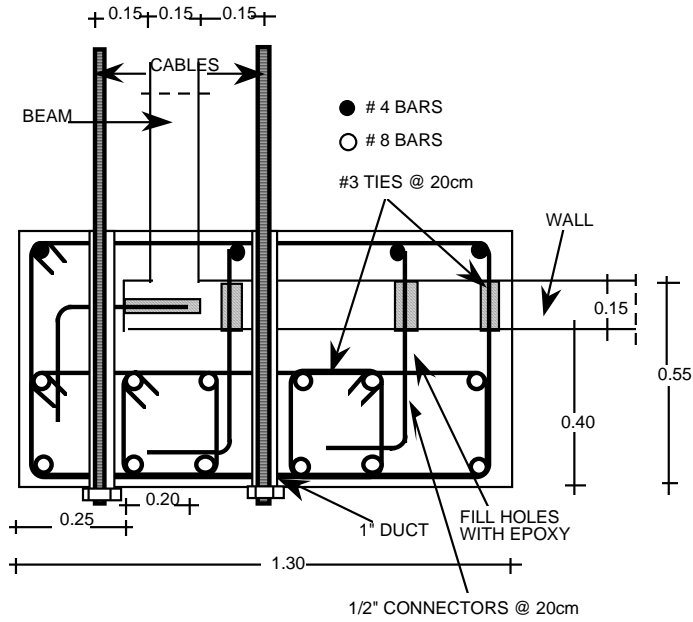

Figure 5.C6 Anchorage of cables, columns B-1,A-1,A-7.

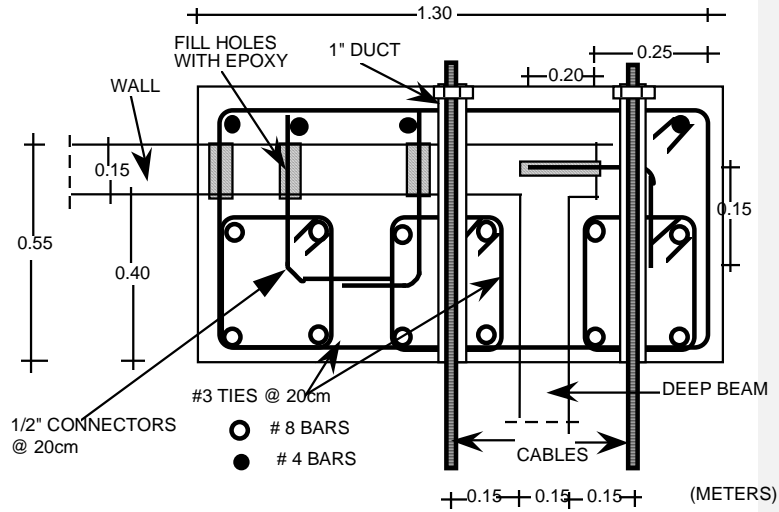

Figure 5.C7 Anchorage of cables, column location B-7.

It is important to note that the duct for the post-tensioning cables passed through the strengthened columns as well as the new columns.

The reinforced concrete infill walls on line B, between lines 4 and 5, were not connected to the structure at the base of each wall. The walls had a 60 cm opening in all stories which had to be infilled, as shown in Figure 5.C8, to transfer forces to the base.

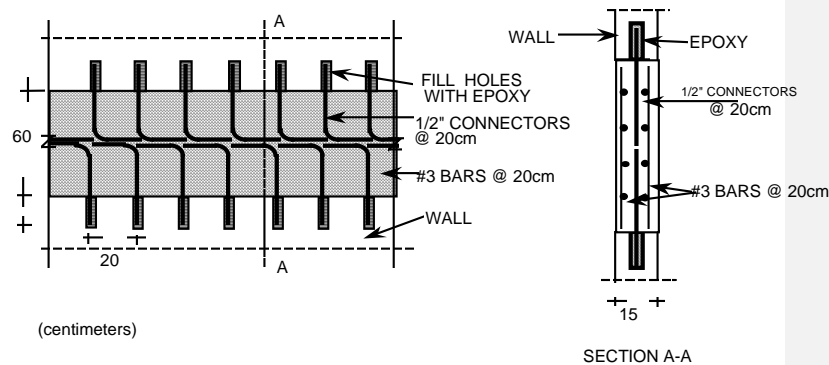

Figure 5.C8 Gap infill in reinforced concrete wall.

To connect the channel strengthened columns to the foundation, column stub sections were constructed inside the foundation box and connected to the columns on the outside by ties that passed through holes drilled into the foundation walls. The stub columns ended at the foundation slab level. It was assumed that the foundation beams can transfer any additional column forces to the pile caps, as shown in Figure 5.C9.

The new boundary columns at the end walls were also continued into the foundation box. They were connected to foundation beams with a system similar to the one used for the strengthened columns.

The building, after retrofitting, is shown in Figures 5.C10 and 5.C11.

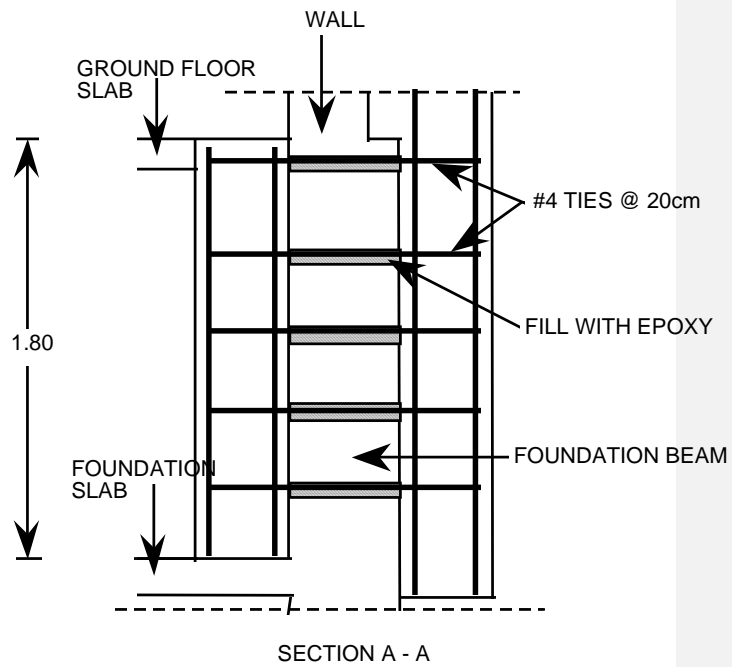
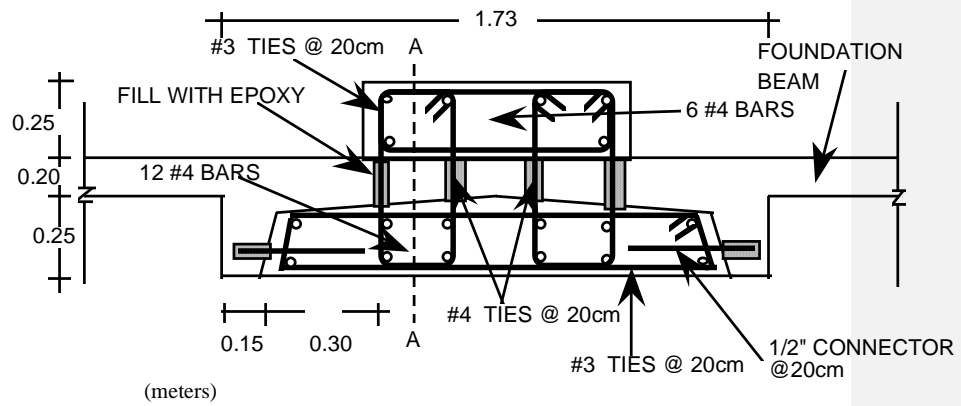
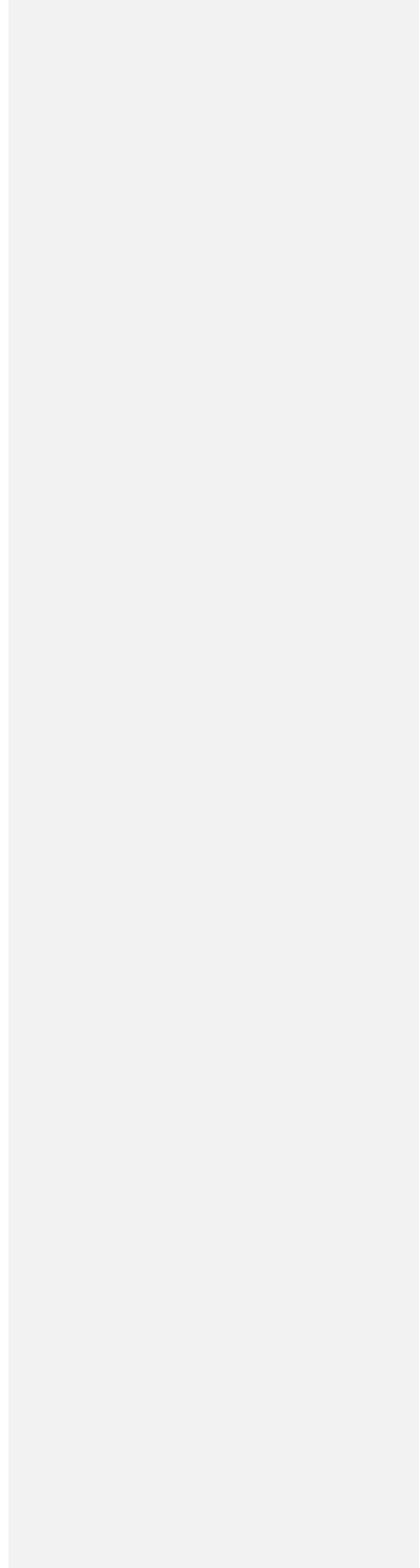

Figure 5.C9 Connection column strengthening to foundation.

Figure 5.C10 Retrofitted building.

Figure 5.C11 Post-tension cable anchorage.



5.5 BUILDING E

Building Description

The building is located in the lake bed zone of Mexico City. The structure was constructed in 1979 and is used as an apartment building. It has an area of approximately 215 m² per floor. The structure has a "C" shape in plan, and consists of two apartment units separated by the stairs and elevator core (Fig. 5.E1. The North unit has seven stories, and the South unit has eight stories plus a machine room (Fig. 5.E2).

At the first floor and the roof, the structure is a waffle slab supported on reinforced concrete columns. At all other levels, the slab is a beam-block floor system.

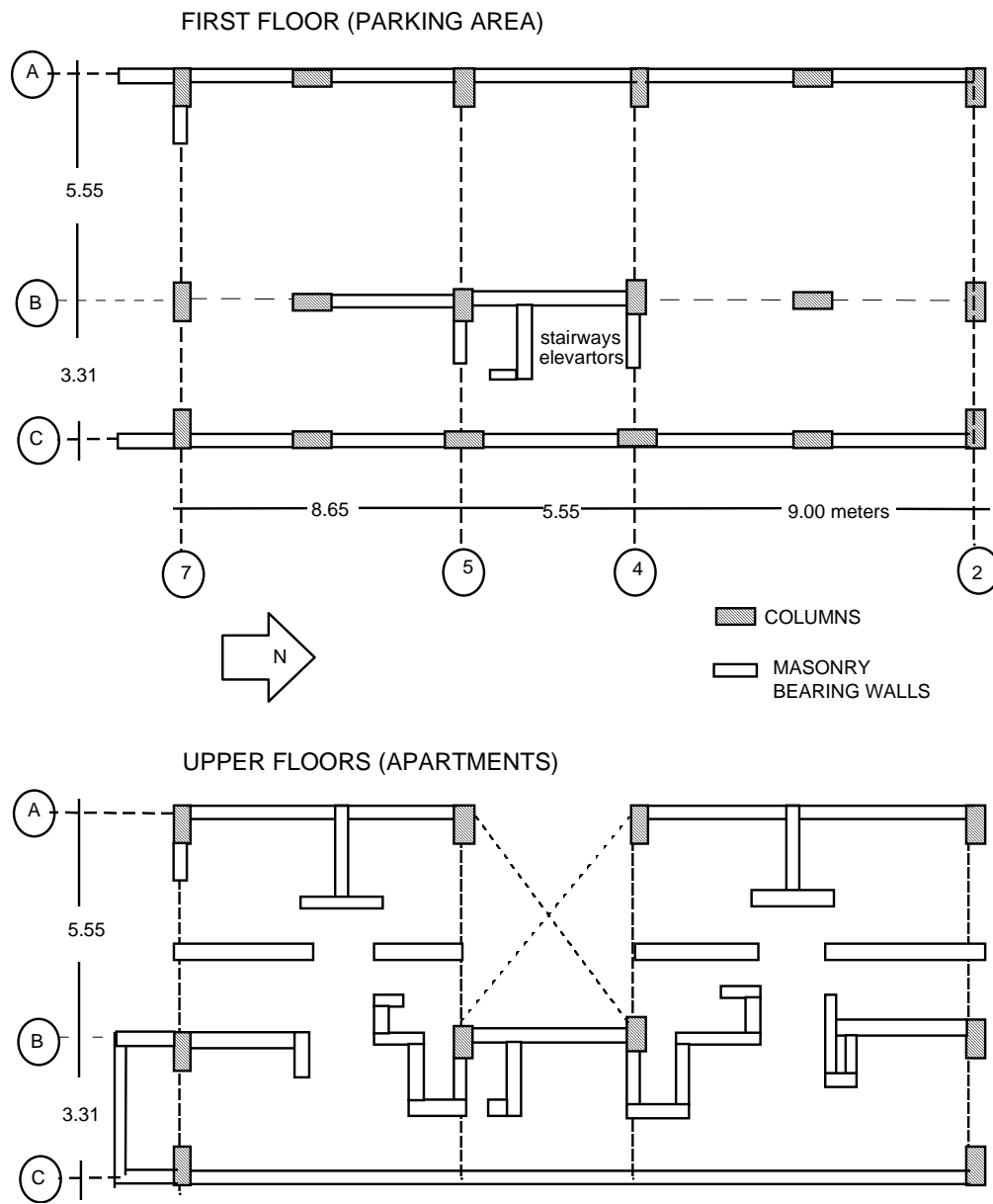

Figure 5.E1 Building plan.

supported on masonry walls confined by rectangular reinforced concrete boundary elements. These walls are supported on the waffle slab and columns. As a result, the first level is a soft story. The foundation consists of a grid and slab system on friction piles.

Description of Damage After the 1985 Earthquake

Damage was concentrated in the masonry walls on all levels. The damage was worse in the E-W direction. There was no damage to the foundation, columns or slabs, and no pounding with adjacent buildings was evident. Plan, as well as vertical, irregularities and lack of lateral load bearing capacity of the masonry walls in the short direction were the principal causes of damage.

Most of the E-W walls had diagonal cracks and lost plaster cover. The boundary elements of these walls also presented cracking and loss of concrete cover, with exposed reinforcement (Fig. 5.E3). Some others completely collapsed. The walls around the stairs and elevator core had severe cracking in all levels.

Figure 5.E4 shows the exterior wall on line A, which developed local failure due to the movement of the framing perpendicular wall. The rest of the walls in the N-S

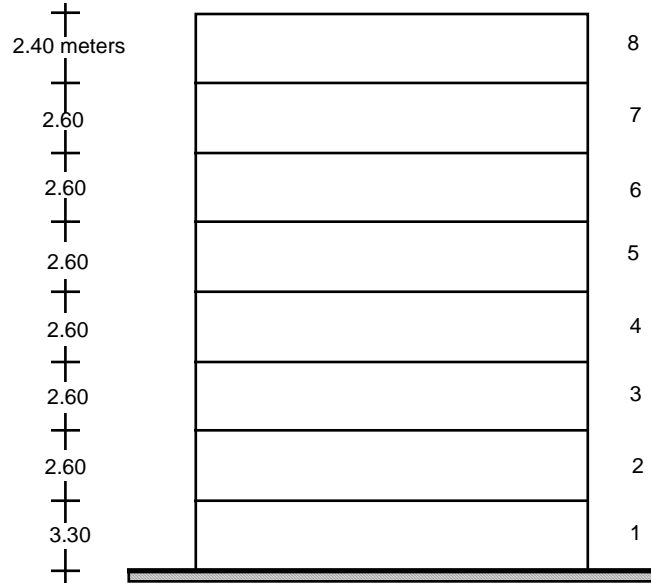

Figure 5.E2 Building elevation.

Figure 5.E3 Damage in walls.

direction did not present any damage. This direction has considerably larger strength than the short direction, due to the massive continuous boundary walls on lines A and C (Figure 5.E1).

Figure 5.E4 Damage in exterior wall on line A.

Temporary Measures

The damaged structure was shored with steel and wood elements. In the ground floor, steel frames with tubular braces were used to shore the waffle slab. Wood beams were placed at the top of the steel shores to distribute the loads to the supporting slab (Fig. 5.E5).

Figure 5.E5 Ground floor shoring.

Braced wood frames were used as shoring in upper stories. Two wood elements connected with wire formed the frames (Fig. 5.E6 and 5.E7). This bracing was placed only in the E-W direction, without any attention to their distribution in plan.

Figure 5.E6 Shoring with wood elements in upper floors.

Figure 5.E7 Shoring details.

Strengthening Procedure

To strengthen the structure in the short direction (E-W), four reinforced concrete frames were added on lines 2, 4, 5 and 7, Figure 5.E8 shows the layout of the new elements. The existing beams and columns were partially demolished then upgraded with larger sections and reinforcement.

Figure 5.E9 shows a detail of a new beam and the facade balcony which was enlarged along line 7. Pictures of the construction of the new frames are shown in Figures 5.E10 and 5.E11. A section of the floor system adjacent to the frames was also removed. The existing slab reinforcement was left in place. This reinforcement was anchored in the new concrete beams and columns, as indicated in Figures 5.E12 and 5.E13.

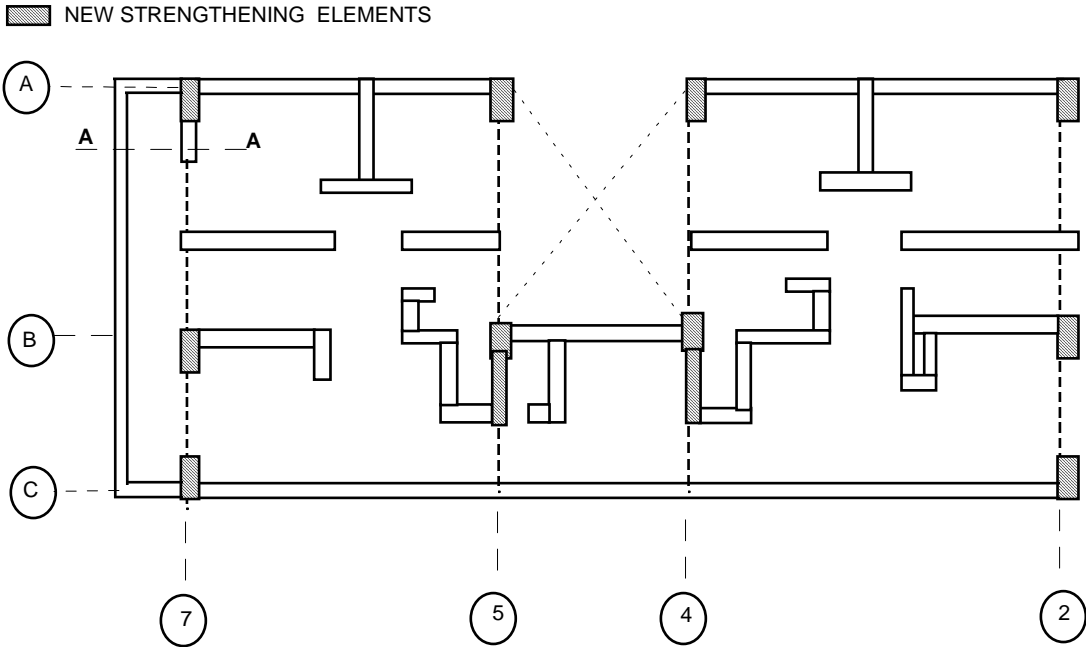
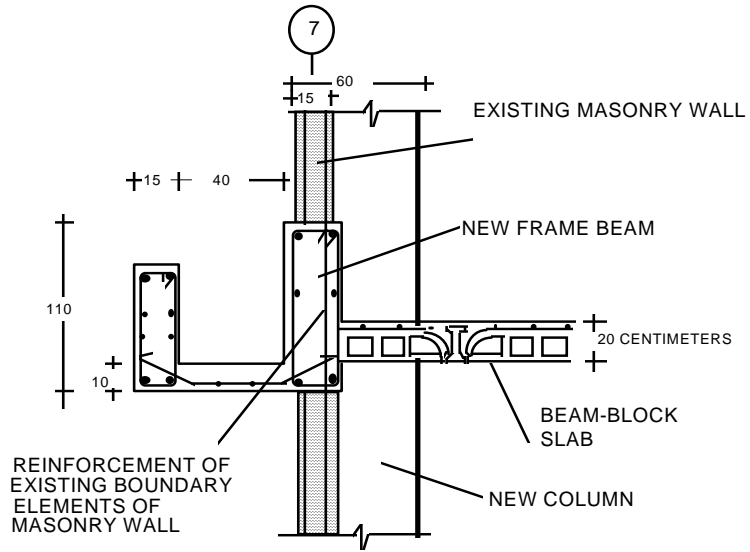

Figure 5.E8 Strengthening scheme.



SECTION A-A (From Fig. 4.53)

Figure 5.E9 Detail of new beam in frame 7.

Figure 5.E10 Exterior reinforced concrete frame.

Figure 5.E11 Detail of reinforced concrete frame.

Figure 5.E12 Connection of new reinforced concrete frame.

Two reinforced concrete walls, 15 cm thick and continuous over the height of the building, were built around the stairs and elevator area on lines 4 and 5 (Fig. 5.E14). The walls were connected to new columns B-4 and B-5 (see Fig. 5.E8). Parts of the foundation slab and foundation beams were removed to anchor the reinforcement of the new columns and walls. These details are presented in Figures 5.E15 and 5.E16. According to the design drawings, the rest of the foundation was not modified since the analysis showed it was adequate to support the new load path.

All the damaged masonry walls were repaired with wire mesh and shotcrete on both sides (Fig. 5.E17). In the N-S direction, new reinforced concrete beams were built in upper floors on boundary line A, between lines 4 and 5, to connect the two units of the original structure and reduce the torsional effects on the building. The new beams have a 20X30 cm section. These elements may act as weak coupling beams but may be insufficient to link the stiff boundary masonry walls on line A. The new beams can be seen in Figure 5.E18.

Figure 5.E13 Connection of new reinforced concrete frame.

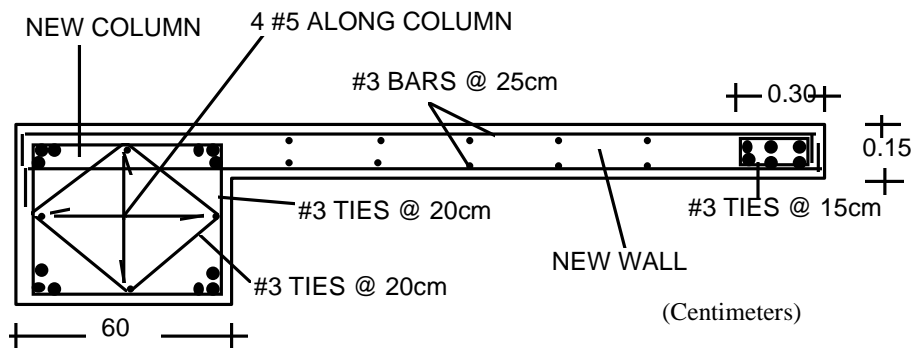
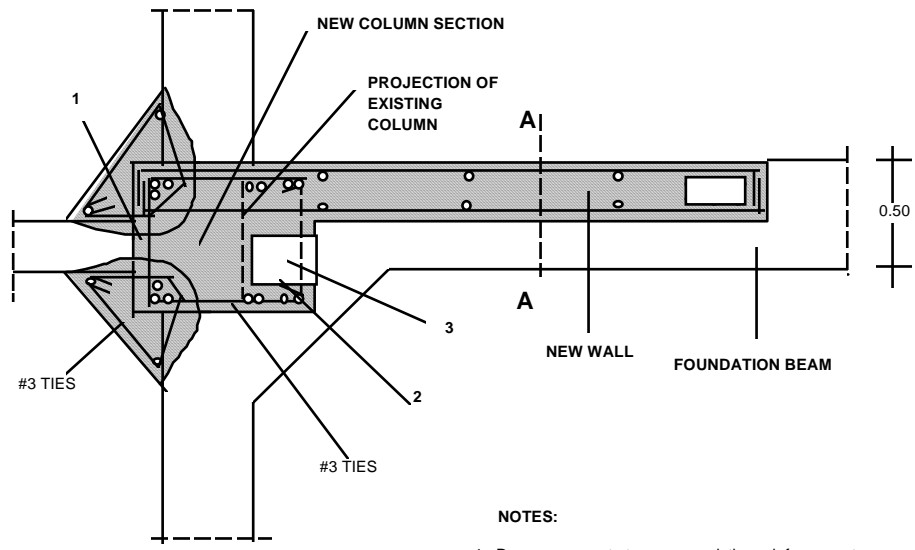

Figure 5.E14 Reinforcement details of new concrete walls.



PLAN

NOTES:

1. Remove concrete to expose existing reinforcement. Cast concrete with additive to control volume changes. Surfaces must be cleaned, roughened, free from loose particles, wet.
2. Remove column concrete cover to expose reinforcement. Casting operation must meet conditions of point 1.
3. Section of existing column to be integrated with new column.
4. Reinforcement of existing column to be integrated with new column.

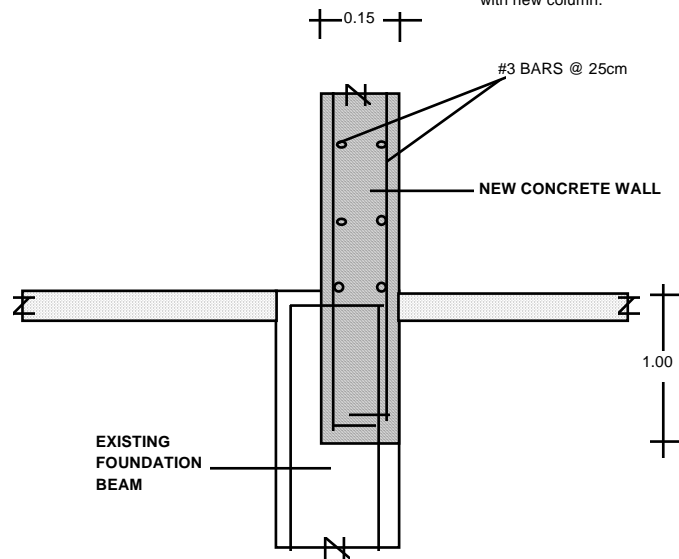

SECTION A-A

Figure 5.E15 New R/C columns and walls: anchorage to foundation.

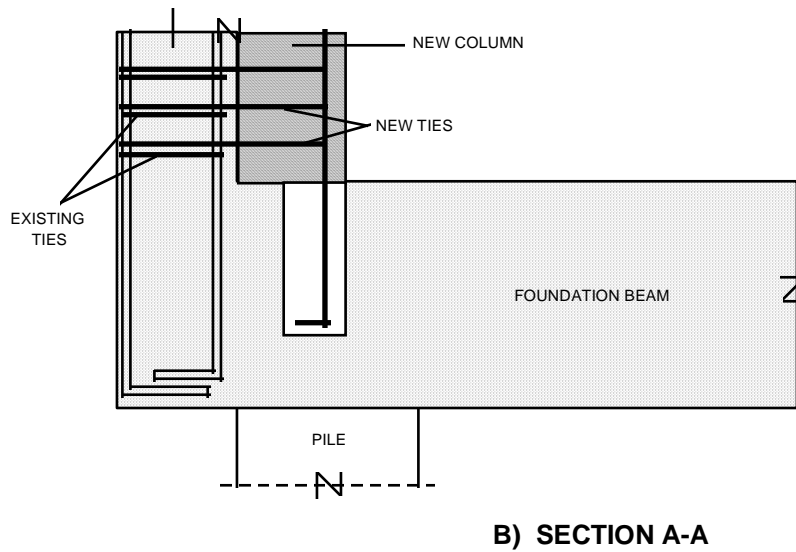
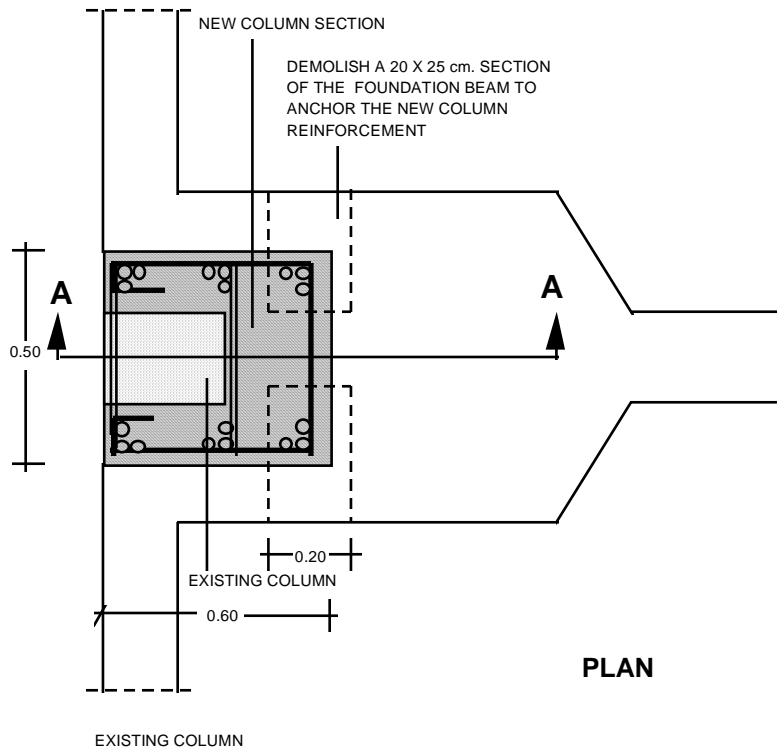
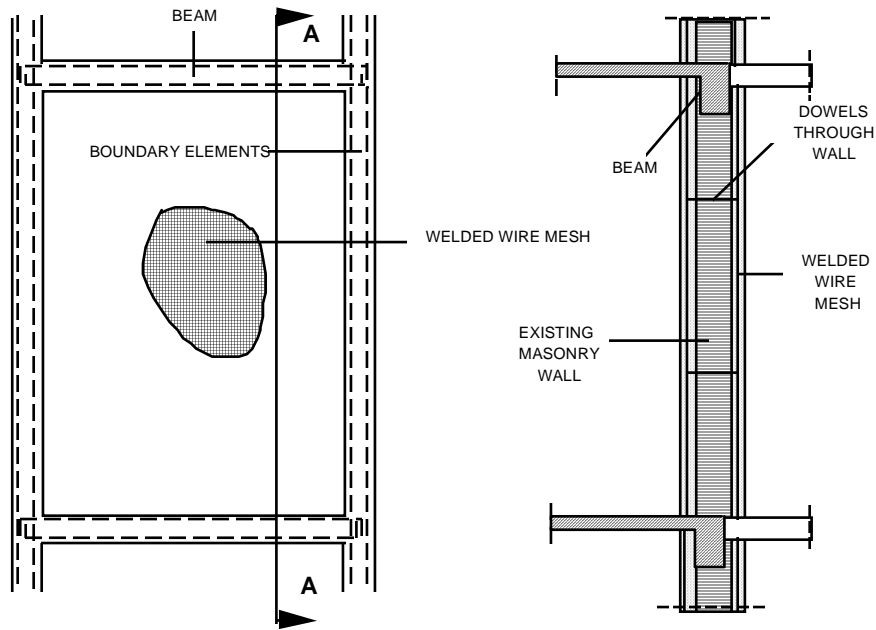

Figure 5.E16 Reinforcement and anchorage of new columns.



NOTE:
 If boundary elements confining the masonry wall are damaged, they should be demolished and replaced by new elements with the same size and reinforcement.

SECTION A-A

Figure 5.E17 Repair of damaged masonry walls.

In the design approach, the model of the retrofitted structure was analyzed assuming that only the new frames would resist the lateral forces in the short direction (E-W). For the columns with increased sections, strengths were computed assuming monolithic behavior of the new and existing elements. In this direction the ductility reduction factor was taken as $Q= 4.0$ as indicated in the 1985 Emergency Norms, which were in effect when the design was done.

A ductility factor of 4.0 was allowed when at least 50% of the lateral loads are carried by unbraced reinforced concrete frames with ductile detailing.

In the N-S direction a ductility factor $Q=3.0$ was used. However, the new 1987 Building Code assigned a factor $Q=2.0$ for structures in which the lateral strength is provided by masonry walls, as in the upper stories in the N-S direction of the building.



Figure 5.E18 Repaired building.

5.6 BUILDING F

Building Description

The building was constructed in 1966 and is used for office and commercial purposes. The structure is divided in two independent units; unit A has a regular plan with a basement and eight floors, unit B also has a regular plan with a basement and six floors, as shown in Figures 5.F1 and 5.F2. The building has an area of approximately 1600 m² per floor.

The original structure consists of reinforced concrete frames with haunched beams. The floor system is a two way slab with beams. The foundation consists of reinforced concrete slabs and beams, with retaining walls along the perimeter that are not connected to the foundation beams.

In the 1979 earthquake the structure had some damage, mainly light cracking of structural elements. It was strengthened with the addition of three reinforced concrete walls, 15 cm thick, anchored to the existing reinforcement and their boundary columns enlarged. Also, two masonry walls were strengthened with wire mesh and a mortar layer on both faces, as noted in Figure 5.F1.

Figures 5.F3 and 5.F4 show construction details of the connection between the concrete walls, added after the 1979 earthquake, and the existing structure.

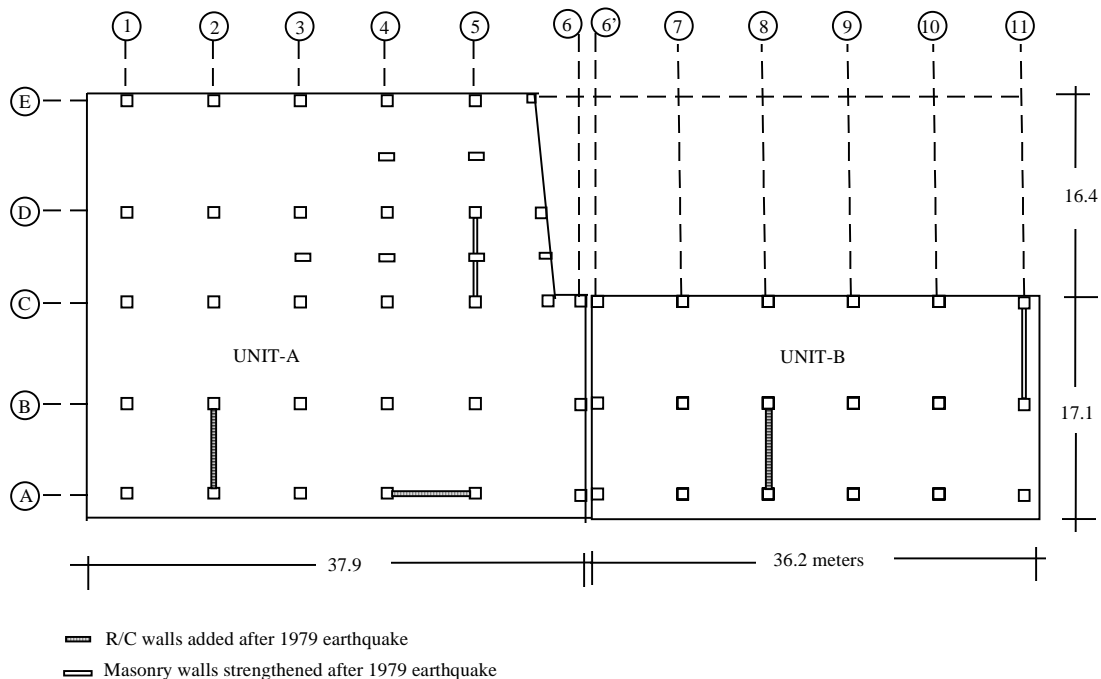

Figure 5.F1 Typical floor plan.

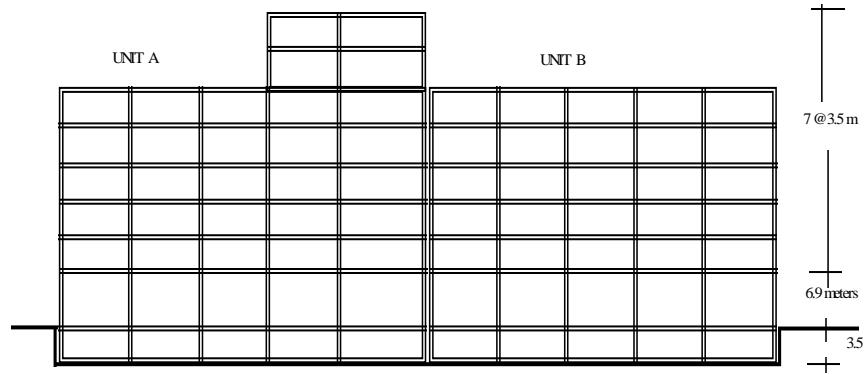

Figure 5.F2 Building elevation along line C.

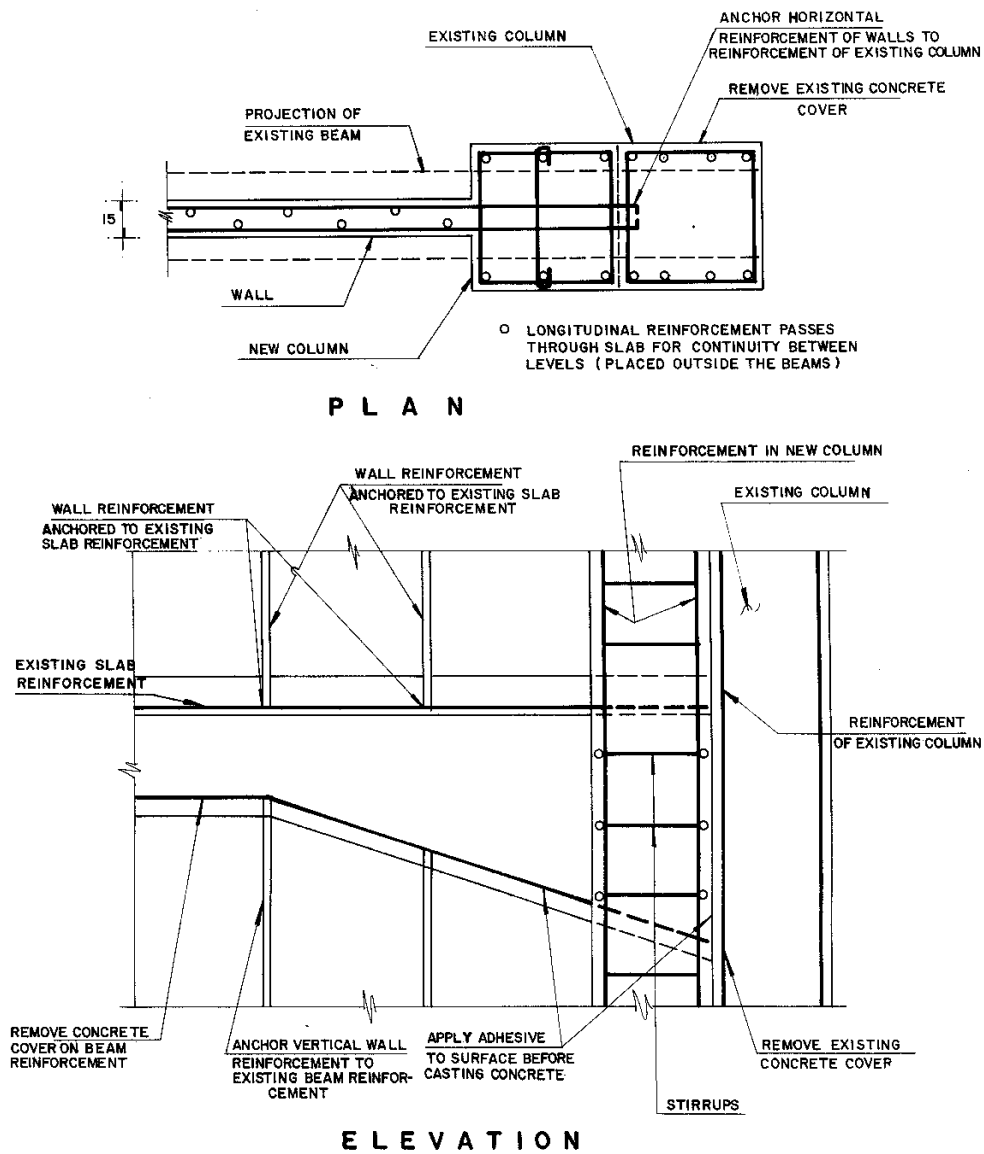
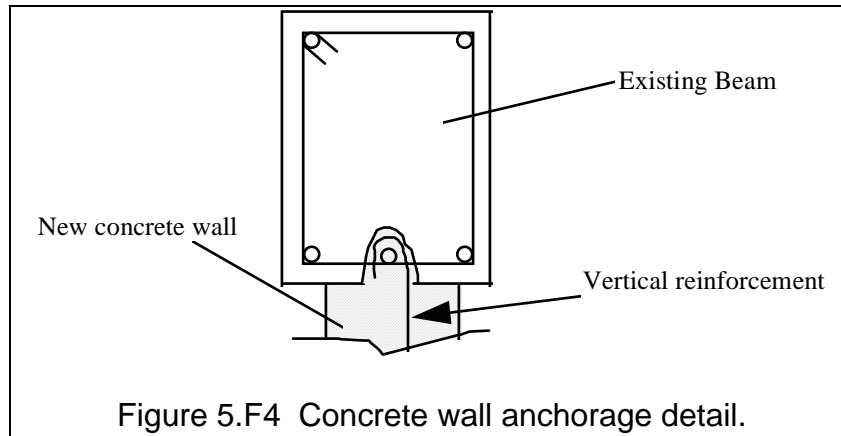

Figure 5.F3 Connection detail of concrete walls added after 1979 earthquake.



Description of Damage After the 1985 Earthquake

Damage in the 1985 earthquake occurred mainly at the first level with the columns suffering the most damage. The walls added after 1979 to strengthen the structure spalled and left the steel reinforcement exposed. The intensity of damage decreased in the upper floors. There was no damage to the foundation.

In the three lower stories, the boundary columns of the walls strengthened after the 1979 earthquake had severe damage (Fig. 5.F5). The column C-5 was the most damaged and included fractured bars as shown in Figure 5.F6. Approximately 30% of the rest of the columns on these levels had crack widths of one millimeter or more. On the upper levels the number of damaged columns and the width of the cracks decreased.

The concrete walls lost material at wall-column and wall-beam connections, as shown in Figures 5.F7 and 5.F8. It was evident that the anchorage between added walls and existing elements was deficient (Fig. 5.F9). Also, poor quality materials and construction were observed in the concrete walls added after the 1979 earthquake.

On the second story, the beams on line 1, between E and D, and line 4, between C and D, lost concrete cover. The rest of the beams and slabs did not suffer any damage. Before the 1985 earthquake some of the beams had diagonal cracks, but the crack width, length and number did not increase after the earthquake.

Masonry partition walls had severe damage in the first five stories, and some collapsed. There was moderate damage to walls in upper stories.

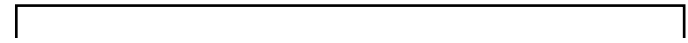

Figure 5.F5 Typical damage in boundary columns.

Figure 5.F6 Damage in column C-5.

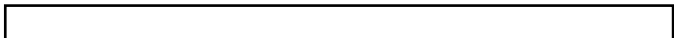

Figure 5.F7 Damage in concrete walls.

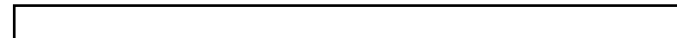

Figure 5.F8 Damage in concrete walls.



Figure 5.F9 Wall-beam anchorages.

Temporary Measures

During the repair and strengthening procedure, shoring was provided to support vertical loads. In those columns where it was necessary to replace the damaged concrete, the shoring consisted of tubular steel elements with steel base plates at ends. These elements were placed around the columns and restrained with wire ties to avoid buckling. The shoring was intended to be continuous along the height of the structure to transmit the loads directly to the foundation (Fig. 5.F10 and 5.F11). No bracing was provided for lateral forces.

The existing structure was analyzed according to the provisions of the 1985 Emergency Norms. The ductility reduction factor was taken as $Q=2$.

The observed damage and the results of the analysis were consistent.

Based on the results of the analysis of the structure and its performance during previous earthquakes, a strengthening approach was developed with the objective of

increasing the overall stiffness of the building and the strength of the columns. The strengthened structure was analyzed assuming monolithic behavior between new and existing elements.

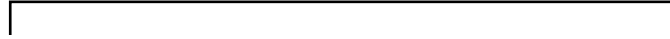

Fig. 5.F10 Shoring for vertical loads.



Fig. 5.F11 Shoring for vertical loads.

Strengthening Procedure

The strengthening approach consisted of adding reinforced concrete walls, 20 cm thick, and upgrading boundary columns with concrete jackets. Seriously damaged masonry and concrete walls were demolished and replaced by new walls. In concrete walls with moderate damage, cracks were injected with epoxy resins and their thickness was increased to 20 cm. The layout of strengthened and new concrete walls is shown in Figure 5.F12. Connections between walls and existing elements consisted of epoxy grouted dowels. Details of this procedure can be seen in Figures 5.F13 to 5.F14.

Before jacketing boundary columns with buckled bars, the damaged concrete and reinforcement were replaced. The same amount of reinforcement was provided, welded to the existing bars, and ties were added. In columns with less damage, the cracks were injected with epoxy resin.

The rest of the columns were jacketed with two layers of wire mesh and shotcrete (Fig. 5.F15 and 5.F16). Cracks were injected with epoxy resin.

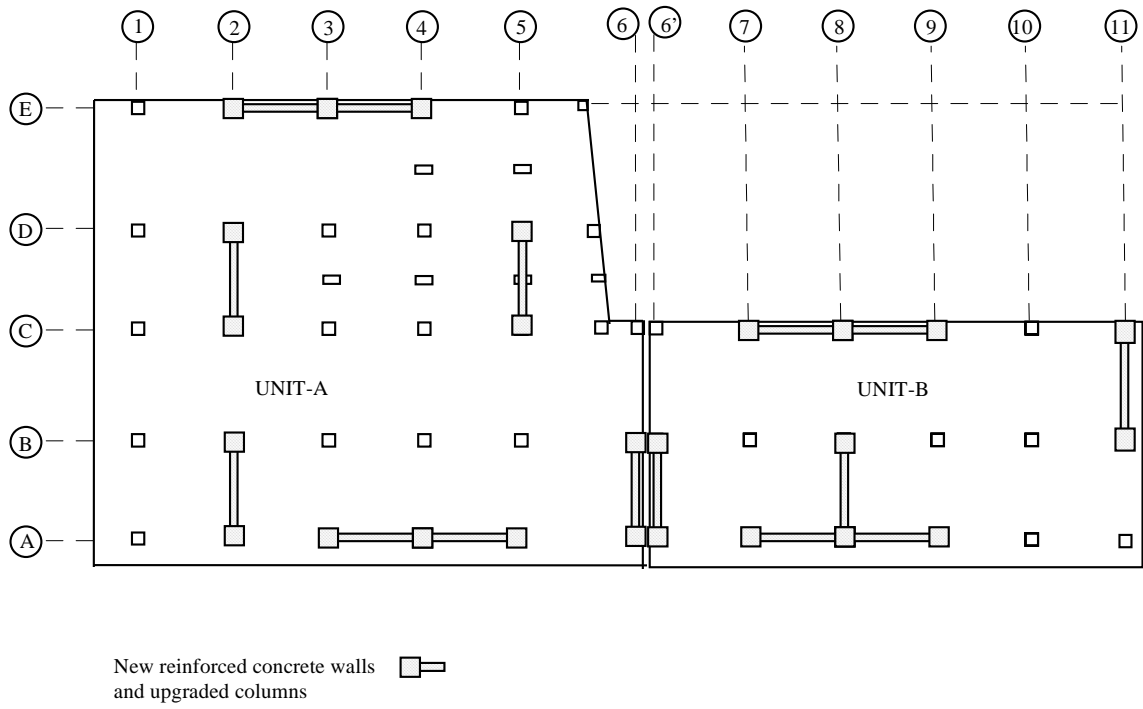

Figure 5.F12 Strengthening scheme.

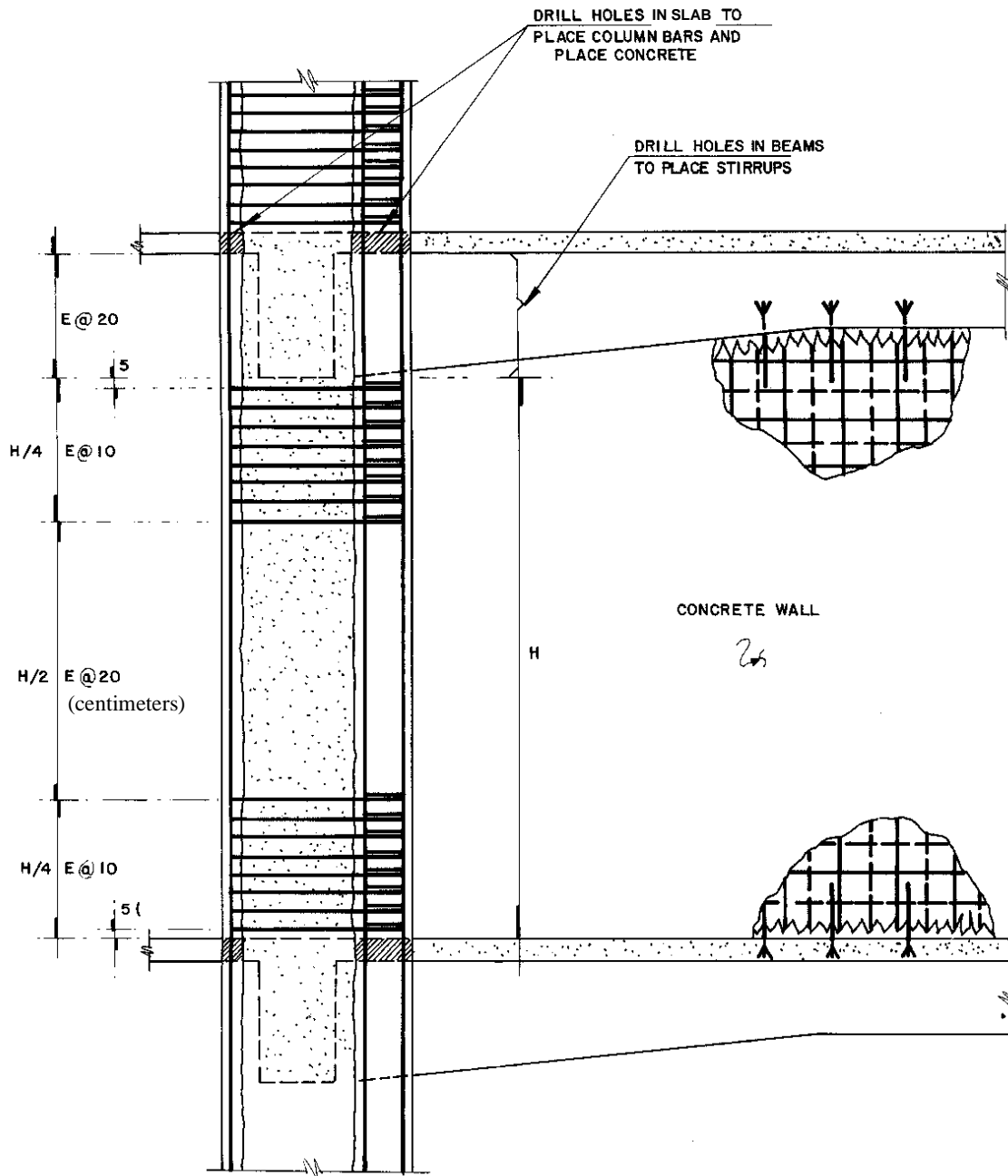

Figure 5.F13 Jacketing of existing columns and new concrete wall.

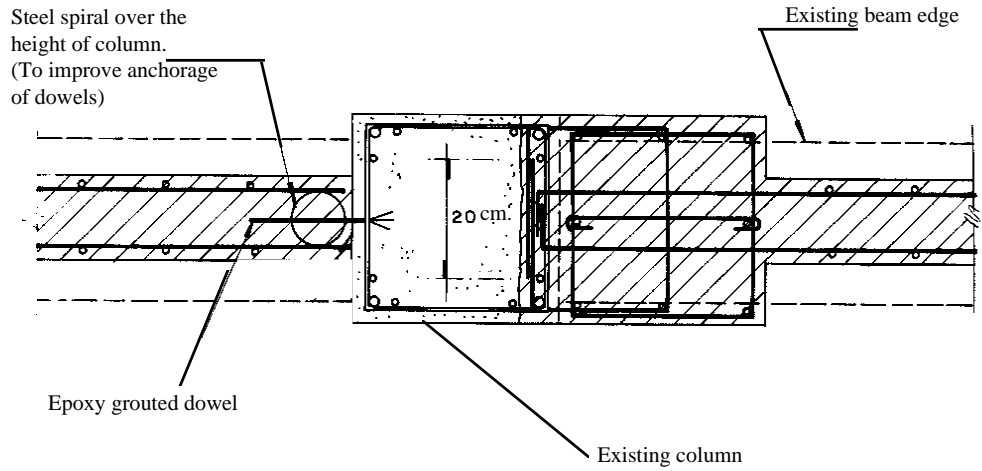

Figure 5.F14 Connection detail of new concrete wall in column C-5.

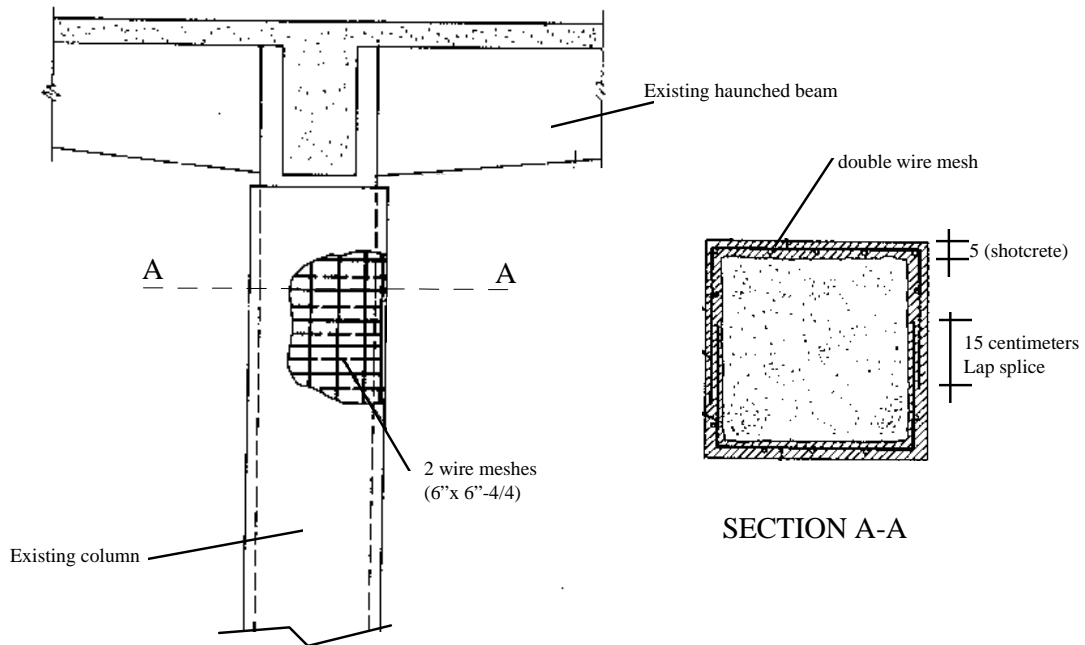

Figure 5.F15 Column jacking with shotcrete and wire mesh.



Figure 5.F16 Column jacketed with wire mesh and shotcrete.

To anchor the new reinforcement in the column jackets it was necessary to increase the width of the foundation beams. Retaining walls were connected to the upgraded foundation beams at the perimeter of the structure. It was considered unnecessary to add piles to the foundation.

5.6.1 BUILDING F

5.6.2 BUILDING DESCRIPTION

The building was constructed in 1966 and is used for office and commercial purposes. The structure is divided in two independent units; unit A has a regular plan with a basement and eight floors, unit B also has a regular plan with a basement and six floors, as shown in Figures 5.F1 and 5.F2. The building has an area of approximately 1600 m² per floor.

The original structure consists of reinforced concrete frames with haunched beams. The floor system is a two way slab with beams. The foundation consists of reinforced concrete slabs and beams, with retaining walls along the perimeter that are not connected to the foundation beams.

In the 1979 earthquake the structure had some damage, mainly light cracking of structural elements. It was strengthened with the addition of three reinforced concrete walls, 15 cm thick, anchored to the existing reinforcement and their boundary columns enlarged. Also, two masonry walls were strengthened with wire mesh and a mortar layer on both faces, as noted in Figure 5.F1.

Figures 5.F3 and 5.F4 show construction details of the connection between the concrete walls, added after the 1979 earthquake, and the existing structure.

5.6.3 DESCRIPTION OF DAMAGE AFTER THE 1985 EARTHQUAKE

Damage in the 1985 earthquake occurred mainly at the first level with the columns suffering the most damage. The walls added after 1979 to strengthen the structure spalled and left the steel reinforcement exposed. The intensity of damage decreased in the upper floors. There was no damage to the foundation.

In the three lower stories, the boundary columns of the walls strengthened after the 1979 earthquake had severe damage (Fig. 5.F5). The column C-5 was the most damaged and included fractured bars as shown in Figure 5.F6. Approximately 30% of the rest of the columns on these levels had crack widths of one millimeter or more. On the upper levels the number of damaged columns and the width of the cracks decreased.

The concrete walls lost material at wall-column and wall-beam connections, as shown in Figures 5.F7 and 5.F8. It was evident that the anchorage between added walls and existing elements was deficient (Fig. 5.F9). Also, poor quality materials and construction were observed in the concrete walls added after the 1979 earthquake.

On the second story, the beams on line 1, between E and D, and line 4, between C and D, lost concrete cover. The rest of the beams and slabs did not suffer any damage. Before the 1985 earthquake some of the beams had diagonal cracks, but the crack width, length and number did not increase after the earthquake.

Masonry partition walls had severe damage in the first five stories, and some collapsed. There was moderate damage to walls in upper stories.

5.6.4 TEMPORARY MEASURES

During the repair and strengthening procedure, shoring was provided to support vertical loads. In those columns where it was necessary to replace the damaged concrete, the shoring consisted of tubular steel elements with steel base plates at ends. These elements were placed around the columns and restrained with wire ties to avoid buckling. The shoring was intended to be continuous along the height of the

structure to transmit the loads directly to the foundation (Fig. 5.F10 and 5.F11). No bracing was provided for lateral forces.

The existing structure was analyzed according to the provisions of the 1985 Emergency Norms. The ductility reduction factor was taken as $Q=2$.

The observed damage and the results of the analysis were consistent.

Based on the results of the analysis of the structure and its performance during previous earthquakes, a strengthening approach was developed with the objective of increasing the overall stiffness of the building and the strength of the columns. The strengthened structure was analyzed assuming monolithic behavior between new and existing elements.

5.7. STRENGTHENING PROCEDURE

The strengthening approach consisted of adding reinforced concrete walls, 20 cm thick, and upgrading boundary columns with concrete jackets. Seriously damaged masonry and concrete walls were demolished and replaced by new walls. In concrete walls with moderate damage, cracks were injected with epoxy resins and their thickness was increased to 20 cm. The layout of strengthened and new concrete walls is shown in Figure 5.F12. Connections between walls and existing elements consisted of epoxy grouted dowels. Details of this procedure can be seen in Figures 5.F13 to 5.F14.

Before jacketing boundary columns with buckled bars, the damaged concrete and reinforcement were replaced. The same amount of reinforcement was provided, welded to the existing bars, and ties were added. In columns with less damage, the cracks were injected with epoxy resin.

The rest of the columns were jacketed with two layers of wire mesh and shotcrete (Fig. 5.F15 and 5.F16). Cracks were injected with epoxy resin.

To anchor the new reinforcement in the column jackets it was necessary to increase the width of the foundation beams. Retaining walls were connected to the upgraded foundation beams at the perimeter of the structure. It was considered unnecessary to add piles to the foundation.

Figure 5.F13 Jacketing of existing columns and new concrete wall.

5.7 BUILDING G

Building Description

The eleven story building was constructed in 1980 in the lake bed zone of Mexico City, about 300 meters from the site of the SCT accelerometer which registered the maximum acceleration recorded in the 1985 earthquake. It has an area of approximately 246 m² per floor and is used for office purposes (Fig. 5.G1 and 5.G2). The structure consists of reinforced concrete columns and waffle slabs. There are also reinforced concrete shear walls on the north and south boundary lines of the building, and in the elevator core. The foundation system consists of a box, 1.5 m deep, supported by friction piles. Partition walls are unreinforced brick masonry confined by reinforced concrete boundary elements.

Description of Damage After the 1985 Earthquake

Columns had cracks of less than 1 mm from the basement to the third story. From the fourth floor and up, the cracks were wider than 1 mm and appeared mainly in the columns along line 2 (Fig. 5.G3 and 5.G4).

Shear walls around the elevator shaft had diagonal cracks and spalling that exposed reinforcement from the first to the ninth story (Fig. 5.G5). There was moderate cracking of masonry partition walls on the lower floors, and severe damage of the masonry walls around the stairs. Damage was concentrated in the short direction (N-S) because the boundary concrete walls in the long direction (E-W) performed very well.

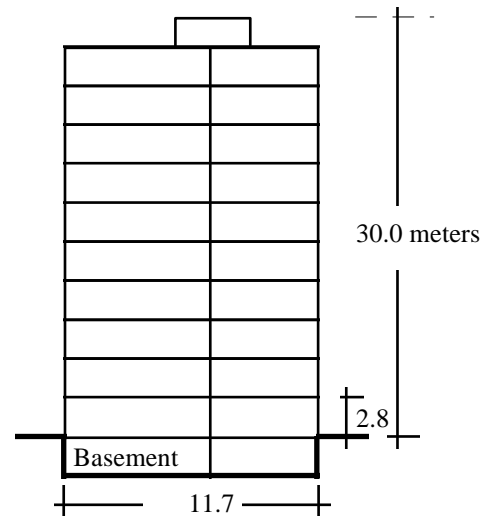

Figure 5.G1 Building elevation.

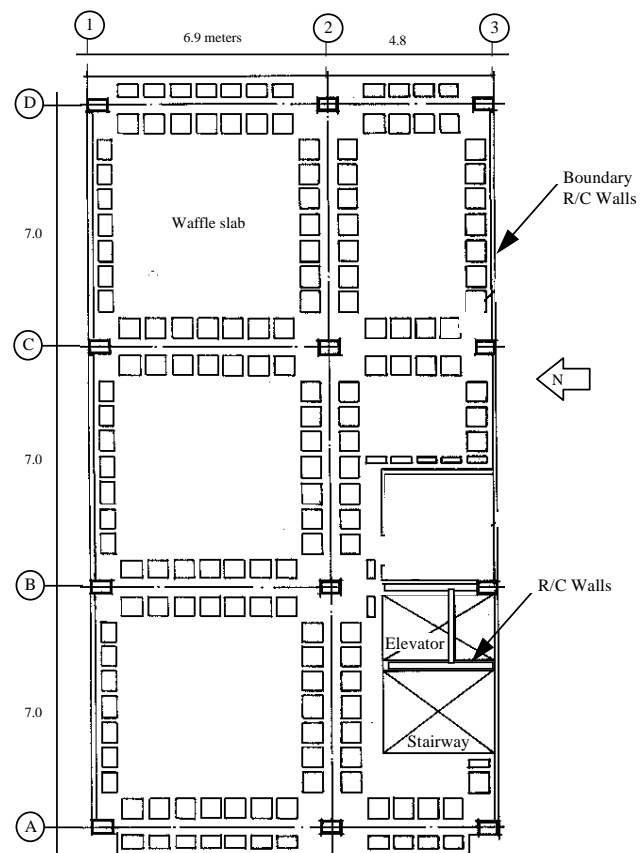

Figure 5.G2 Typical plan.

Figure 5.G3 Damage at slab-column joint.

Figure 5.G4 Cracks in column at sewer pipe location.

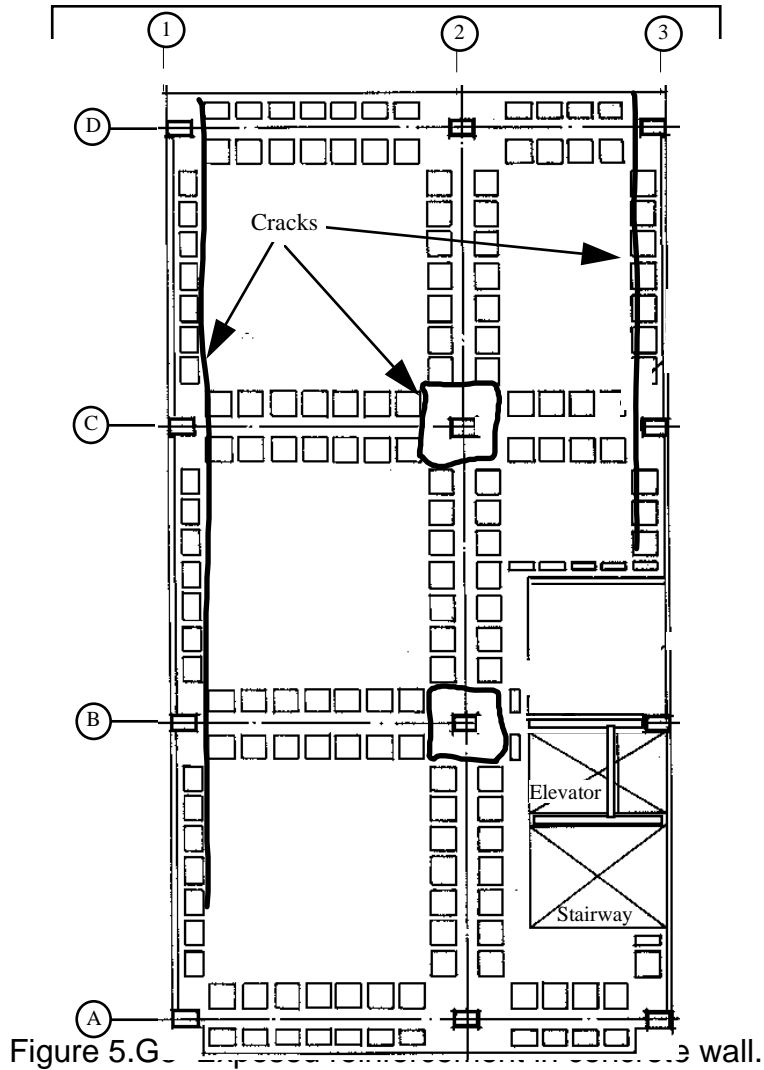

Fig. 5.G6 Crack pattern in waffle slab.

Punching shear failure around the rigid zone of the waffle slab, at columns C2 and B2, was evident from the basement to the sixth story. There were also cracks parallel to lines 1 and 3, with an offset from these lines of 0.5 m, that appeared to be a yield line indicative of low slab flexural capacity. These cracks appeared from levels 2 through 7 (Fig. 5.G6).

Strengthening Procedure

The strengthening approach consisted mainly of adding two reinforced concrete infill walls along lines B and C, between lines 2 and 3. These walls were 20 cm thick and were connected to the slab using anchor bolts. Their arrangement is shown in Figures 5.G7 and 5.G8. Damaged walls around the stairs were rebuilt.

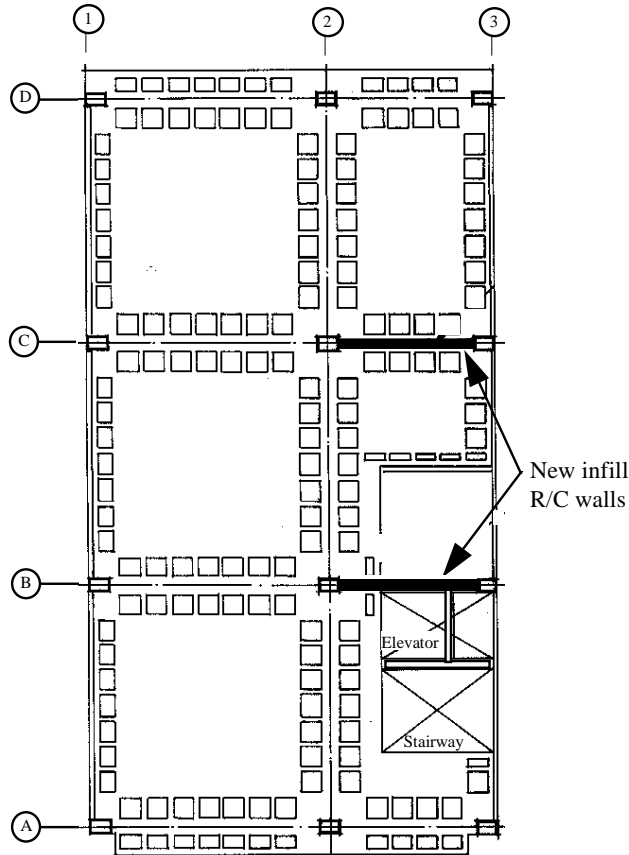

Figure 5.G7 Layout of new concrete walls.

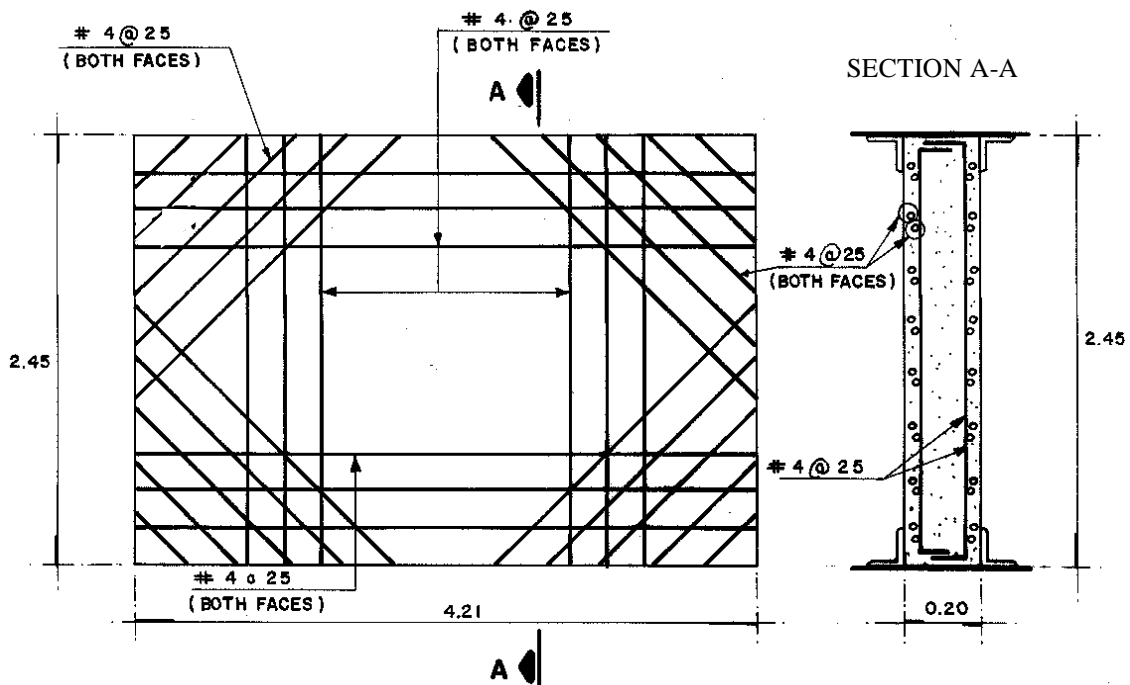

Figure 5.G8 Infill concrete wall reinforcement.

The columns at the ends of the new walls were strengthened with steel jackets made up of steel angles placed on the corners of the column and straps welded to the angles (Fig. 5.G9 and 5.G10).

During construction, a review of the original strengthening project, indicated that the capacity of the column was inadequate and the steel jacketing was supplemented by a reinforced concrete jacket with continuous longitudinal reinforcement through the slab (Fig. 5.G11).

The waffle slab was repaired with epoxy injection. The cracks were injected with resins by placing tubes along the cracks and injecting the resins, as shown in Figures 5.G12 and 5.G13.



Figure 5.G9 Infill wall reinforcement and steel jacketing.

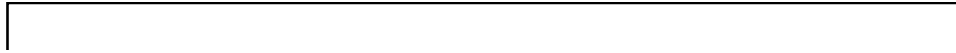

Figure 5.G10 Infill wall before concrete jacking of columns.

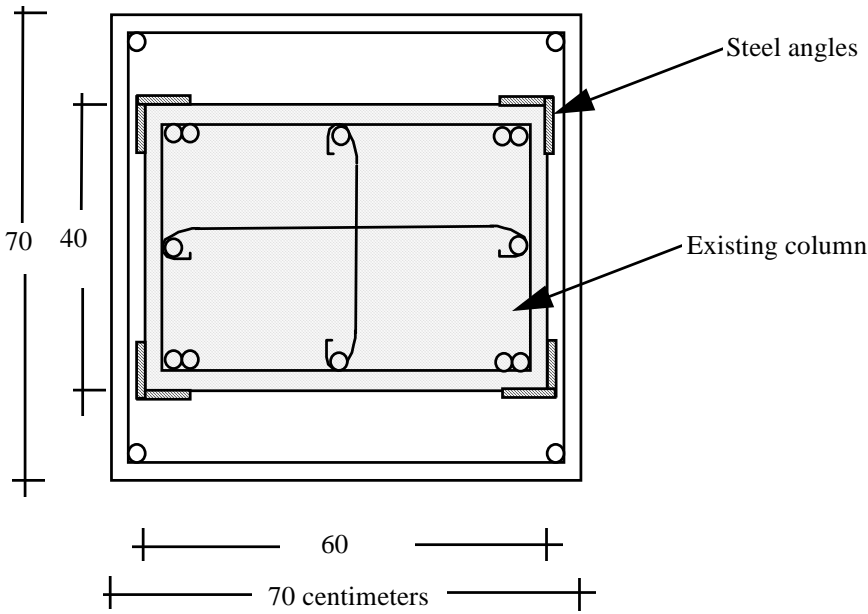

Figure 5.G11 Jacketing of B-2 column in first story,

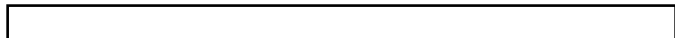

Figure 5.G12 Epoxy injection in waffle slab cracks.

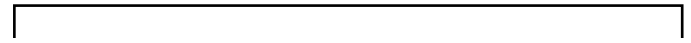

Figure 5.G13 Injections in waffle slab cracks.

5.8 BUILDING H

Building Description

The building was constructed in the lake zone of Mexico City in 1975. It is an office building with an area of approximately 291 m² per floor and includes a basement and seven floor levels (Fig. 5.H1 and 5.H2). The original structure was a waffle slab supported on reinforced concrete columns. The foundation system consists of a box foundation, 2.25 m deep forming the basement, supported by friction piles. There were masonry infill walls along boundary lines 1 and 4, and around the elevator shaft.

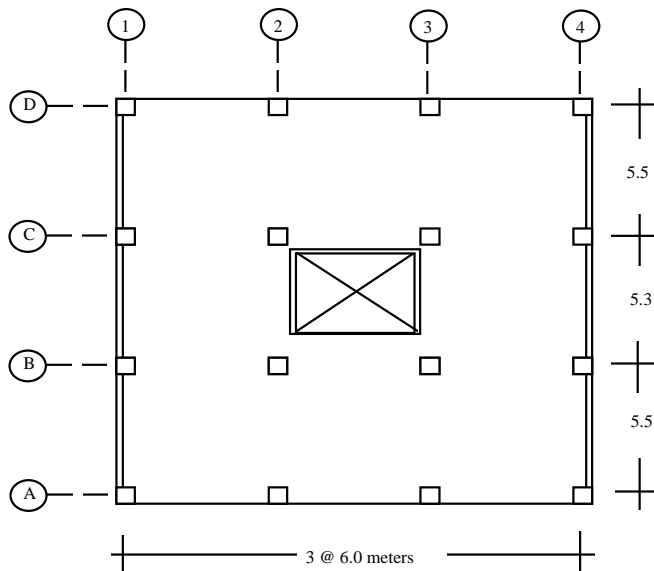

Figure 5.H1 Typical plan

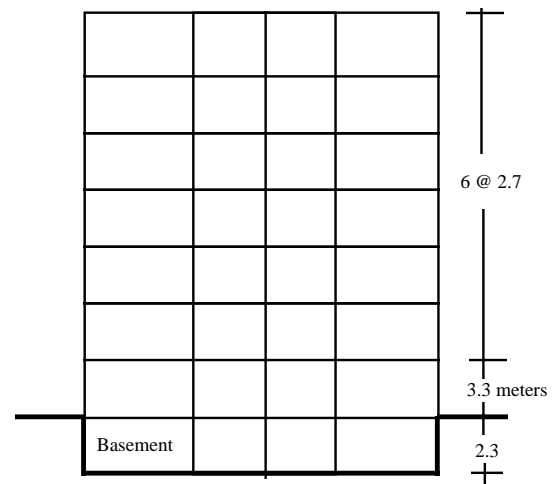

Figure 5.H2 Building elevation.

Description of Damage After the 1985 Earthquake

The most damaged structural elements were columns in the first three stories. The main cause of damage was the presence of masonry curtain walls on the back facade, line D, which were not isolated from the structural system. From the second to seventh story, curtain walls reduced the effective length of the columns to one half of the height between floors. These resulted in short column failure of column D-3, in the second story, and induced torsional effects (Fig. 5.H3).

Column A-1 had damage in third story due to pounding with the adjacent building. The roof of that building is at the mid story height of the column (Fig 5.H4 and 5.H5).

The columns around the elevator shaft and on line A had cracks, about 1 mm width, in stories 2 and 3. Also, masonry walls around the elevator shaft had severe

damage in those stories. The waffle slab was not damaged, but cracks due to punching shear were observed around column B-3 in the second floor.

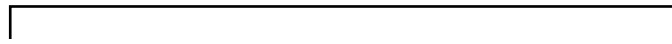

Figure 5.H3 Damage in column D-3.

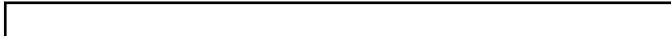

Figure 5.H4 Pounding with adjacent building.

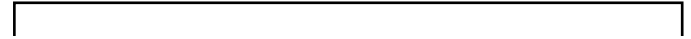

Figure 5.H5 Damage in column A-1 due to pounding with adjacent building.

Temporary Measures

During retrofitting, shoring was provided from the basement to the third story to stabilize the existing structure, especially around the most damaged columns. The shoring consisted of wood elements placed as shown in Figure 5.H6. Timber braces were used, but were probably too light to provide lateral load resistance.



Figure 5.H6 Shoring in the lower stories.

Strengthening Procedure

The strengthening approach consisted basically of addition of concrete walls and concrete jacketing of columns in the lower stories. Two reinforced concrete walls, 25 cm width, were placed in boundary lines 1 and 4. Three walls, 20 cm width, were placed around the elevator core as shown in Figure 5.H7. All concrete walls extended from basement to the roof level and the boundary columns were strengthened with concrete jacketing. Ribs of the waffle slab along the column lines, from the basement to level 5, were upgraded and connected to the walls using the detail presented in Figure 5.H8.

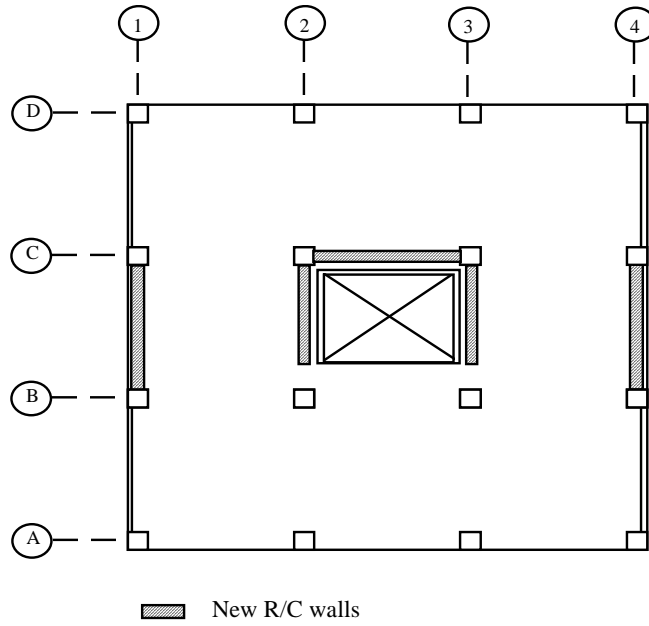

Figure 5.H7 Layout of new reinforced concrete wall.

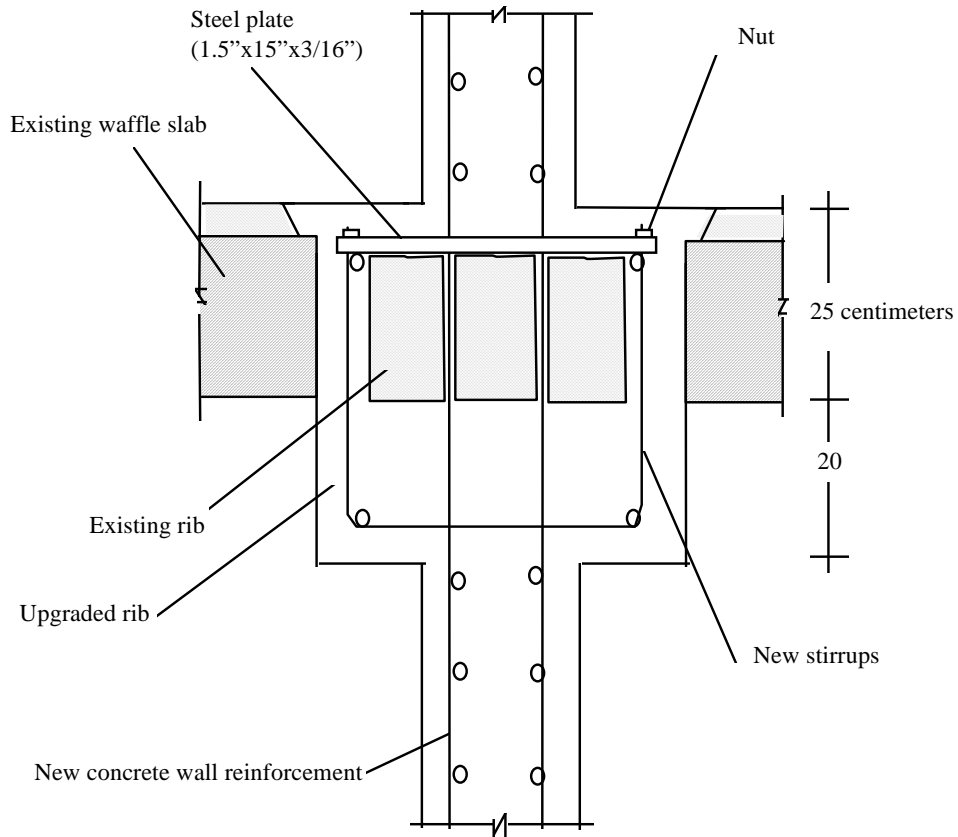

Figure 5.H8 Strengthening of ribs on column lines and connection with walls

The vertical reinforcement of the walls was extended into the existing foundation beams. For this purpose, the beams were partially demolished and recast using concrete with epoxy additive. The sectional area of the foundation beams was not increased or strengthened in any way (Fig. 5.H9).

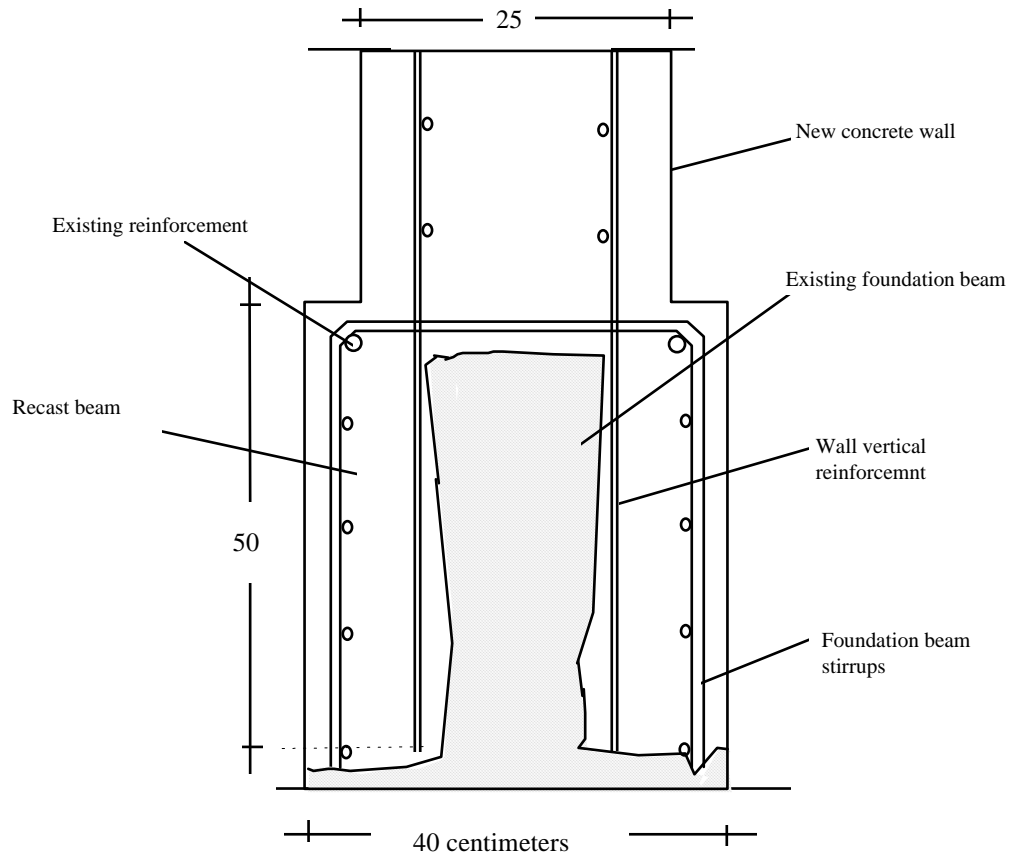

Figure 5.H9 Anchorage of concrete walls to foundation beams.

Jacketing with additional reinforcement was provided for all columns from the basement to the fifth level. Figure 5.H10 shows the jacketing columns on boundary lines 1 and 4. Severely damaged, columns A-1 and D-3 on the second level, were partially demolished and rebuilt.

It is important to note that the interior columns, which originally had a constant cross section had an abrupt change of section from level 5 (70x70 cm) to level 6 (45x45 cm) after jacketing.

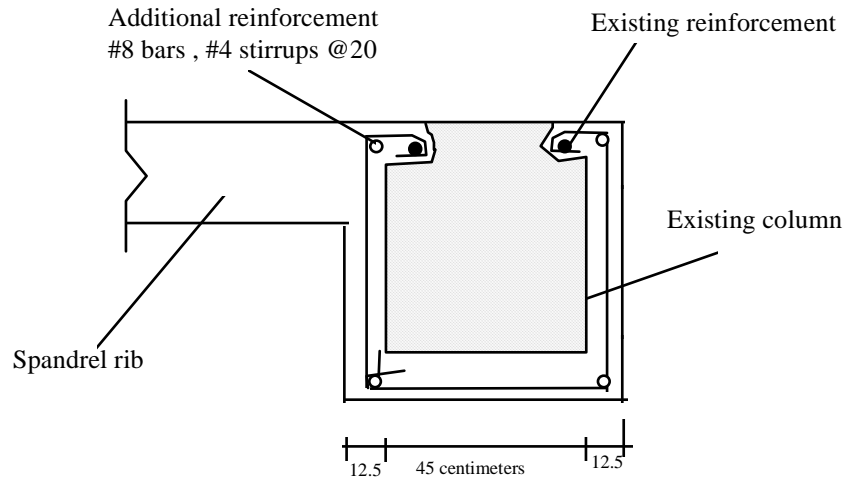

Figure 5.H10 Jacketing detail of column on boundary line.

Furthermore, cracked regions in ribs of the waffle slab around the columns were demolished and upgraded.

All the non-structural masonry walls were isolated from the rest of the structure to avoid short-columns problems.

It was necessary to add ten point-bearing piles, 25.5 m long, and foundation beams below the concrete walls. The concrete piles had an octagonal section and were placed in short lengths with a center hole core, in which reinforcement was driven. The hole was then grouted. Photographs of the installation of piles are shown in Figure 5.H11 and 5.H12.



Figure 5.H11 Installation of pile sections.



Figure 5.H12 Installation of pile sections.

5.9 BUILDING I

Building Description

The building is located in the lake bed zone in Mexico City. It has a basement and four stories above with an area of approximately 326 m² per floor (Fig. 5.11 and 5.12). The building is used to house heavy telephone switching equipment in the upper stories and an electric substation in the basement. There is an adjacent 2 story building along line A, between lines 5 and 8, whose roof coincides with the first level of this building.

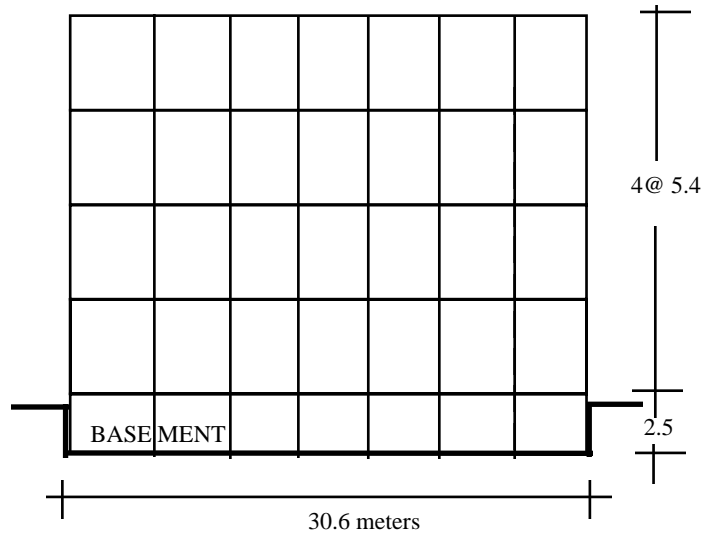

Figure 5.11 Building elevation.

The structure consists of reinforced concrete frames and two way slabs. Partitions and service core bearing walls are unreinforced hollow concrete block masonry walls. The foundation system is a concrete box, forming the basement, supported on control piles.

Description of Damage After the 1985 Earthquake

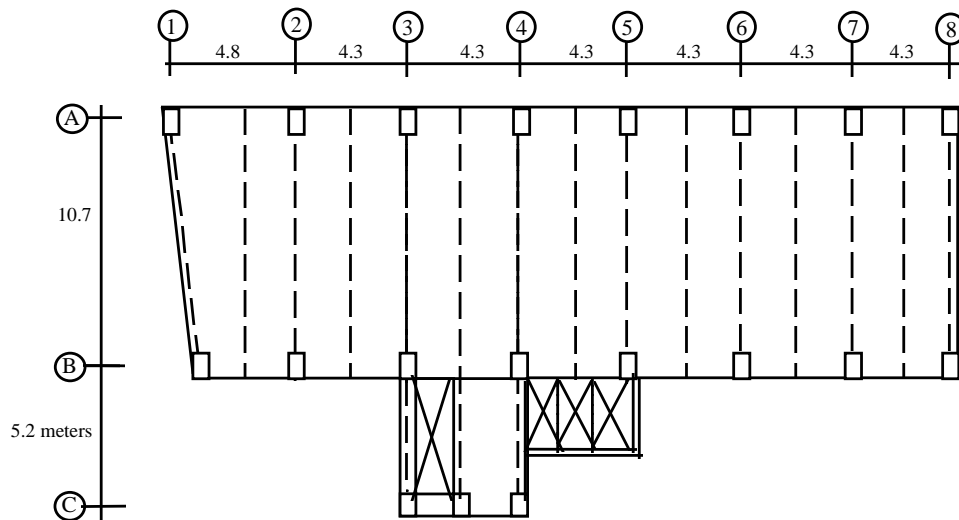

Figure 5.12 Typical plan.

The asymmetric building plan, due to the position of the service core, created torsional effects in the structure. Furthermore, there was pounding with the adjacent building because the separation was too small. As a result, the corner columns on line 8 were severely damaged, and spalling of concrete occurred at all levels. Also, the beam-column joints and beams on this column line had extensive diagonal cracking.

Nearly all the remaining columns experienced some cracking at all stories. Columns around the service core and on line A had cracks of more than 1 mm width. Also, all the beams had diagonal cracks in the first three levels, the most damaged were those on lines 1 and 8.

The slabs had been cracked before the 1985 earthquake. After the earthquake these cracks became more noticeable. None of the cracks was more than 1 mm wide.

The facade and service core walls were completely fractured in stories 2 and 3. The partition walls had moderate cracking. Most of these walls were hit by equipment (switching units) that were poorly fastened. In the original design, all walls were considered to be non-structural, but were, in fact, infill walls connected to the structural system.

In most control pile caps the threaded anchor rods of the control device buckled, as shown in Figures 5.13 and 5.14.

Temporary Measures

After the 1985 earthquake, shoring for vertical loads was provided in all stories and the telephone equipment units were protected with plastic covers and kept in operation, even during the retrofitting construction. The shoring consisted of braced wood elements with steel pipes carrying vertical loads, as shown in Figure 5.15.

For the strengthening project different alternatives were analyzed. The addition of concrete walls or steel bracing were considered the most feasible techniques. A decision was made to use concrete walls because the estimated time of construction was less and because the telephone equipment had to remain in operation. In the redesign, the intent was to eliminate torsional effects in the structure and to meet provisions of the 1985 Emergency Norms for structures of Group A, which includes communication buildings. An importance factor of 1.5 is applied for the seismic design.



Figure 5.13 Buckling of anchor rods in control pile caps.



Figure 5.14 Damaged anchor rods in control pile caps.

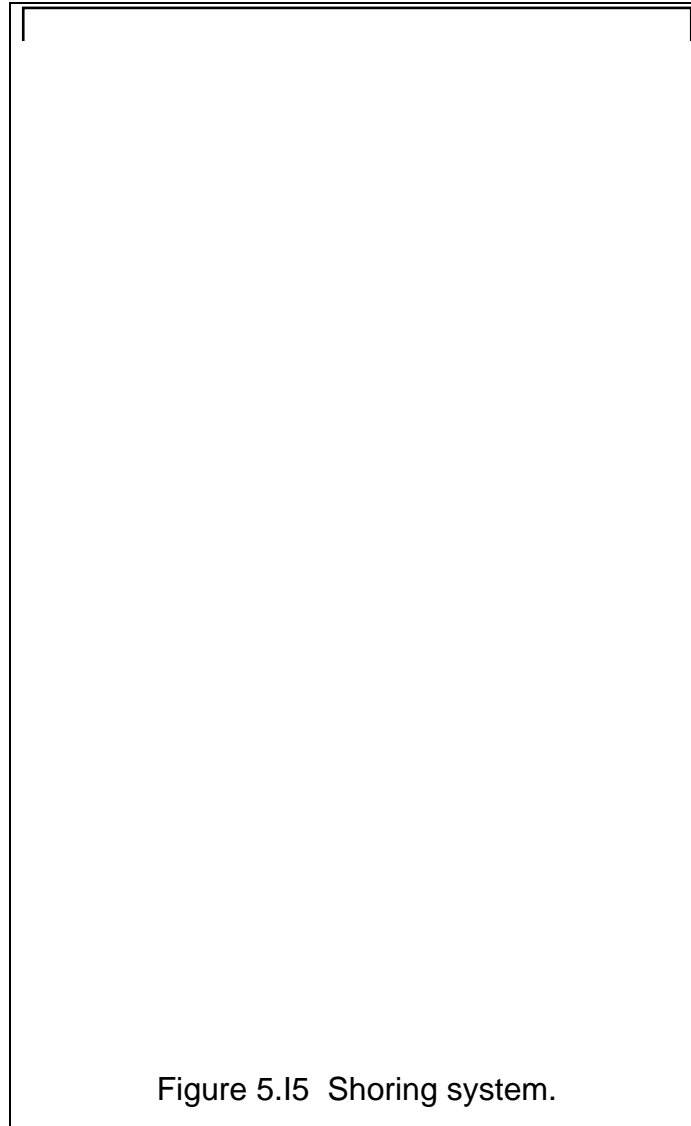

Strengthening Procedure

In the short direction, “C” shaped walls (25 cm thick) were placed at both ends of the building. Also, concrete walls (20 cm thick) were added to the service core and along line A. The walls were continuous from the foundation to the roof. The columns at the corners and the three columns on line C were demolished and recast along with the new walls. The arrangement of reinforced concrete walls is shown in Figure 5.16.

The columns in the boundary and outside the walls were jacketed with reinforced concrete. In Figure 5.17 a typical plan view of the column jacket is presented. The beams were jacketed only at the joint region over a length of about 1.10 meters from the existing columns. Figure 5.18 shows the alternatives used for beam jacketing. Alternative 2 was used in the beams below operating telephone equipment units, and alternative 1 for all others.

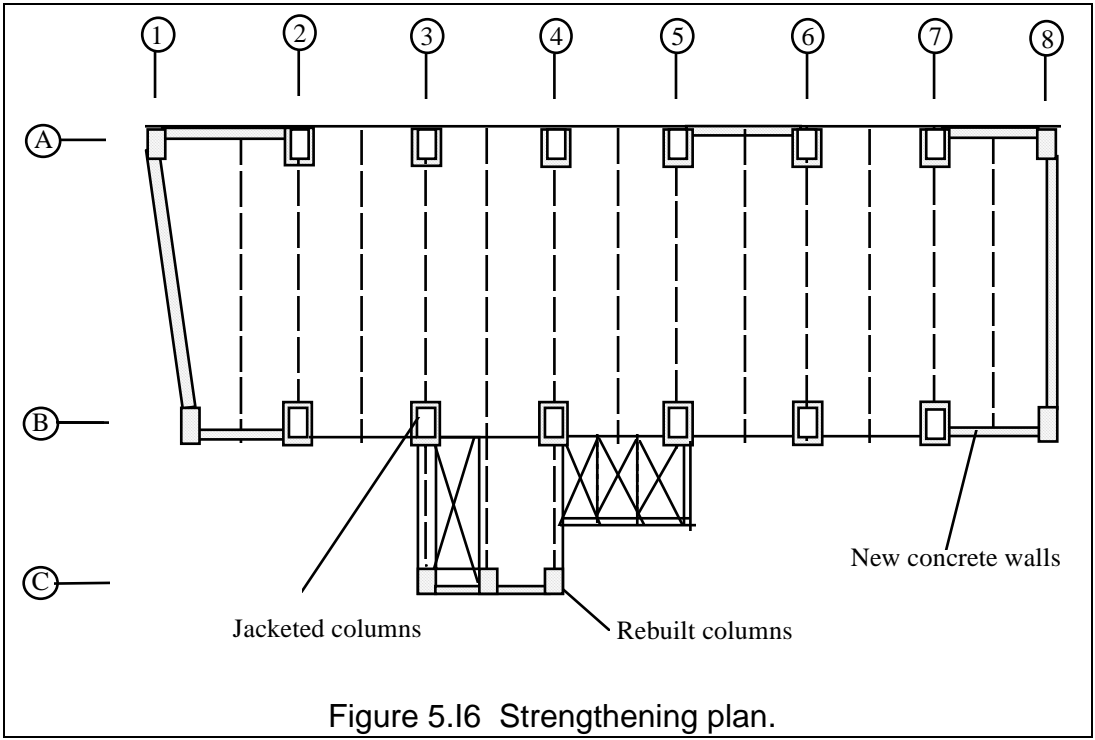

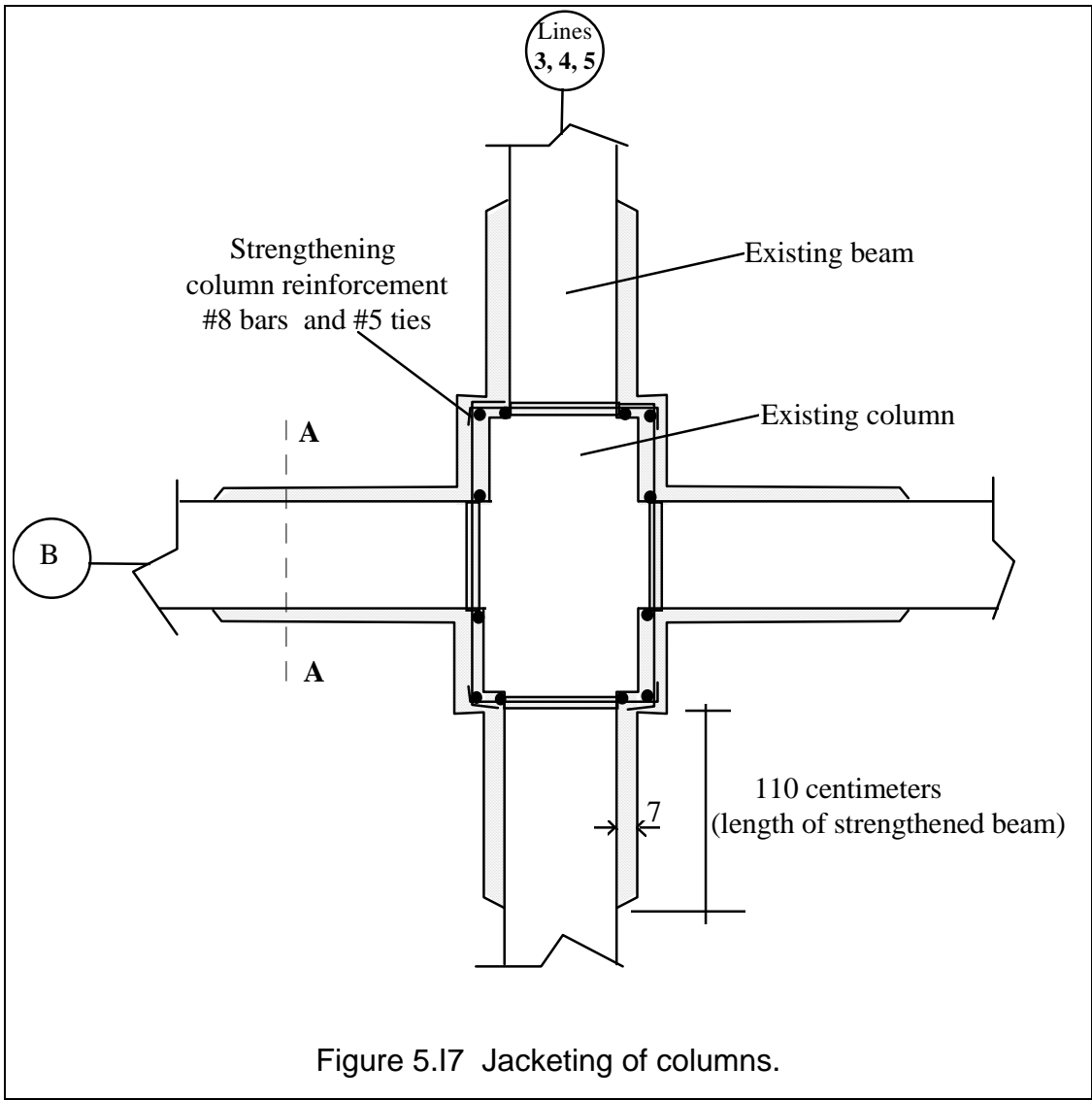

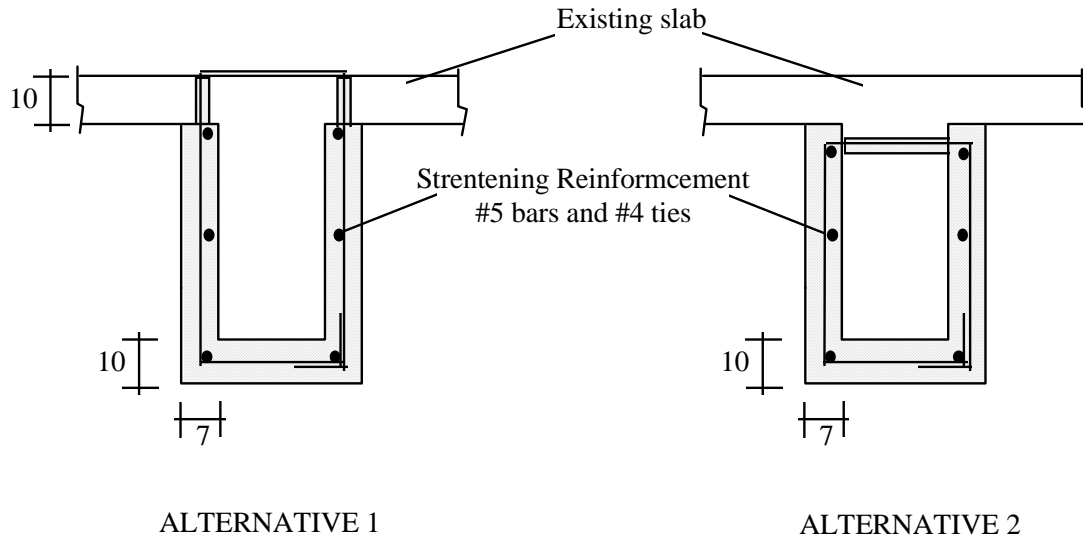

Figure 5.18 Detail of beam strengthening (Section A-A in Fig. 5.17).

The concrete strength used for retrofitting was $f'c=250 \text{ kg/cm}^2$ with additives to control volume changes. The existing structure was built with the same concrete strength. To increase bond between existing and new concrete, the surface of strengthened elements was chipped and wetted to saturation for at least two hours before casting. Cracks in existing elements with widths of 1.0 mm and greater were injected with epoxy resins prior to jacketing.

The foundation system, with 24 existing piles ($\varnothing=50 \text{ cm}$), was upgraded with 70 new control piles (30x30 cm, 27.0 m long) beneath the concrete walls. The damaged pile control devices were replaced, as shown in Figure 5.19. The foundation slab was also upgraded by adding a new slab on top of the existing slab along the perimeter of the building where the new piles were placed.

The building's configuration and the strengthening scheme allowed maintaining the building's operation. According to the telephone company, the equipment in this building which controls 28,000 telephone lines maintained operations at 98% of capacity during the construction work. The retrofitted building is shown in Figure 5.110.



Figure 5.19 New control devices on pile caps.

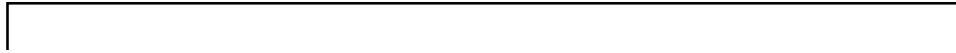

Figure 5.110 Retrofitted building.

5.10 BUILDING J

Building Description

The building is located in the lake bed zone of Mexico City, west of the downtown area. The structure was built in 1974 and is used as an office building. It is six stories high with a basement and a penthouse. The approximate floor area is 460 m². (Fig. 5.J1 and 5.J2).

The original structural system consists of reinforced concrete columns with a waffle slab floor. The foundation is a box foundation on friction piles. The infill walls on the boundary lines A and D and the partitions are of solid clay brick masonry.

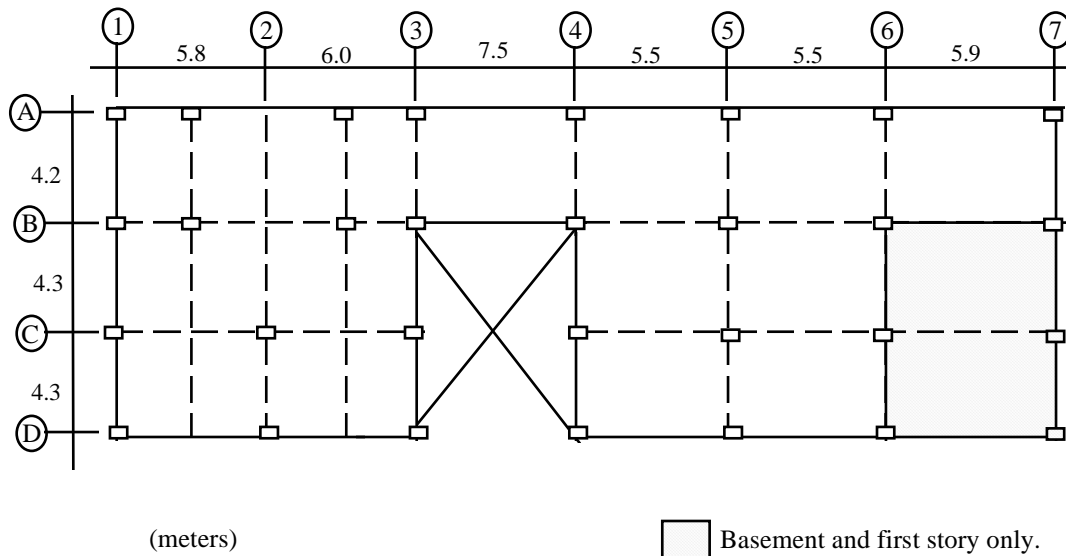

Figure 5.J1 Building plan.

Description of Damage After the 1985 Earthquake

The columns and the waffle slab were not damaged. The perimeter masonry walls on lines A and D and some of the partitions had minor cracks from story 1 to 3. Most of the plaster on walls was lightly cracked.

Although a structural review of the building indicated it was unnecessary to undertake a major rehabilitation, the owners made the decision to upgrade the building and achieve the seismic safety requirements of the 1985 Emergency Norms. This decision was induced by a feeling of insecurity on the part of the owners who were occupants of the building and witnessed severe damage and collapse of several medium-rise buildings in the neighborhood. Furthermore, cracking of the walls increased the owners' concern.

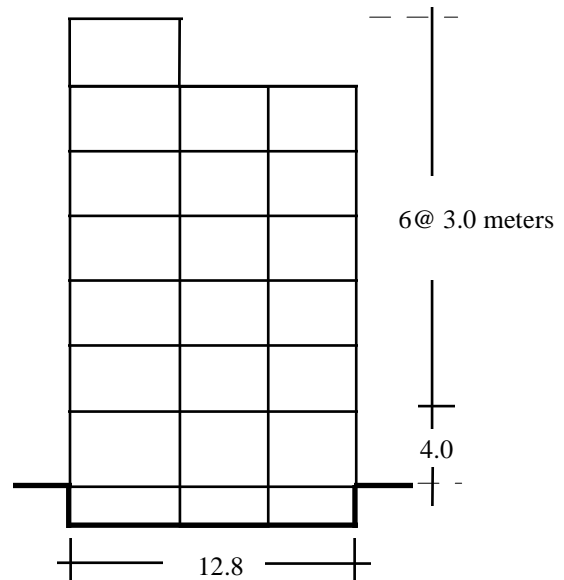

Figure 5.J2 Building elevation.

Temporary Measures

Since the structural members were not damaged, it was not necessary to shore the building, even during retrofitting work.

A retrofitting approach was developed to focus on increasing the stiffness of the structure, particularly in the short direction. The project consisted of adding steel bracing to four frames in the short direction, and strengthening the perimeter masonry walls with wire mesh and shotcrete in the long direction.

It was assumed that lateral loads in the short direction would be carried only by the braced frames, and vertical loads would be carried by the existing structure. The unbraced frames provided a second line of strength.

Also, it was assumed that the existing masonry would work monolithically with the reinforcement on its surface and would reach maximum capacity at the same time.

Strengthening Procedure

The steel bracing was placed on the middle of the frames on lines 1, 3, 4 and 6 from the ground floor to the roof (Fig. 5.J3). The steel braces were formed of two welded angles. The boundary columns were jacketed with steel angles at the corners by straps. Details of the bracing and jacketing are shown in Figures 5.J4 and 5.J5. The bracing elements

were added symmetrically to avoid torsional effects in the case of an earthquake during construction.

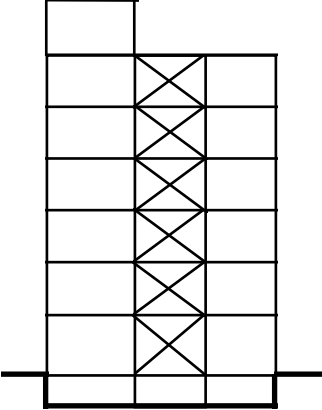
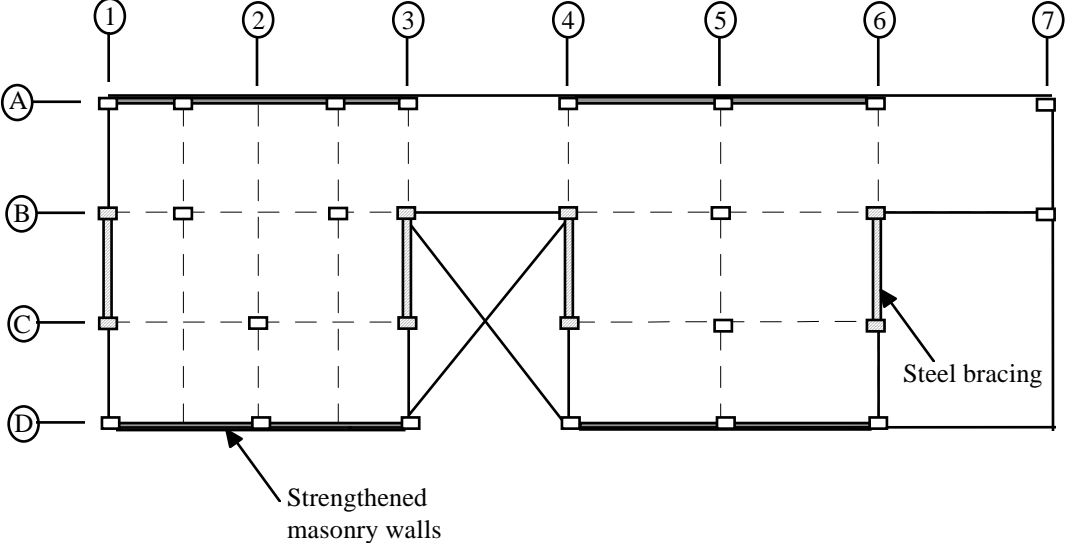

ELEVATION ON LINE 6

Figure 5.J3 Strengthening scheme.

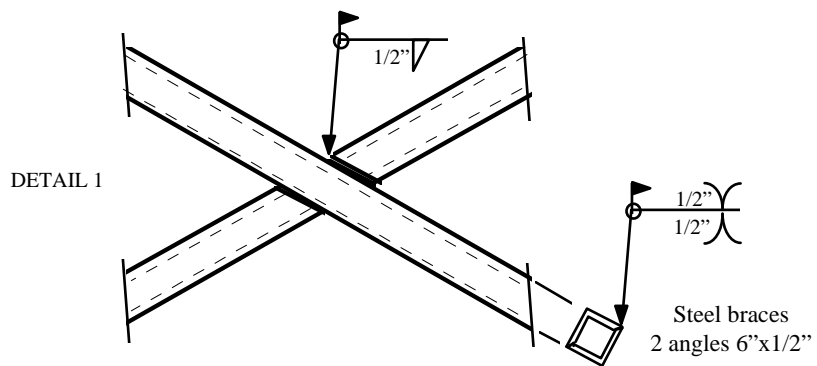
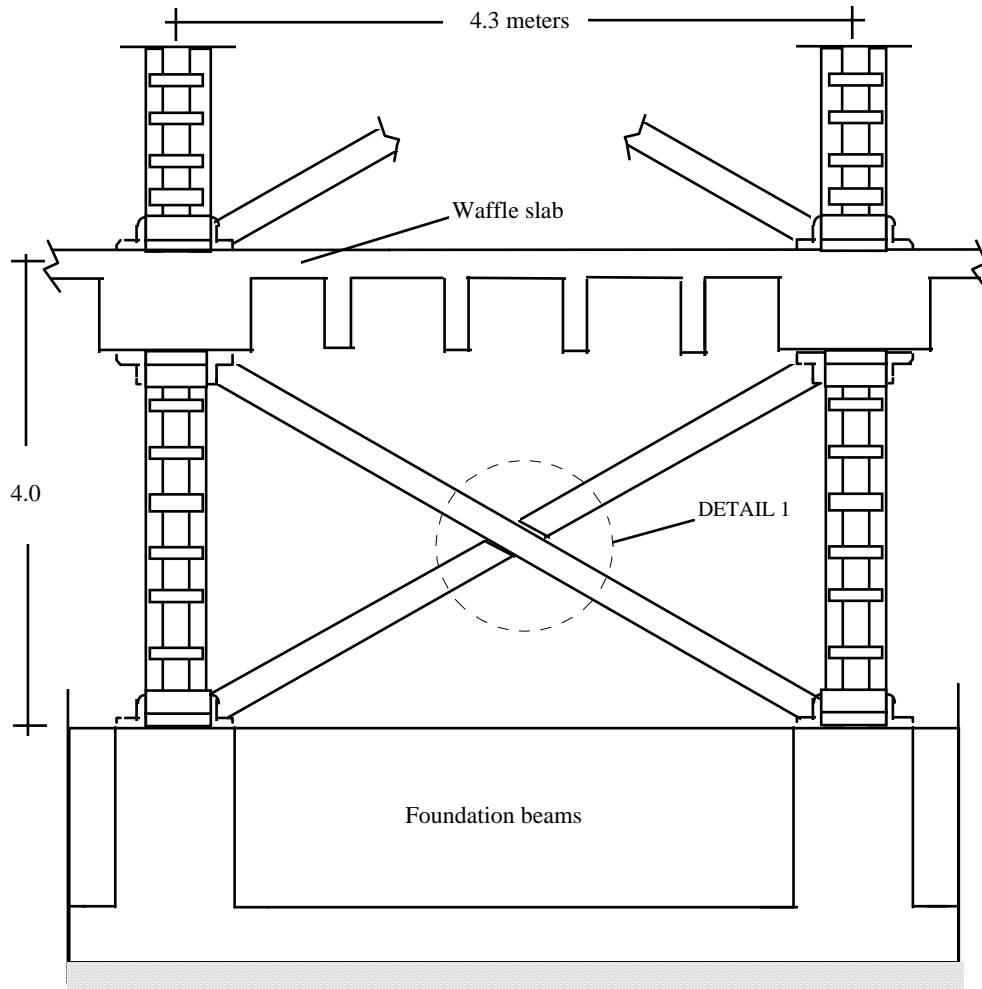
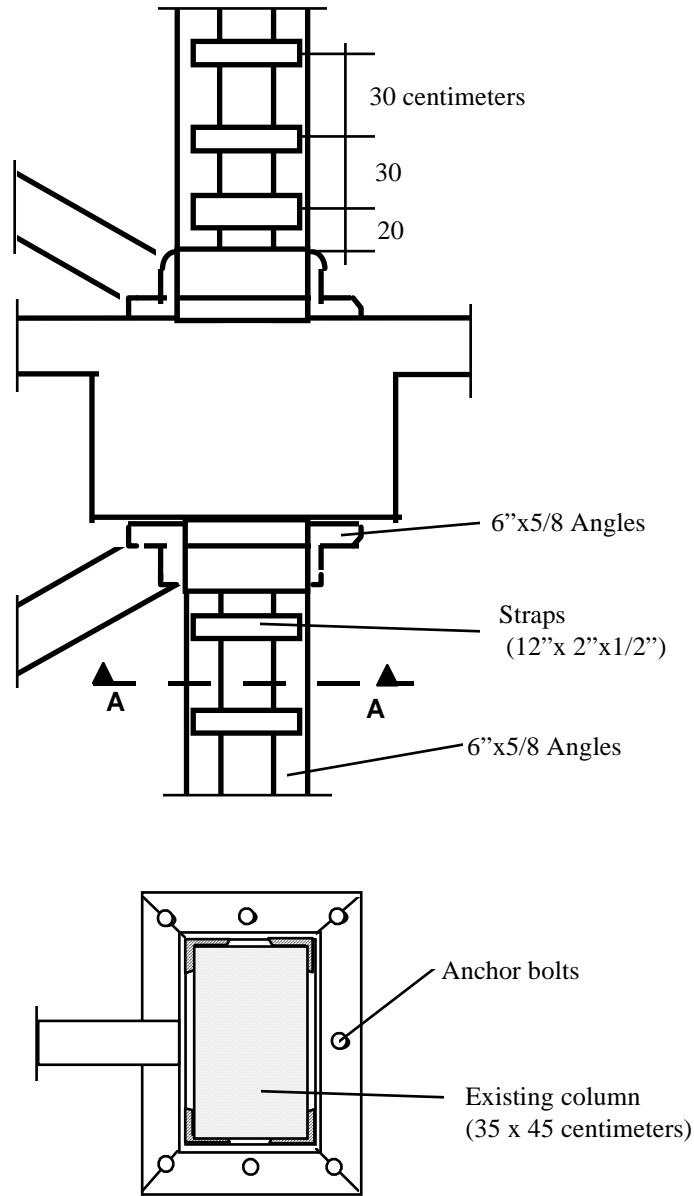

Figure 5.J4 Steel bracing.



SECTION A-A

Figure 5.J5 Column jacking details.

The masonry infill walls on lines A and D were strengthened by first filling all the cracks with a cement and sand (1:3) grout and an additive to control volume changes. The interior faces of the walls between axes 1 and 3, and 4 and 6 were covered with a welded wire mesh, fastened with 4" nails, and a layer of shotcrete. To anchor the mesh to the existing walls, new concrete boundary elements were built integrally with the new concrete cover (Fig. 5.J6).

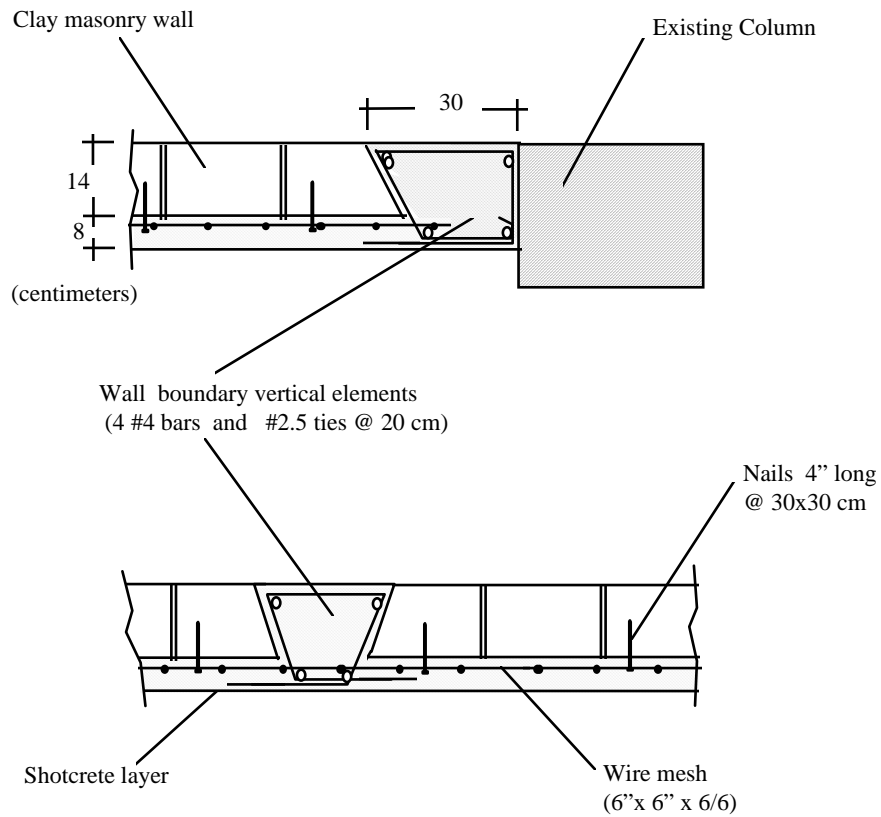

Figure 5.J6 Strengthening of boundary masonry infill walls.

The steel braces can be seen in Figures 5.J7 and 5.J8. The square elements attached in the center of the braces were added only for aesthetic purposes.

There were no modifications to the foundation system.



Figure 5.J7 Steel bracing in the building facade.



Figure 5.J8 Steel bracing in the upper levels.

5.11 BUILDING K

Building Description

The building was constructed in 1979-1980. It has 18 levels, divided into a basement for parking, ground floor, three more levels for parking, 12 levels of offices and a machine room (Fig. 5.K1 and 5.K2). The total area of construction is 21,946 m². The structure is formed of reinforced concrete columns with a waffle slab. The foundation is partially supported by piles. The building is located in the zone considered to be a transitional soil of the lake bed in Mexico City. There is a clay layer 18.5 m thick above the first hard layer of soil.

Description of Damage After the 1985 Earthquake

The structure had light damage due to the 1985 earthquake. The waffle slab's ribs showed many small cracks (<1 mm) in the region near the column axes and rigid zone around columns. Most of the damaged ribs were located in the upper stories. Damage was not observed in the columns.

After the earthquake a complete structural review of the building was done. The review included a comparison of the design drawings with the as-built condition. Also concrete core tests and measurements to check the verticality of the structure were carried out. Experimental vibration tests were used to determine the dynamic characteristics of the building.

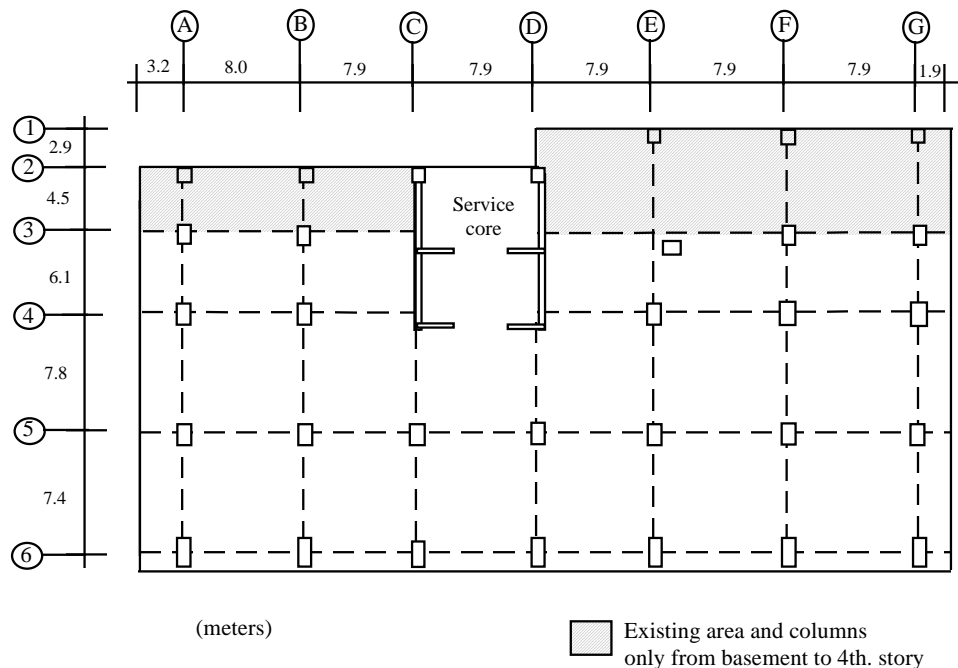

Figure 5.K1 Building plan.

The structural review indicated that there were eccentric slab-column connections that differed from the design drawings (Fig. 5.K3). Some tilting of the building was detected but there was not enough evidence to conclude that the problem was due to the earthquake. The report of the concrete core tests for the rigid zone (solid section near columns) of slabs showed that the actual concrete strengths were 60% higher than the nominal design strength and 20% higher for columns.

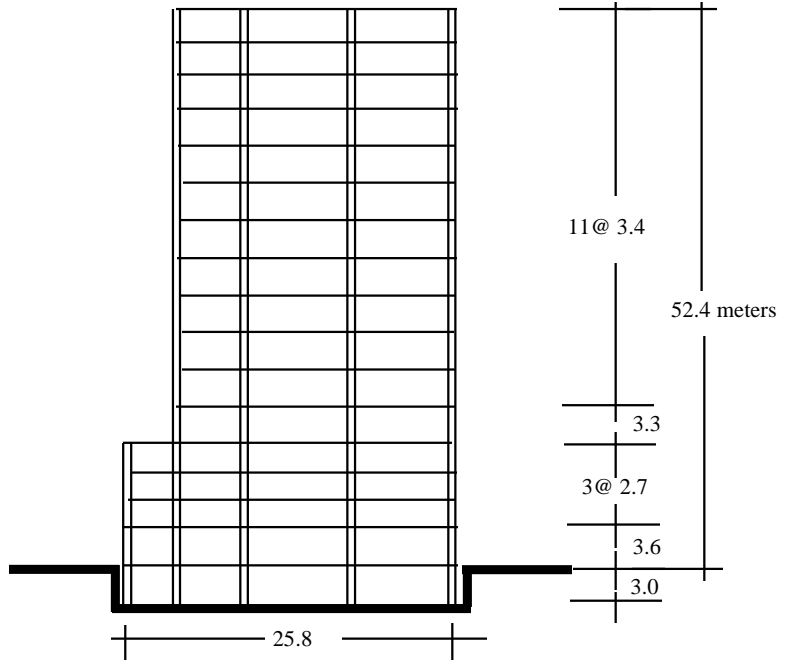

Figure 5.K2 Elevation on line A.

In addition to the vibration tests, a study of the properties of the soil was performed in order to obtain information for generating site spectra for the seismic analysis of the building.

Temporary Measures

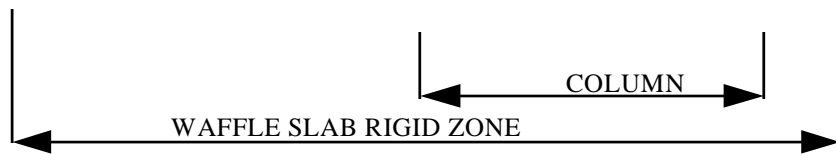

Figure 5.K3 Eccentric slab-column connection.

The building was reviewed to determine if it complied with the requirements of the Emergency Norms of 1985. It was analyzed using site spectra corresponding to the earthquake of September 19, 1985 and it was found that the structure did not comply with the safety levels required by the Emergency Norms.

On the basis of the results of the seismic analysis, recommendations were made for reinforcing the structure to increase its capacity to lateral loads. Different structural systems were analyzed for reinforcing the building to reduce seismic displacements and ductility demands. The following five alternatives were analyzed:

a. Shear wing walls at exterior grid lines.

This scheme involves adding reinforced concrete “wing walls” at the columns along lines A, G and 6 (Fig. 5.K1) in the 18 stories. Also exterior (or end) walls were added on lines A and G between axes 1 and 3. Lateral stability for these walls was provided by using triangular slabs anchored in the existing floor slabs in the 6th story and above (Fig. 5.K4).

b. Steel bracing.

In this alternative, steel braces were used to strengthen the building along lines A, G and 6 using steel bracing as shown in Figures 5.K5 and 5.K6.

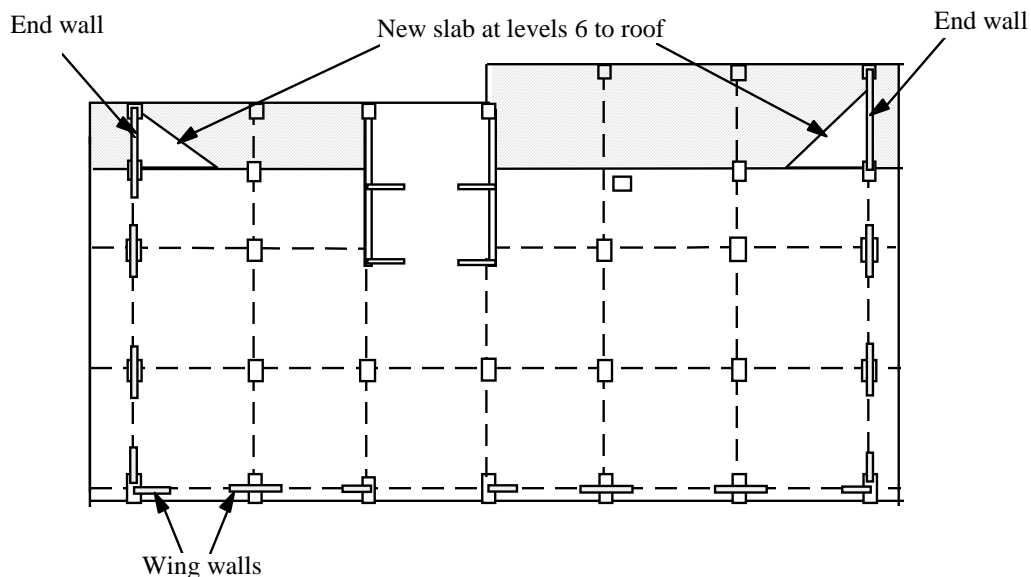

Figure 5.K4 Shear walls in exterior bays.

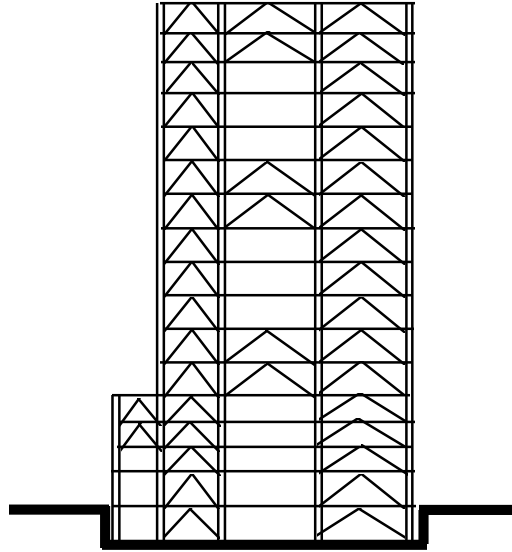

Figure 5.K5 Steel bracing on line A.

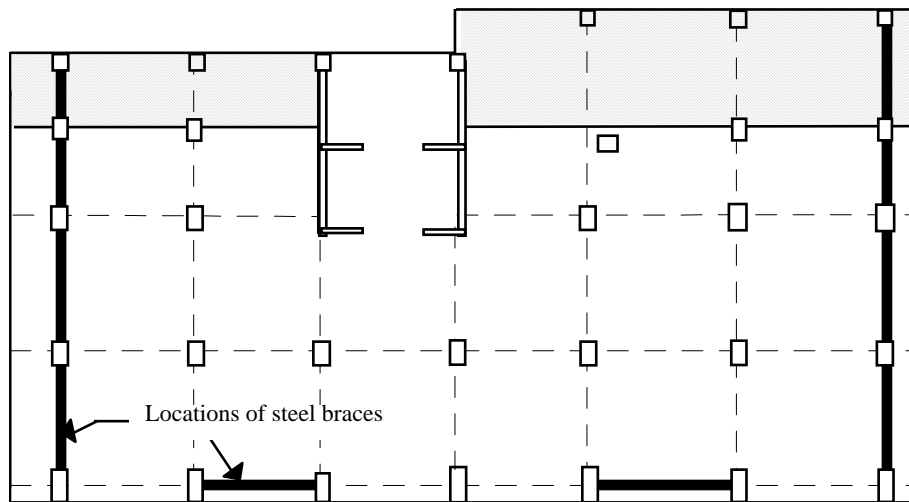

Figure 5.K6 Steel bracing alternative, plan view of brace locations.

c. Steel frames at exterior grid lines.

In this proposal steel frames were to be connected in parallel to the reinforced concrete frames at grids A and G.

d. Removal of upper floor levels.

This alternative consisted of removing the upper four levels of the building.

e. Steel girders over main frame lines.

The proposal consisted of placing steel girders along all main frame lines and connecting them to existing beams to create composite beams in both directions of the building.

f. “Macro-frames”.

The “Macro-frame” scheme consisted of developing large exterior frames by increasing the size of the existing columns and beams along the perimeter grid lines. Figure 5.K7 shows this alternative schematically.

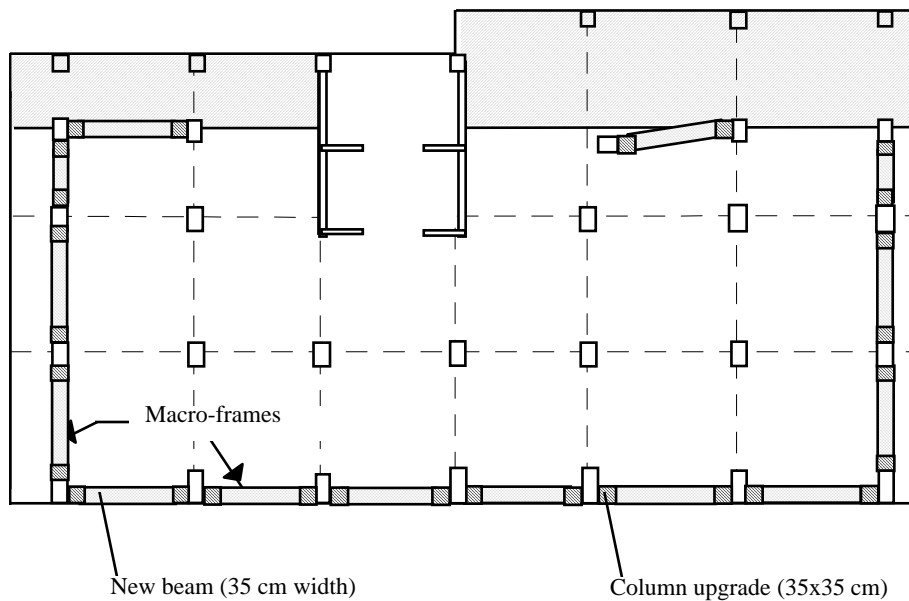

Figure 5.K7 Alternative of large perimeter frames.

For each of the six alternatives a representative structural model was analyzed under gravity loads and site ground motions, using a soil-structure interaction model. The ductility demands of the strengthened structure were compared with the existing structure. Also, the impact of the strengthening technique on the foundation was evaluated. The feasibility of constructing the strengthening technique was studied.

On the basis of the preliminary analysis, a technical cost evaluation of the different alternatives studied was completed in order to select the best project. A comparison of different parameters for each alternative is shown in Table 5.K1.

Alternative	Period ⁽¹⁾ sec.	Max. story drift ⁽²⁾ cm.	Additional piles needed	Estimated total cost ⁽³⁾ of reinforcement (dollars)
Original building	2.60	7.8 (15)	--	--
a. Wing walls	2.31	3.1 (15)	39	235,000
b. Steel bracing	1.86	3.6 (15)	14	241,000
c. Ext. Steel frames	2.30	6.5 (6)	0	1,157,000
d. Eliminating levels	1.87	6.8 (7)	0	350,000
e. "Macro frames"	1.87	2.0 (14)	18	391,000

⁽¹⁾Fundamental period

⁽²⁾Story Height = 410 cm. Number of story in brackets.

⁽³⁾The cost of labor and materials are based on values for 1988.

Table 5.K1 Results of preliminary analysis.

It was observed that the steel bracing and macro-frames option had several technical advantages related to other alternatives: lowest periods of vibration, considerable reduction in the ductility demands, reduction of story drift as well as fewer piles required.

The wing wall alternative was also satisfactory but it required more piles than the other schemes. Foundation modifications are a major construction problem in strengthening existing buildings. As a result of the studies, the steel braced frame was chosen as the system to be used because it combined the best economic and technical solutions.

Strengthening Procedure

The bracing system was designed with box sections, formed with two steel angles. Figure 5.K8 shows a typical steel brace at grids A, G and 6. The slab-column joints in the base of the steel braces were encased with steel plates above and below the floor (Fig. 5.K9). The steel elements were connected with the existing structure using high strength bolts.

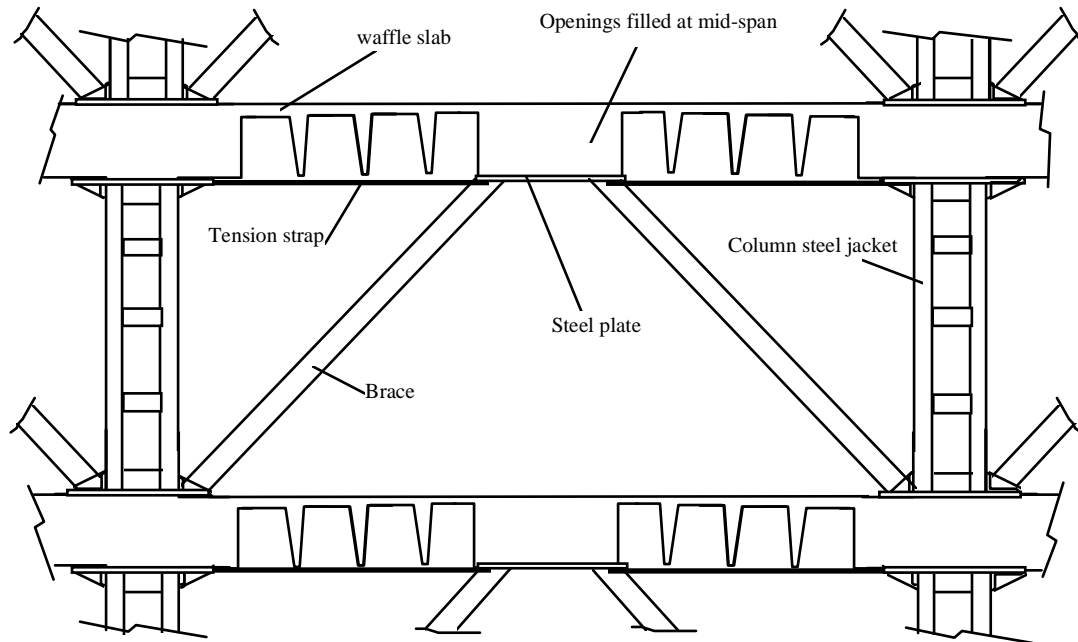

Figure 5.K8 Detail of the steel bracing system.

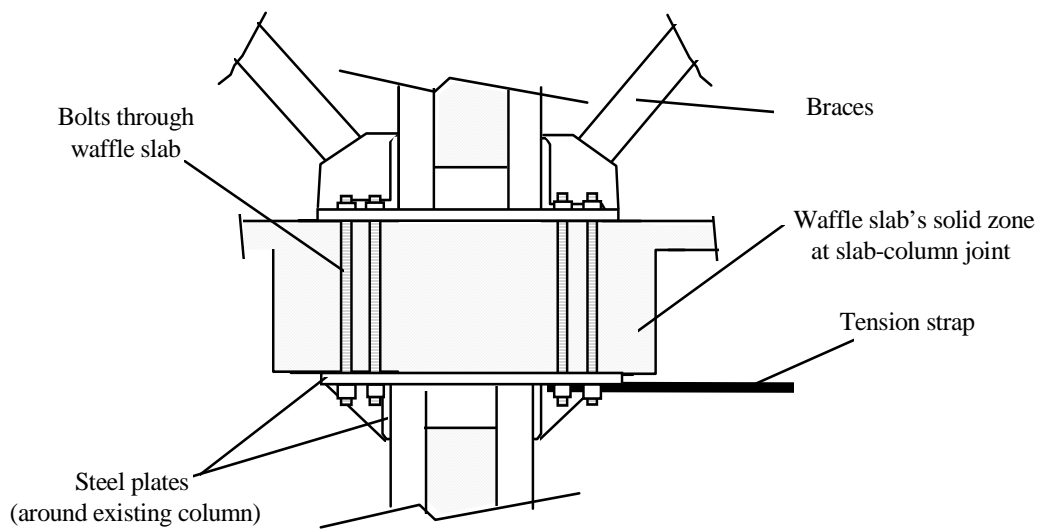

Figure 5.K9 Typical detail of brace connection at joints.

Steel jacking was used to reinforce the columns bounding the braced bays. At the midspan between columns where the braces are connected to the floor, the voids in the waffle slab were filled with reinforced concrete to create a solid zone with a steel plate below. The top of the jacketed columns was connected to the midspan steel plate by tension steel straps. A detail of the midspan connection is shown in Figure 5.K10.

The foundation was strengthened with new piles, 35 cm diameter and 19.5 m long, penetrating into the hard soil layer.

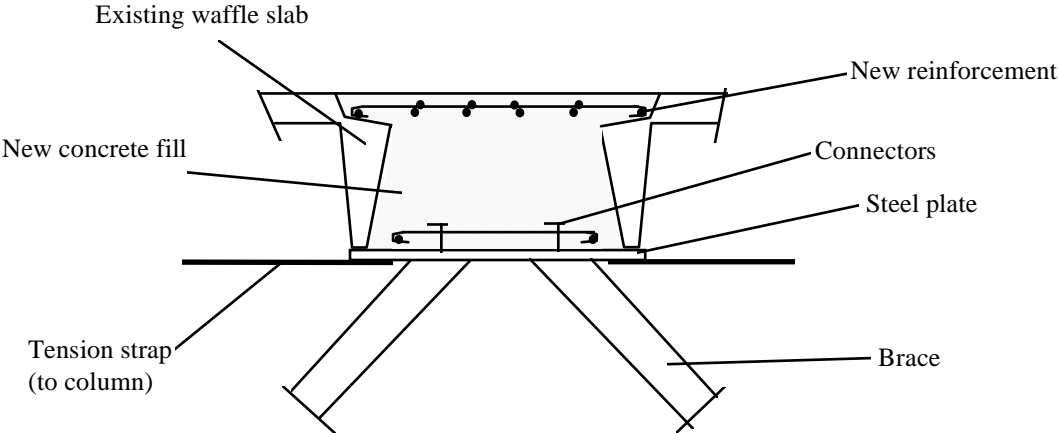

Figure 5.K10 Connection detail midway between columns.

5.12 BUILDING L

Building Description

The building is a reinforced concrete structure with fourteen floors and a basement. It is a long narrow building (1 bay by 7 bays) with an area approximately 420 m² per floor (Fig. 5.L1 and 5.L2). The structure consists of reinforced concrete frames with a solid concrete slab. The second floor (mezzanine) concrete slab is supported by steel beams in both directions. The foundation is partially supported by 26 m. long piles. The building is located in the lake bed zone of Mexico City.

In the 1957 earthquake, the building suffered severe structural damage to the columns. It was repaired and strengthened by increasing the size of some columns but without significant additional reinforcement. The exterior frame in column line 8 was stiffened with reinforced concrete braces and masonry infill walls as shown in Figure 5.L3.

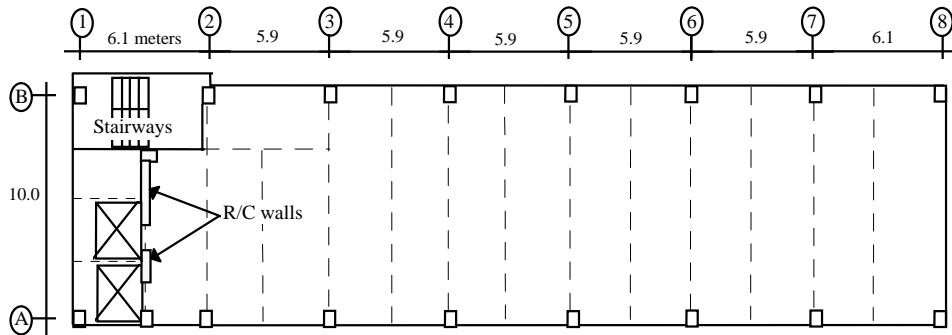

Figure 5.L1 Typical building plan.

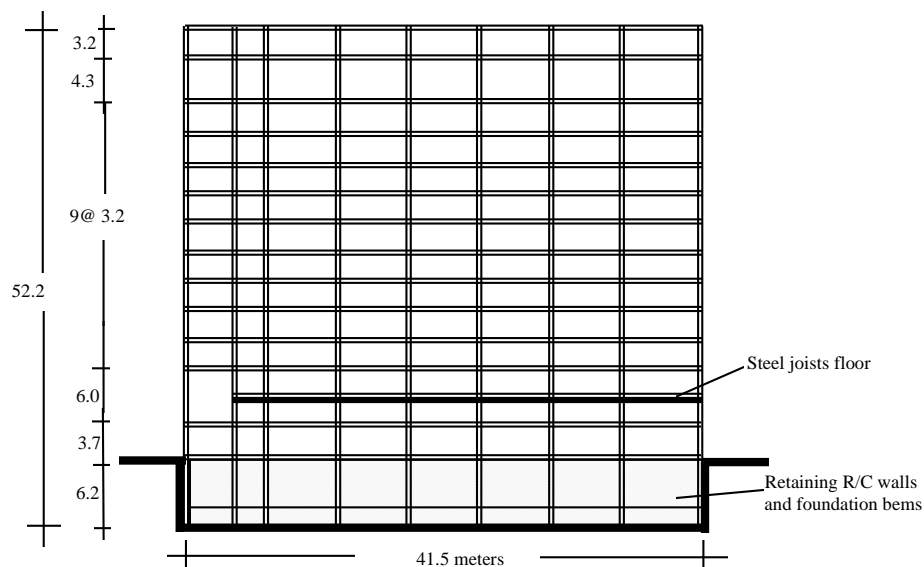

Figure 5.L2 Building elevation on line A.



Figure 5.L3 Existing concrete braces in column line 8.

Description of Damage After the 1985 Earthquake

The columns at lines 1 and 2 near the elevators suffered severe damage in all stories. The rest of the columns had lighter damage. The slab and beams were extensively cracked in all stories. The partition masonry walls had large cracks. The most damage was in the two top stories.

Temporary Measures

Following the 1985 earthquake, a structural review of the building recommended removal of the two upper levels of the building and removal of the floor finishes to reduce the weight of all the slabs. However, it was decided to develop a rehabilitation alternative which would increase the stiffness of the building without adding excessive mass or reducing the floor area. The strengthening approach consisted of installing a steel bracing system or walls and steel jacketing of beams and columns (Fig. 5.L4 and 5.L5).



Figure 5.L4 Steel braces in long direction (line A).



Figure 5.L5 Steel braces in short direction.

Strengthening Procedure

The frame on boundary line “B” which faced an adjacent building was strengthened with reinforced concrete walls and masonry infill walls in the five lower levels. The upper levels were stiffened with steel X-braces between lines 4-5 and 7-8 (Fig. 5.L6). Frame “A” which faced the street was strengthened with X-braces between lines 2-3, 4-5 and 6-7 in all the stories (Fig. 5.L7). A reinforced concrete wall was added between lines 1 and 1’ in all stories. The new wall was connected to column line 2 with coupling beams (Fig. 5.L8 and 5.L9).

In the short direction in frames 3,4,5 and 6, W-braces were constructed on alternate floors creating a staggered brace system as shown in Figure 5.L10.

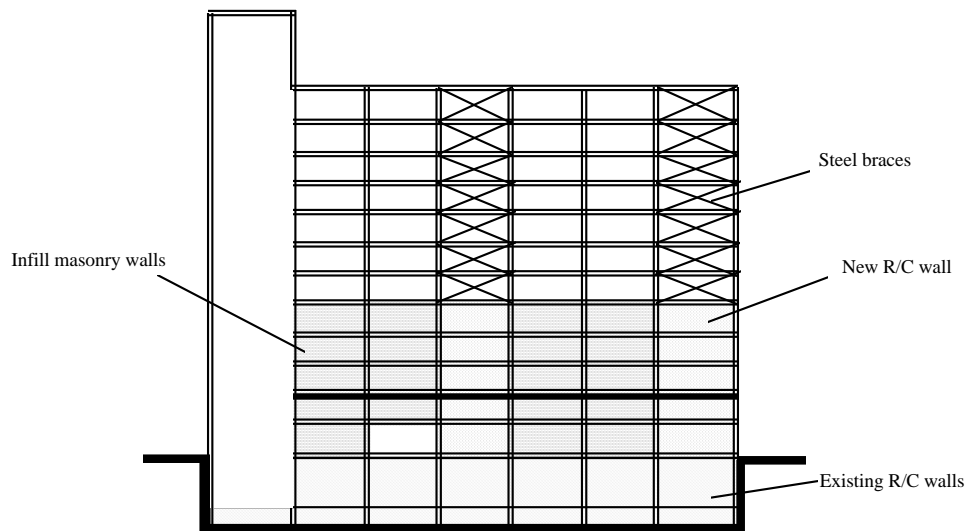

Figure 5.L6 Frame on line B.

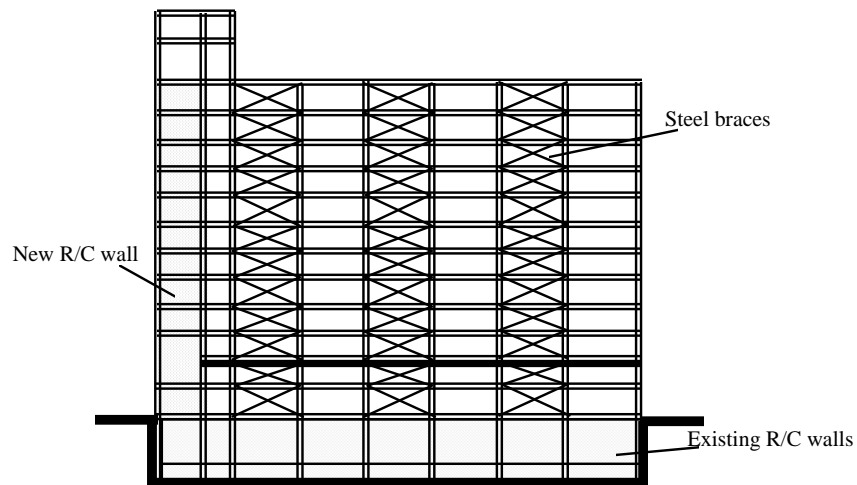

Figure 5.L7 Frame on line A.



Figure 5.L8 Reinforcement in new concrete wall.

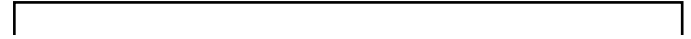

Figure 5.L9 Reinforced concrete wall in line A.

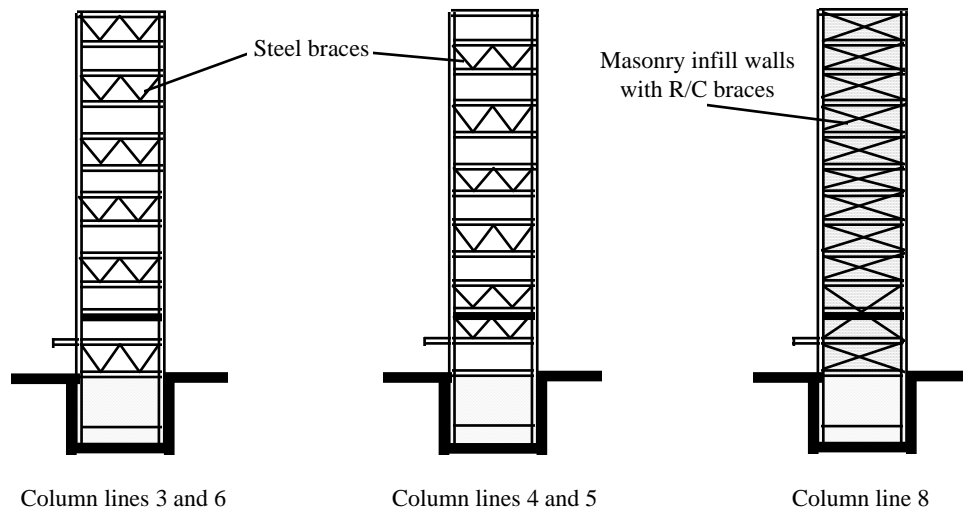

Figure 5.L10 Frames in short direction.

The connections between the braces and beams were made using steel base plates. The base plates were bolted to a steel box around the bottom of the beams as shown in Figures 5.L11 and 5.L12. The damaged concrete braces and masonry walls in line 8 were removed and rebuilt increasing the reinforcement in the braces (Fig. 5.L13). The masonry infill walls on line 1 were restored without changes.

Columns and beams along column lines were jacketed with steel elements and connected to the bracing system, as is shown in Fig. 5.L12 and 5.L14. The thickness of the slabs was increased with a reinforced concrete layer over the existing slabs in all floors. The new slab was attached to the existing slab using 1/2" steel connectors at 1 m. in both directions (Fig 5.L15).

Because of the changes in the superstructure, 56 new piles were added to the 26 existing piles and new foundation beams were constructed (Fig. 5.L16).

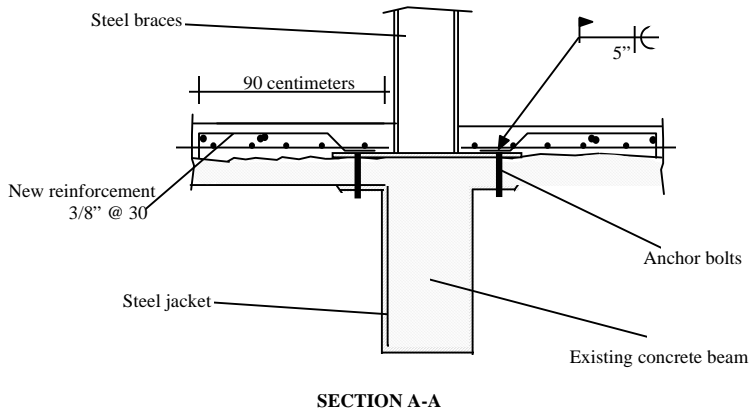
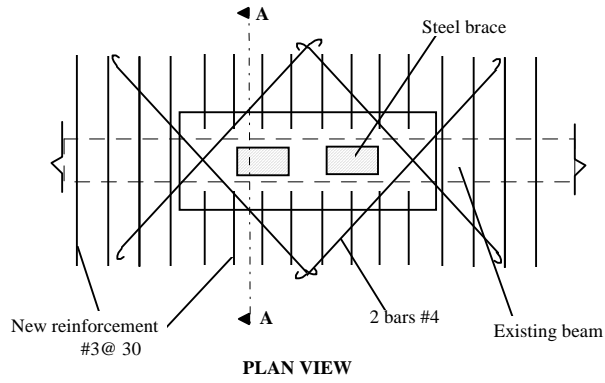

Figure 5.L11 Connection of steel braces to the existing beams.

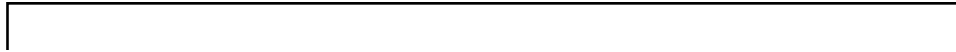

Figure 5.L12 Steel braces on line 6

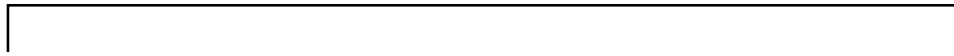

Figure 5.L13 Reinforced concrete braces on line 8.

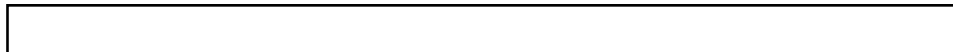

Figure 5.L14 Brace connection on lines 6 and A.

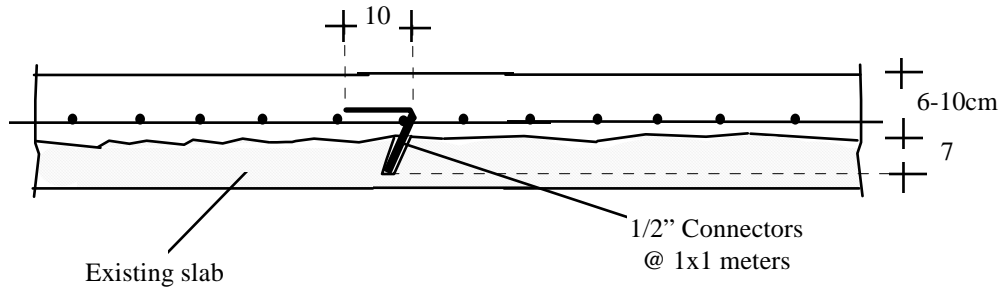

Figure 5.L15 Restoration of slabs

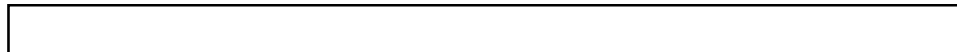

Figure 5.L16 Construction of new foundation beams.

CHAPTER 6

CONCLUSIONS

1. The uniqueness of the soil and the dynamic response of structures in Mexico City were an important factor in the solutions used in the Case Studies and may not be applicable elsewhere. Many of the rehabilitation projects were focused on taking the building out of the range of high amplification in the lake bed response spectra.
2. Damage studies are vital to design of a rehabilitation scheme. Causes of damage need to be understood to develop a proper rehabilitation. Earthquakes provide the best test of existing structures, and reconnaissance studies provide the basic information for identifying vulnerability of structures for future events.
3. Load paths for lateral forces must be clearly and carefully considered in designing the rehabilitation scheme. Critical elements in the load path are connections between new and existing elements, diaphragm capacity, foundations, location of shear walls and materials used. In some cases, modifications made following the 1979 earthquake produced eccentricities and discontinuities in the structural system that may have exacerbated damage in 1985. Local or partial repairs, without reasonable criteria, may produce more problems for a structure than leaving it in its original condition.
4. The strengthening schemes that resulted in a new load path substantially different from the original may demand significant upgrading of the foundations. Foundation modifications are an important economic factor to be considered in the assessment of a rehabilitation project. Comprehensive concrete jacketing of columns in medium rise buildings, with a high density of columns, is a rehabilitation alternative that may not demand major changes in the foundation. It has the disadvantage that it may reduce the building's space more than other options, such as shear walls or steel bracing. The addition of shear walls, in most cases, required the addition of piles. Although driving piles is expensive, it is relatively easy in soils like those of Mexico City but, in other soils, may be a complicated construction problem.
5. Occupancy may dictate the rehabilitation solution selected. The cost of disrupting operations may be much greater than the cost of construction. Some rehabilitation approaches were planned to disrupt only a portion of the building's occupants or operations. However, with few exceptions, this goal was not achieved. Rehabilitation construction operations are noisy, dusty and require access. As a result it is difficult for designers to anticipate all the problems inherent in this special kind of construction.
6. One of the main justifications for the differences between the 1985 earthquake response spectra and the Mexico City Code design response spectra was the addition of strict structural detailing requirements for use of ductility reduction factors (Q). This argument may not be applicable for rehabilitation projects because the deformation compatibility between new and existing elements can produce a structural behavior much different from that expected in new structures, even when the new elements meet

the ductility requirements of the Code. The Code does not distinguish between design of new and existing structures and the ductility factors appear to be high for some rehabilitation projects.

7. The current Code requires damaged buildings and Importance Group A buildings to be designed to current standards. Otherwise, the structural capacity does not need to be changed from that of the code under which it was designed. Programs to evaluate undamaged existing buildings and qualified project supervision, as those described in Chapter 3, must continue in Mexico City and in other urban areas located in seismic zones around the world if seismic hazards are to be effectively reduced.

8. Documentation of rehabilitation projects is needed all over the world so that when earthquakes strike rehabilitated buildings, performance can be studied in considerable detail. Structural engineers need to continue to learn from experience and to share information. This report was possible because of the open disposition of Mexican structural engineers to share their experiences with Mexican and American researchers.

BIBLIOGRAPHY

- Badoux, M. and Jirsa J., "Retrofitting of Reinforced Concrete Structures with Steel Bracing Systems", Proceedings of the IABSE Symposium, Paris, 1987, pp. 447-454.
- Brena, S. F., "An Overview of Rehabilitation Techniques Used in Reinforced Concrete Buildings in Mexico City", Thesis presented to the Graduate School of the University of Texas at Austin in Partial Fulfillment of the Requirements for the Degree of Master of Science in Engineering, The University of Texas at Austin, December 1990.
- Del Valle, E., "Some Lessons Learned from the March 14 Earthquake in Mexico City", Seventh World Conference on Earthquake Engineering, Vol. 4, Istanbul, Turkey, 1980, pp. 545-552.
- Departamento del Distrito Federal, "Reglamento de Construcciones para el Distrito Federal", Gaceta Oficial, Vol. II, No. 218, Mexico City, August 1993.
- Esteva, L., "The Practice of Earthquake Engineering in Mexico City and its Revision in the Light of the Observations from the 1985 Earthquakes", Proceedings of the Third U.S. National Conference on Earthquake Engineering, Charleston, S.C., 1986, Vol. IV, pp. 2553-2573.
- Fundacion ICA, A.C., "Experiencias derivadas de los sismos de septiembre de 1985", Limusa, Mexico, D.F., 1988.
- Girault, P., "Analyses of Foundation Failures", The Mexico Earthquakes-1985: Factors Involved and Lessons Learned, ASCE, 1987, pp. 178-192.
- Iglesias, J. and Aguilar, J., "Identificacion de Danos Ocasionados por los Sismos de 1985, 1979 y 1957 en la Zona Metropolitana", Estudios de Sismicidad en el Valle de Mexico, 3a Parte, Capitulo III, Anexos I and II, Departamento del Distrito Federal and Centro de las Naciones Unidas para los Asentamientos Humanos (HABITAT), Mexico, D.F., 1988.
- Iglesias, J., Robles, F., De La Cera, J. and Gonzalez, O., "Reparacion de estructuras de concreto y mamposteria", Universidad Autonoma Metropolitana, Mexico, D.F., 1988.
- Iglesias, J., "The Mexico Earthquake of September 19, 1985 -Seismic Zoning of Mexico City after the 1985 Earthquake", Earthquake Spectra, Earthquake Engineering Research Institute, Vol. 5, No. 1, February 1989, PP. 257-271.

- Lermo, J., Rodriguez M. and Singh, S., "The Mexico Earthquake of September 19, 1985 Natural Period of Sites in the Valley of Mexico from Microtremor Measurements and Strong Motion Data", Earthquake Spectra, Earthquake Engineering Research Institute, Vol. 4, No. 4, November 1988, pp. 805-814.
- Marsal, R., "Geotechnical Notes on the Effects of Mexico's 1985 Earthquakes", The Mexico Earthquakes-1985: Factors Involved and Lessons Learned, ASCE, 1987, pp. 78-95.
- Meli, R., "Evaluation of Performance of Concrete Buildings Damaged by the September 19, 1985 Mexico Earthquake", The Mexico Earthquakes-1985: Factors Involved and Lessons Learned, ASCE, 1987, pp. 308-327.
- Mena, E., et. al., "Acelerograma en el centro SCOP de la Secretaria de Comunicaciones y Transportes. Sismo del 19 de septiembre de 1985", Informe IPS-10B, Instituto de Ingenieria, UNAM, 1985.
- Moore, J., "Dry and Wet Mix Process Shotcrete", Concrete Construction, November, 1987, pp. 629-630.
- Murray, M., "Welding Cracked Concrete with Epoxy Injection", Plant Engineering, October 1981, pp. 133-135.
- Norena, F., Castaneda, C. and Iglesias, J., "The Mexico Earthquake of September 19, 1985 Evaluation of the Seismic Capacity of Buildings in Mexico City", Earthquake Spectra, Earthquake Engineering Research Institute, Vol. 5, No. 1, February 1989, pp. 19-24.
- Rosenblueth, E. and Meli, R., "The 1985 Earthquake: Causes and Effects in Mexico City", Concrete International, May 1986, pp. 23-34.
- Rosenblueth, E., "Emergency Regulations and the New Building Code", The Mexico Earthquakes-1985: Factors Involved and Lessons Learned, ASCE, 1987.
- Seed, B., Romo, M., Sun, J., Jaime A., and Lysmer J., "Relationships Between Soil Conditions and Earthquake Ground Motions in Mexico City in the Earthquake of Sept. 19, 1985", Report No. UCB/EERC-87/15, University of California, Berkeley, October 1987.
- Sugano, S. and Endo T., "Seismic Strengthening of Reinforced Concrete Buildings in Japan", paper presented at IASBE Symposium, Venetia, 1983.
- Teran, A., "Review of Repair Techniques for Earthquake Damaged Reinforced Concrete Buildings", Thesis presented to the Graduate School of the University of Texas at Austin in Partial Fulfillment of the Requirements for the Degree of Master of Science in Engineering, The University of Texas at Austin, December 1988.

Whitman, R., "Are the Soil Depositions in Mexico City Unique?", The Mexico Earthquakes-1985: Factors Involved and Lessons Learned, ASCE, 1987, pp. 163-177.

Wiener, D. and Jirsa, J., "Attaching Steel Members to Reinforced Concrete Elements", Dynamic Response of Structures, ASCE, 1986, pp. 302-309.

Zeevaert, L., "Foundation Engineering for Difficult Subsoil Conditions", Second Edition, Van Nostrand Reinhold, New York, 1983.

VITA

Jorge Alfredo Aguilar was born in Comitán, Chiapas, Mexico on September 16, 1962, the son of Javier Aguilar and Blanca Carboney. After completing his high-school studies at "Preparatoria de Comitán", he entered "Universidad Autónoma Metropolitana"(UAM) in Mexico City in 1981. He received the degree of Bachelor of Science in Civil Engineering from UAM in April 1986. In 1986, he joined the consultant firm "CANDE, Ingenieros" of Mexico City as assistant engineer. In 1990, he joined the insurance company "Seguros America" of Mexico City as head of the Section of Catastrophic Risks. Since 1988 he has worked on a part-time basis for UAM as Assistant Professor. In 1992, he became Associate Professor and Researcher of the Area of Structures of UAM. During his work at UAM he has been involved in several research projects focused on rehabilitation and evaluation of existing structures, and seismic instrumentation. In August 1994, he entered The Graduate School at the University of Texas at Austin.

Permanent Address: Av. Coyoacán #1625 -139
 Mexico D.F.
 03100 Mexico.

This thesis was typed by the author.