

**BEHAVIOR OF SHEAR ANCHORS IN CONCRETE:  
STATISTICAL ANALYSIS AND DESIGN  
RECOMMENDATIONS**

**by**

**Hakki Muratli, B.S.**

**Thesis**

Presented to the Faculty of the Graduate School of  
The University of Texas at Austin  
in Partial Fulfillment  
of the Requirements  
for the Degree of

**Master of Science in Engineering**

**The University of Texas at Austin**

**May 1998**

**BEHAVIOR OF SHEAR ANCHORS IN CONCRETE:  
STATISTICAL ANALYSIS AND DESIGN  
RECOMMENDATIONS**

**Approved by  
Supervising Committee:**

---

Richard E. Klingner

---

Ned H. Burns



## **ACKNOWLEDGMENTS**

First I would like to thank the sponsor of this research program, US Nuclear Regulatory Commission, for their support of this research.

Dr. Richard E. Klingner, my advisor, deserves many thanks for his guidance and patience during the research program and throughout my graduate education.

I would also like to thank Mansour Shirvani for his assistance throughout all phases of the research and during the writing of the thesis.

Finally I am grateful to my family for their love, encouragement and support.

Hakki Muratli

May 1998

Austin, TX

## **DISCLAIMER**

This thesis presents partial results of a research program supported by the U.S. Nuclear Regulatory Commission (NRC) under contract No. NRC-04-96-059. The technical contact is Herman L. Graves, III. Any conclusions expressed in this thesis are those of the author. They are not to be considered as NRC recommendations or policy.

## **ABSTRACT**

# **BEHAVIOR OF SHEAR ANCHORS IN CONCRETE: STATISTICAL ANALYSIS AND DESIGN RECOMMENDATIONS**

Hakki Muratli, M.S.E.

The University of Texas at Austin, 1998

Supervisor: Richard E. Klingner

The overall objective of this thesis is to examine the shear behavior of anchors in uncracked and cracked concrete under static and dynamic loading, and based on that examination to propose procedures for designing and evaluating such anchors.

The first task is to summarize the basic principles and the design guidelines in documents like ACI 318 (Building Code Requirements for Structural Concrete, anchorage proposal, Chapter 23), the draft ACI 349 (Code Requirements for Nuclear Safety Related Structures, Chapter 23), USI A-46 SQUG Report (Unresolved Safety Issues Seismic Qualification Utility Group Report), and the ACI 355 State of the Art Report. The next step is to establish a

database of existing data on shear anchors using the same general principles previously used for a similar tensile database.

The second task is to compare the test data with predictive equations of different methods (such as the CC Method and 45-Degree Cone Method) for computing anchor capacity as limited by concrete breakout.

The third task is to evaluate the trends in test data. Initial evaluations are made using linear regression analysis. Final evaluations are made using Load and Resistance Factor Design (LRFD) principles.

The fourth and final task is to recommend design and evaluation procedures based on that evaluation.

## TABLE OF CONTENTS

CHAPTER ONE.....	1
INTRODUCTION.....	1
1.1 Introduction .....	1
1.2 Objective and Scope of the Overall Project .....	2
1.3 Objective and Scope of Thesis .....	3
CHAPTER TWO.....	5
BACKGROUND: BEHAVIOR AND DESIGN OF CONNECTIONS TO CONCRETE .....	5
2.1 Introduction .....	5
2.2 Definition and Classification of Anchors.....	5
2.2.1 Cast-In-Place Anchors.....	6
2.2.2 Post-Installed Anchors .....	6
2.2.3. Definition of Embedment Depth .....	9
2.3 Behavior of Single-Anchor Connections to Concrete under Shear Loading.....	11
2.3.1 Failure Modes and Failure Loads in Shear .....	11
2.3.2 Load-Displacement Curves of Anchors in Shear .....	19
2.4 Current Design Guidelines .....	20
2.4.1 ACI 318 (Anchorage Proposal, Appendix F of this thesis).....	21
2.4.2 ACI 349 (Chapter 23 Draft, Appendix G of this thesis) .....	21
2.4.3 USI A-46, SQUG Report .....	23
2.4.4 ACI 355 State of the Art Report.....	35
CHAPTER THREE.....	36
EVALUATION OF SHEAR BREAKOUT DATA .....	36
3.1 Introduction .....	36
3.2 Criteria in Compilation and Evaluation of Database .....	37
3.3 Proposed Capacities for Design of Shear Anchors .....	39



3.4 Shear Breakout Data for Single and Double Anchors in Uncracked Concrete under Static Loading .....	41
3.5 Single Anchors in Cracked Concrete under Static Shear Loading .....	44
3.6 Single Anchors in Uncracked Concrete under Dynamic Shear Loading.....	46
3.7 Single Anchors in Cracked Concrete under Dynamic Shear Loading ...	48
3.8 Alternative Formula Based on Regression Analysis.....	50
3.8 Summary of Observations and Evaluations .....	61
CHAPTER FOUR.....	67
STATISTICAL EVALUATION OF DATABASE .....	67
USING A DUCTILE DESIGN APPROACH.....	67
4.1 Introduction .....	67
4.2 Basic Assumptions And Steps In Probability Analysis .....	67
4.3 General Limitations of the Statistical Analysis.....	76
CHAPTER FIVE.....	77
SUMMARY, CONCLUSIONS, AND RECOMMENDATIONS .....	77
5.1 Summary .....	77
5.2 Conclusions from Statistical Analysis.....	78
5.3 Recommendations for Design and Evaluation .....	78
5.3 Recommendations for Future Research .....	80
APPENDIX A: Static Shear Load Data in Uncracked Concrete .....	79
APPENDIX B: Static Shear Load Data in Cracked Concrete .....	106
APPENDIX C: Dynamic Shear Load Data in Uncracked Concrete.....	109
APPENDIX D: Dynamic Shear Load Data in Cracked Concrete.....	112
APPENDIX E: Tension and Shear Tests on Anchor Steel .....	115
APPENDIX F: The Draft Proposal for ACI 318 Chapter 23 .....	123
APPENDIX G: The Draft Proposal for ACI 349 Chapter 23 .....	145

REFERENCES.....	175
VITA .....	181

## LIST OF FIGURES

Figure 2. 1 Typical Cast-In-Place Anchors .....	6
Figure 2. 2 Expansion Anchors .....	7
Figure 2. 3 Undercut Anchors .....	8
Figure 2. 4 Grouted Anchor .....	9
Figure 2. 5 Demonstration of Anchor Embedment Depths.....	10
Figure 2. 6 An Anchor Loaded in Shear .....	11
Figure 2. 7 Lateral Concrete Cone Failure.....	13
Figure 2. 8 Idealized Shape of Shear Breakout Cone of a Single Anchor .....	14
Figure 2. 9 Projected Areas for Shear Anchors According to 45-Degree Cone Method .....	15
Figure 2. 10 Idealized Design Model for a Single Anchor Under Shear in CC Method .....	16
Figure 2. 11 Projected Areas for Shear Anchors in Thin Members According to CC Method .....	17
Figure 2. 12 Pryout Cone Failure .....	19
Figure 2. 13 Typical Load-Displacement Curves of Anchors in Shear .....	20
Figure 3. 1 Ratios of Observed to Predicted Concrete Shear Breakout Capacities, CC Method (File: shear.xls, Sheet: s-1-u-s).....	42
Figure 3. 2 Ratios of Observed to Predicted Concrete Shear Breakout Capacities, 45-Degree Cone Method (File: shear.xls, Sheet: s-1-u-s).....	43
Figure 3. 3 Ratios of Observed to Predicted Concrete Shear Breakout Capacities, CC Method (File: shear.xls, Sheet: s-1-c-s).....	45
Figure 3. 4 Ratios of Observed to Predicted Concrete Shear Breakout Capacities, 45-Degree Cone Method (File: shear.xls, Sheet: s-1-c-s).....	45
Figure 3. 5 Ratios of Observed to Predicted Concrete Shear Breakout Capacities, CC Method (File: shear.xls, Sheet: s-1-u-d) .....	46

Figure 3. 6 Ratios of Observed to Predicted Concrete Shear Breakout Capacities, 45-Degree Cone Method (File: shear.xls, Sheet: s-1-u-d) .....	47
Figure 3. 7 Ratios of Observed to Predicted Concrete Shear Breakout Capacities, CC Method (File: shear.xls, Sheet: s-1-c-d).....	48
Figure 3. 8 Ratios of Observed to Predicted Concrete Shear Breakout Capacities, 45-Degree Cone Method (File: shear.xls, Sheet: s-1-c-d).....	49
Figure 3. 9 Ratios of Observed to Predicted Concrete Shear Breakout Capacities, Regression Formula (file: shear.xls Sheet: Regression) .....	53
Figure 3. 10 Comparison of Mean Values for ( $V_{obs}/V_{pred}$ ) for Different Methods	55
Figure 3. 11 Comparison of Coefficient of Variation for ( $V_{obs}/V_{pred}$ ) for Different Methods.....	56
Figure 3. 12 Ratios of Observed to Predicted Concrete Shear Breakout Capacities, for Single Cast-in-Place Anchors using CC Method (file: shear.xls) .....	56
Figure 3. 13 Ratios of Observed to Predicted Concrete Shear Breakout Capacities, for Single and Double Post-Installed Anchors using CC Method (file: shear.xls) .....	58
Figure 3.14 Ratios of Observed to Predicted Concrete Shear Breakout Capacities, for Single Cast-in-Place Anchors using 45-Degree Cone Method (file: shear.xls) .....	57
Figure 3.15 Ratios of Observed to Predicted Concrete Shear Breakout Capacities, for Single and Double Post-Installed Anchors using 45-Degree Cone Method (file: shear.xls).....	58
Figure 3.16 Ratios of Observed to Predicted Concrete Shear Breakout Capacities, for Single Cast-in-Place Anchors using Regression Formula (file: shear.xls)	59
Figure 3.17 Ratios of Observed to Predicted Concrete Shear Breakout Capacities, for Single and Double Post-Installed Anchors using Regression Formula (File: shear.xls).....	60
Figure 4. 1 Probabilities of Failure under Known Loads.....	75

Figure 4. 2 Probabilities of Brittle Failure Independent of Load .....	75
--	----

### LIST OF TABLES

Table 3. 1 Normalization Constant “k” and corresponding $\phi$ -factor for Different Design Approaches .....	40
Table 3.2 Results of Multivariate Regression Analysis (File: shear.xls Sheet: Regression).....	51
Table 3.3 Summary of Regression Statistics.....	52
Table 3.4 Summary of T Statistics .....	52
Table 3.5 Modifications on Normalization Constant “k” and corresponding $\phi$ -factors for Different Design Approaches .....	64
Table 4. 1 Probabilities of Brittle Failure under Known Loads for Different Categories of Shear Anchors, Ductile Design Approach.....	74
Table 4. 2 Probabilities of Brittle Failure Independent of Load for Different Categories of Shear Anchors, Ductile Design Approach.....	74

## **CHAPTER ONE**

### **INTRODUCTION**

#### **1.1 INTRODUCTION**

Anchors are widely used to attach structural and nonstructural elements to concrete in nuclear, highway and building construction. However, the behavior of anchors and anchor connections is still not fully understood.

Nuclear power plants are one of the major construction types in which anchors are used to attach mechanical and electrical equipment. It is necessary to ensure that the anchors supporting such critical equipment can resist both static and dynamic loads. Moreover, concrete structures may have cracks due to various reasons such as restrained thermal movements and shrinkage.

Therefore it is very important to understand the behavior of connections under various loading conditions, in order to be able to design them safely and reasonably.

## **1.2 OBJECTIVE AND SCOPE OF THE OVERALL PROJECT**

In recognition of these issues, the US Nuclear Regulatory Commission (NRC) sponsored a research project at the University of Texas at Austin. The objective of the project is to provide the US Nuclear Regulatory Commission with a comprehensive document that can be used to establish regulatory positions regarding anchorage to concrete. The project consists of 3 tasks:

Task 1: To prepare a report which summarizes the guidance in documents such as:

- 1) ACI 318 “Building Code Requirements for Structural Concrete”  
(Appendix G of this thesis)
- 2) ACI 349 “Code Requirements for Nuclear Safety Related Structures”  
(Appendix F of this thesis)
- 3) USI A-46 SQUG Report “Unresolved Safety Issues Seismic Qualification Utility Group Report”
- 4) ACI 355 State-of-the-Art Report.

The report will cover major design documents in use for the design, analysis and testing of anchors.

Task 2: To review and evaluate available sources of test data for tensile and shear loading to establish trends in test results.

Task 3: To prepare a comprehensive report which covers all aspects of anchorage design such as single bolt behavior, group bolt behavior, edge conditions, cracked concrete performance, load considerations (static and dynamic).

### **1.3 OBJECTIVE AND SCOPE OF THESIS**

This thesis addresses the above tasks. First, the basic principles and design guidelines in ACI 318 (anchorage proposal), ACI 349 (Chapter 23), USI A-46 SQUG Report, and the ACI 355 State of the Art Report are summarized. Then the shear behavior of anchors in uncracked and cracked concrete under static and dynamic loading is evaluated based on a database of test results. Finally recommendations for the design of shear anchors are made and some modifications are proposed for the effects of dynamic loading, cracking, anchor type and some changes in formulas for estimating shear capacity as governed by concrete breakout.

Over the past several years, technical committees on anchorage to concrete have begun to agree on basic trends of behavior of tensile anchors. This growing consensus relies on an accepted database of test results for tensile anchors. In contrast, there is no such consensus database for shear anchors. Therefore, one objective of this thesis is:

- to establish a database for shear anchors using the same principles previously applied to the tensile database;



- to compare the test data with predictive equations of the CC Method and 45-Degree Cone Method for computing anchorage capacity as limited by concrete; and
- to evaluate trends in test data.

The following cases are included:

- 1) single anchors far from edges;
- 2) edge effects;
- 3) effect of static and dynamic loading; and
- 4) effect of cracks.

Initial evaluations are made using linear regression analysis. Final comparisons are made using probabilistic simulation (First Order Reliability Method) and Load and Resistance Factor Design (LRFD) principles.

## **CHAPTER TWO**

### **BACKGROUND: BEHAVIOR AND DESIGN OF CONNECTIONS TO CONCRETE**

#### **2.1 INTRODUCTION**

Anchors connect structural members and equipment to concrete or masonry. Tensile and shear loads are transferred between concrete and attachment through the anchor. This chapter is taken from Zhang (1997), and presents background material on types of anchors and behavior and failure modes of single anchors in shear. The design methodology is discussed with reference to 45-Degree Cone Method and the Concrete Capacity Method.

#### **2.2 DEFINITION AND CLASSIFICATION OF ANCHORS**

Loads on attachments are transferred into the base concrete through anchors as concentrated loads, by friction, mechanical interlock, bond, or a combination of these mechanisms. The load-transfer mechanisms of anchors determine their performance characteristics.

All anchors can be classified into two main categories: cast-in-place, and post-installed. They may be further classified according to their principal load-transfer mechanisms.

### 2.2.1 Cast-In-Place Anchors

As the name implies, cast-in-place anchors are suspended in the formwork and concrete is cast around the anchor. Headed bolts, headed studs, "J" bolts, "L" bolts, threaded rods, and reinforcing bars are used as cast-in-place anchors. Load is transferred through bearing on the concrete by the head, hook, or deformation CEB 206 & 207 (1991). Some bond may also exist between the anchor shank and surrounding concrete. Figure 2.1 shows typical cast-in-place-anchors.

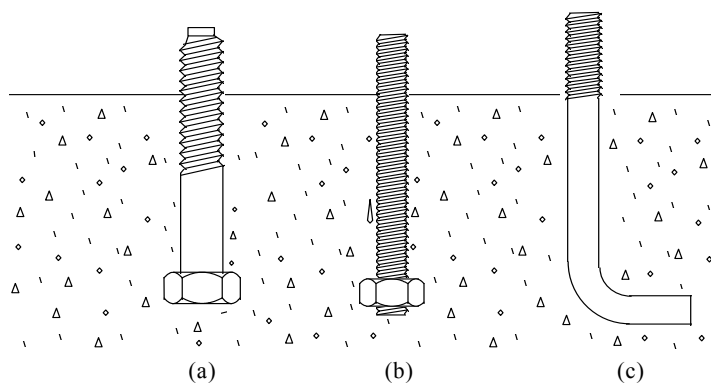

Figure 2.1 Typical Cast-In-Place Anchors

### 2.2.2 Post-Installed Anchors

Post-installed anchors are placed in hardened concrete. They are widely used in repair and strengthening work, as well as in new construction, due to advances in drilling technology, and to the flexibility of installation that they offer. Based on their installation procedures, post-installed anchors are further classified into four groups: self-drilling, bonded, expansion, and undercut.

Self-drilling anchors, also known as concrete screw anchors, are inserted into the structural member using a drill. Bonded anchors are inserted into holes larger than the diameter of the bolt and rely on bond between the bolt and an adhesive, and between the adhesive and the concrete, to transfer the load. Bonding agents include epoxies, vinylesters, polyesters, and cementitious grout.

a) Expansion Anchors

Expansion anchors are placed in a pre-drilled hole and rely on the expansion of a cone or wedge to transfer force between the anchor and the concrete. An expansion anchor consists of an anchor shank with a conical wedge and expansion element at the bottom end (Figure 2.2). The spreading element is expanded by the conical wedge during installation and throughout the life of the anchor. The spreading element is forced against the concrete wall of the hole as the wedge is pulled by tension on the anchor shank. The external load is transferred by the frictional resistance from the conical wedge to the spreading element, and from the spreading element to the surrounding concrete.

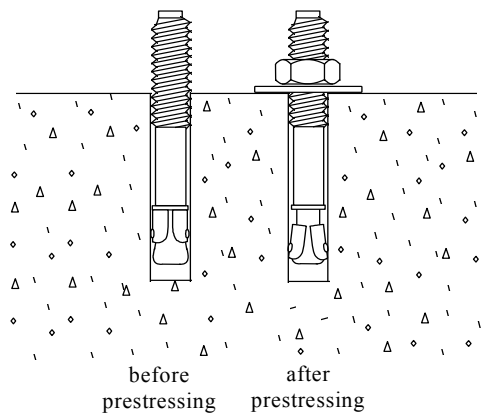

Figure 2.2 Expansion Anchors  
(before and after expansion)

Depending on the relative diameters of the bolt and the drilled hole, expansion anchors are classified as either bolt-type or sleeve-type anchors. For a bolt-type anchor, the nominal diameter of the drilled hole equals that of the anchor bolt. For a sleeve-type anchor, the nominal diameter of hole equals that of the sleeve encasing the bolt. A wedge anchor is the most common bolt-type anchor.

b) Undercut Anchors

Undercut anchors require a bell-shaped cut at the bottom of the predrilled hole. The cone of the anchor expands into the bell-shaped hole, and relies on bearing against the concrete to transfer load.

Different undercut geometries are used for various undercut anchor systems. Figure 2.3 shows the two different geometries of undercut anchors. It can be seen from this figure that Anchor UC2 has a much smaller bearing area on the surrounding concrete than Anchor UC1.

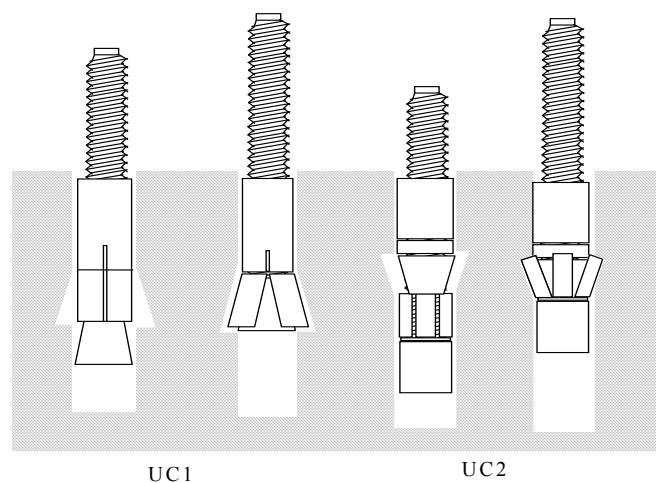

Figure 2.3 Undercut Anchors

### c) Grouted Anchors

A grouted anchor may be a headed bolt or a threaded rod with a nut at the embedded end, placed in a drilled hole filled with a pre-mixed grout or a Portland cement-sand grout (Figure 2.4). This type of anchor transfers load to the surrounding concrete primarily by friction at the interface between the grout and the concrete. The hole can be keyed or belled to increase the friction, or a deformed bar can be used instead of a threaded bolt.

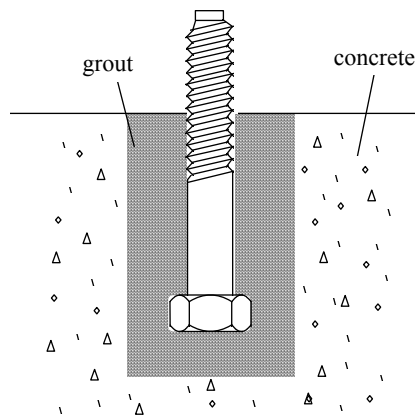

Figure 2.4 Grouted Anchor

#### 2.2.3. Definition of Embedment Depth

Anchors are commonly identified by a nominal embedment depth, used primarily to indicate the required hole depth. For most of the anchors studied here, that nominal embedment depth was the length of the anchor (sleeve, most undercut). For CIP anchors, it is the depth to the bearing surface. Nominal embedment depths are defined in Figure 2.5a.

The effective embedment depth of an anchor is the distance between the concrete surface and the bearing portion of the anchor head. For most anchors studied here, the effective and nominal embedment depths were equal. An exception is some expansion anchors, whose contact point (a dimple on the clip) is considerably above the end of the anchor. Effective embedment depths are defined as shown in Figure 2.5b.

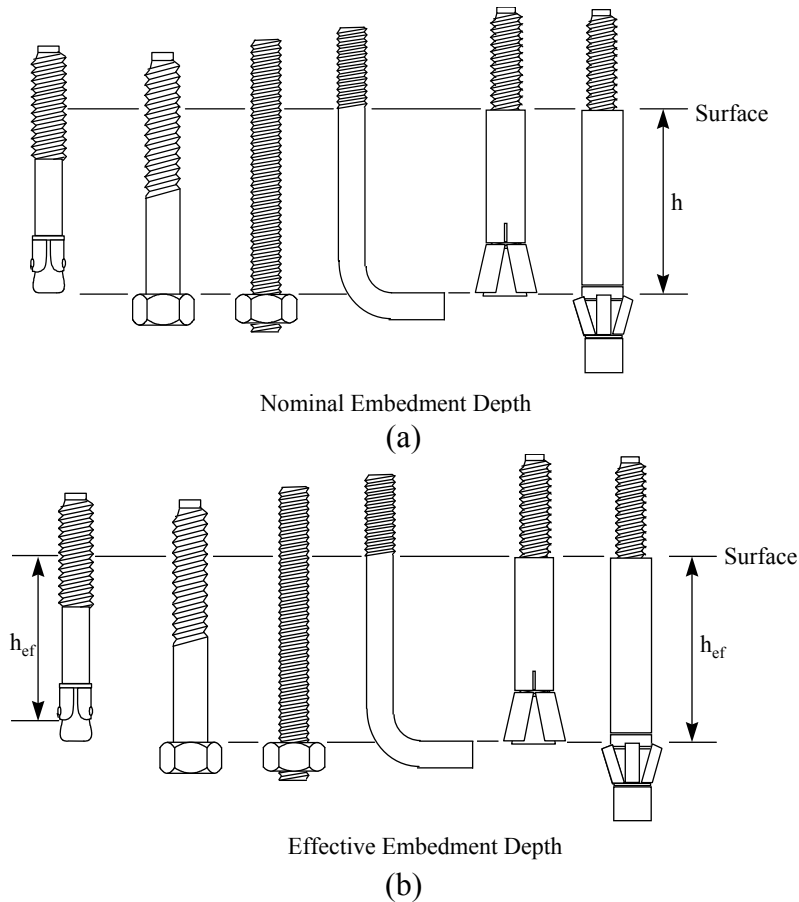

Figure 2.5 Demonstration of Anchor Embedment Depths

## 2.3 BEHAVIOR OF SINGLE-ANCHOR CONNECTIONS TO CONCRETE UNDER SHEAR LOADING

The anchor in plain concrete loaded in shear exhibits various failure modes, depending on the shear strength of the steel, the strength of surrounding concrete, the edge distance and the presence of adjacent anchors. These various shear failure modes and their corresponding capacities are discussed below.

### 2.3.1 Failure Modes and Failure Loads in Shear

#### a) Anchor steel failure in shear

Steel failure in shear occurs with bending, eventually leading to yield and rupture of the anchor shank. Due to the high local pressure in front of the anchor, a shell-shaped concrete spall may occur at the surface of the concrete before maximum load is obtained (Figure 2.6). This increases the deformation at failure of the anchor.

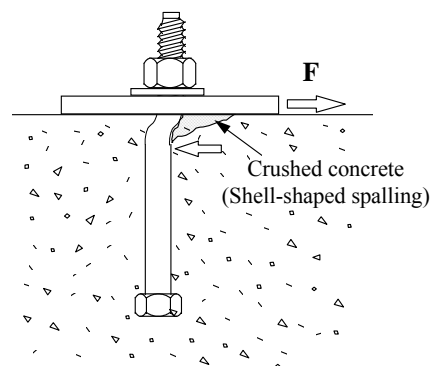

Figure 2.6 An Anchor Loaded in Shear



The shear capacity is a function of steel strength and cross-sectional area. It can be predicted by Equation (2-1):

$$V_n = \alpha T_{nt} = \alpha A_s F_{ut} \quad (2.1)$$

where:

$V_n$  = shear strength of the anchor shank;

$A_s$  = cross-sectional area of the anchor;

$F_{ut}$  = minimum specified tensile strength of the anchor steel;

$\alpha$  = reduction factor.

If the threads are in the shear plane, the effective stress area of Equation (2-2) should be used.

$$A_s = 0.7854 \left[ D - \frac{0.9743}{n} \right]^2 \quad (2.2)$$

In ACI 349 Appendix B (1990), "Requirements for Nuclear Safety Related Structures, Steel Embedments", shear transfer is ascribed to shear friction. It is assumed that bolt shear is transmitted from the bolt to the concrete through bearing of the bolt at the concrete surface, forming a concrete wedge. The wedge is assumed to be pushed upward against the steel plate by the bolt, which produces a clamping force between the wedge and the baseplate, leading to a friction. This friction is assumed to increase in proportion to the clamping force and therefore to the shear on the anchor, as long as the anchor remains elastic. In

ACI 349, the coefficient  $\alpha$  in Equation (2-1) is treated as a friction coefficient, whose value varies with different plate position on the concrete surface (inset, surface, or grout pad). Even though the shear-friction mechanism is not consistent with tests in which the loading plate rotates away from the concrete surface, capacity can be correctly predicted by shear friction theory. Alternately, the coefficient  $\alpha$  can be regarded as the ratio between the ultimate strength of the anchor in shear and in tension. The reduction factor  $\alpha$  varies with the type of anchor. Cook (1989) excluded the effect of friction between the steel baseplate and the concrete surface, and determined that for an anchor whose sleeve is flush with the surface of the concrete, a value of 0.6 can be used. This is about  $1/\sqrt{3}$ , the theoretical ratio of shear to tensile yield according to the von Mises model. For anchors without sleeves, the average value was determined to be 0.5.

b) Concrete cone breakout in shear

Concrete breakout usually occurs when the anchor is located close to the free edge of a member and is loaded in shear towards the edge. The angle  $\alpha$  (Figure 2.7) varies from small angles with small edge distances to large angles with large edge distances.

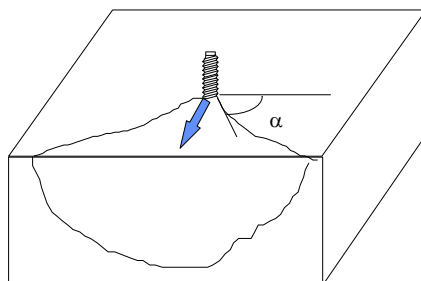

*Figure 2. 7 Lateral Concrete Cone Failure*

Many procedures have been proposed to predict the concrete shear capacity. Some of them were compared against test results (Klingner and Mendonca 1982b, CEB 1991, Fuchs et al. 1995). The most widely used are the 45-Degree Cone Method and the CC Method. In the following, these two methods are described.

### 45-Degree Cone Method

Using an analogous assumption as for tension anchors, that a tensile stress of  $4\sqrt{f'_c}$  acts on a 45-degree concrete half-cone, leads to Equation (2-3):

$$V_{no} = 2\pi\sqrt{f'_c}c_1^2 \quad \text{lb} \quad (2.3a)$$

$$V_{no} = 0.48\sqrt{f'_c}c_1^2 \quad \text{N} \quad (2.3b)$$

where:

$c_1$  = edge distance in loading direction.

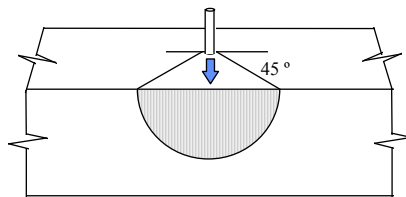

*Figure 2. 8 Idealized Shape of Shear Breakout Cone of a Single Anchor*

If the depth of the concrete member is smaller than the edge distance, or the spacing of anchors is smaller than  $2c_1$ , or the width of the concrete member is smaller than  $2c_1$ , or any combination of these, the capacity is modified as follows:

$$V_n = \frac{A_v}{A_{v0}} V_{no} \quad (2-4)$$

where:

$A_v$  = actual projected area of semi-cone on the side of concrete member;

$A_{v0}$  = projected area of one fastener in thick member without influence of spacing, and member width, idealizing the shape of projected fracture cone as a half-cone with a diameter of  $c_1$ , ( $A_{v0} = (\pi/2) c_1^2$ ).

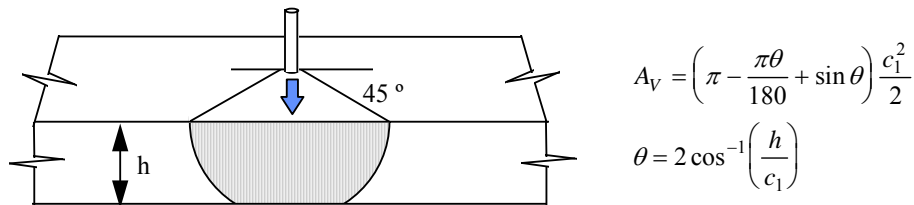

Figure 2. 9 Projected Areas for Shear Anchors According to 45-Degree Cone Method

### Concrete Capacity Method (CC Method)

Based on regression analyses of a large number of tests with headed, expansion, and adhesive anchors, the following formula was proposed for the calculation of shear breakout capacity (Fuchs 1995):

$$V_{no} = 13 (d_o f_c)^{0.5} \left( \frac{\ell}{d_o} \right)^{0.2} c_1^{1.5} \quad \text{lb} \quad (2-5a)$$

$$V_{no} = 1.0 (d_o f_{cc})^{0.5} \left( \frac{\ell}{d_o} \right)^{0.2} c_1^{1.5} \quad \text{N} \quad (2-5b)$$

where:

$d_o$  = the outside diameter of the anchor (inch in US units, mm in SI units);

$\ell$  = activated load-bearing length of fasteners,  $\leq 8d_o$ ;

=  $h_{ef}$ , for fasteners with a constant overall stiffness;

=  $2d_o$  for torque-controlled expansion anchors with spacing sleeve separated from the expansion sleeve;

$f_c$  = specified compressive strength of concrete; and

$c_1$  = edge distance in the direction of load.

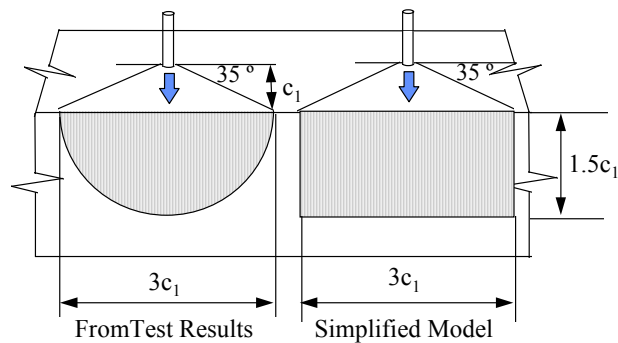

*Figure 2.10 Idealized Design Model for a Single Anchor Under Shear in CC Method*

The above formula is for the mean rather than 5% fractile concrete breakout capacity in uncracked concrete. It is valid for a member with a

thickness of at least  $1.4h_{ef}$ . For anchors in a thin structural member or affected by the width of the member, by adjacent anchors, or both, a reduction must be made based on the idealized model of a half-pyramid measuring  $1.5c_1$  by  $3c_1$ .

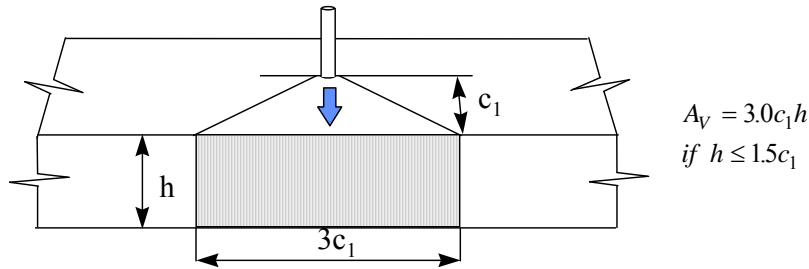

Figure 2. 11 Projected Areas for Shear Anchors in Thin Members According to CC Method

$$V_n = \frac{A_v}{A_{vo}} \psi_4 \psi_5 \psi_6 V_{no} \quad (2-6)$$

where:

$A_v$  = actual projected area at the side of concrete member;

$A_{vo}$  = projected area of one fastener in thick member without influence of spacing and member width, idealizing the shape of the projected fracture cone as a half-pyramid with side length of  $1.5c_1$  and  $3c_1$ ;

$\psi_4$  = modification factor for shear strength to account for fastener groups that are loaded eccentrically;

$\psi_5$  = modification factor to consider the disturbance of symmetric stress distribution caused by a corner;

= 1, if  $c_2 \geq 1.5 c_1$

$$= 0.7 + 0.3 \frac{c_2}{1.5c_1}, \text{ if } c_2 \leq 1.5 c_1;$$

where;

$c_1$  = edge distance in loading direction;

= max. ( $c_{2,\max}/1.5$ ,  $h/1.5$ ) for anchors in a thin and narrow member

with  $c_{2,\max} < 1.5c_1$  and  $h < 1.5c_1$ ;

where;

$h$  = thickness of concrete member;

$c_2$  = edge distance perpendicular to loading direction.

$\psi_6$  = modification factor for shear strength to account for absence or control of cracking.

In analyzing all single anchor data, it was assumed that  $\psi_4$  was equal to 1.0 (no eccentricity for single anchors), and that  $\psi_6$  was equal to 0.714 for all cracked cases, and to 1.0 for all uncracked cases.

c) Anchor pryout

Anchor pryout is characterized by crushing of concrete in front of the anchor, combined with breakout of the concrete behind the anchor, leading to anchor pullout, as shown in Figure 2.12. It generally happens to anchors with small embedment depths. Prediction formulas for this kind of failure are not currently available.

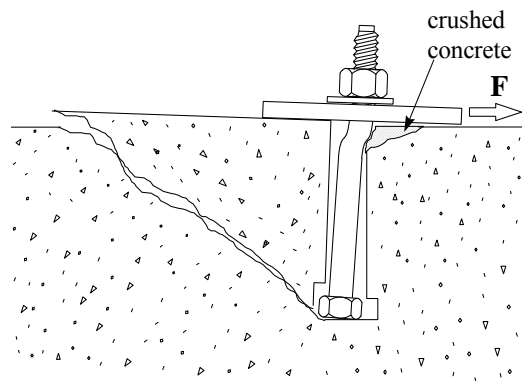

Figure 2. 12 Pryout Cone Failure

### 2.3.2 Load-Displacement Curves of Anchors in Shear

The shear load-shearing displacement history of an anchor failing by steel rupture, comprises the steel shear deformation, and the steel flexural deformation as a result of concrete spalling in front of the anchor. In case of concrete breakout failure, the total deformation consists mainly of concrete deformation, with little steel deformation, and shell-shaped concrete spalling is usually not observed, due



to the smaller failure load. Figure 2.13 shows typical load-displacement curves of anchors in shear, associated with various failure modes.

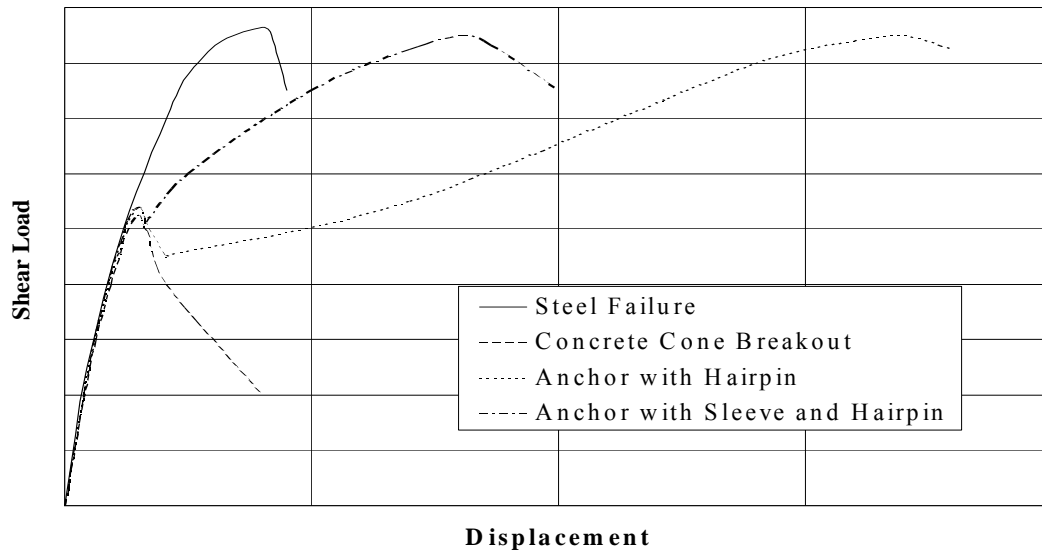

Figure 2. 13 Typical Load-Displacement Curves of Anchors in Shear

## 2.4 CURRENT DESIGN GUIDELINES

ACI Building Code has included specific provisions for fastening to concrete for the first time. This reflects the increased demand from code users for comprehensive coverage of this important application, and the considerable research and design developments stimulated by several ACI Committees. Below is a general summary of basic guidelines in documents such as ACI 318, ACI 349, USI A-46 SQUG Report, and the ACI 355 State of the Art Report.

#### **2.4.1 ACI 318 (Anchorage Proposal, Appendix F of this thesis)**

The draft proposal for ACI 318 Chapter 23 provides design requirements for structural fasteners which transmit structural loads from attachments into concrete members by means of tension, shear or a combination of tension and shear. The levels of safety defined by the combinations of load factors and  $\phi$ -factors are appropriate for structural applications. The  $\phi$ -factors for concrete are dependent on whether the fastener is designed to be ductile or non-ductile.

In regions of moderate and high seismic risk, fasteners shall be designed for ductile shear failure of steel with initial concrete failure modes precluded and the design strength should be reduced by 0.75.

According to the ACI 318 draft the basic design concrete capacities should be based on 5 percent fractile of the basic individual fastener capacity with modifications made for the number of anchors, the effects of close spacing of fasteners, proximity to edges, depth of the concrete member, eccentric loading of fastener groups, and presence or absence of cracking. Default formulas for predicting concrete breakout capacity are based on the CC Method.

#### **2.4.2 ACI 349 (Chapter 23 Draft, Appendix G of this thesis)**

The draft proposal for ACI 349 Chapter 23 provides design requirements for structural embedments used to transmit structural loads from attachments into concrete members by means of tension, shear, bearing or a combination thereof.

ACI 349 uses the term “embedments” to cover a broader scope than ACI 318. It includes embedded plates, shear lugs, inserts and reinforcement.

The ACI 349 draft also computes the basic design concrete breakout capacity based on 5 percent fractile of the basic individual fastener capacity with modifications made for the number of anchors, the effects of close spacing of fasteners, proximity to edges, depth of the concrete member, eccentric loading of fastener groups, and presence or absence of cracking. Default formulas for predicting breakout capacity are based on the CC Method. The  $\phi$ -factors for concrete depends on whether the embedment is designed to be ductile or non-ductile. For ductile fastener design the  $\phi$ -factors are set based on a combination of engineering judgement and statistical evaluations. For non-ductile design approach the  $\phi$ -factor for concrete breakout is reduced by 0.6 to have the same probabilities of failure for both non-ductile and ductile design approaches.

The additional requirements in the ACI 318 draft for seismic loads are not added to the ACI 349 draft, since the requirements of the draft ACI 349 Chapter 23 have been specified assuming that seismic loads are significant. Seismic loads are determined by elastic analyses and ductile fastener design is encouraged. In addition, the  $\phi$ -factors for non-ductile fasteners are lowered compared to those of the ACI 318 draft.

Embedment design shall be controlled by the strength of embedment steel. Steel strength  $V_s$  controls when concrete breakout shear strength  $V_{cb}$  exceeds 65 percent of the specified ultimate tensile strength of the embedment steel.

The ACI 349 draft has explicit requirements intended to ensure capacity in case of overload. Materials for ductile embedments should have a minimum elongation of 14% in 2 inches. In addition if there is a reduced section in load path then the ultimate strength of the reduced section shall be greater than the yield strength of unreduced section. This is intended to ensure that the unreduced section yields prior to failure of the reduced section, providing sufficient inelastic deformation to allow redistribution of anchor tension and shear loads.

The ACI 349 draft excludes use of undeformed hooked anchors since their behavior in cracked concrete is not well defined. Furthermore, ACI 349 draft requires that all post-installed fasteners be qualified for use in cracked concrete.

### **2.4.3 USI A-46, SQUG REPORT**

The "SQUG Report"<sup>1</sup> was prepared by the Seismic Qualification Utility Group (SQUG), a consortium of members of the Electric Power Research Institute (EPRI) and the US NRC. Access to the document is restricted to

---

<sup>1</sup> "Seismic Verification of Nuclear Plant Equipment Anchorage (Revision 1), Volume 1: Development of Anchorage Guidelines," (*Report No. EPRI NP-5228-SL*), URS / John A. Blume & Associates, San Francisco, California, June 1991.

participants in that group. As an NRC contractor on the project described in this thesis, Prof. Richard E. Klingner (UT Austin) obtained access to this document at the offices of the US Nuclear Regulatory Commission in Gaithersburg, Maryland.

The report's purpose was to propose a mechanism by which licensees (nuclear plant operators under the jurisdiction of the NRC) could address the NRC's USI A-46 ("Unresolved Safety Issue A-46"), involving the seismic safety of anchorages for mounted equipment.

The US NRC has ruled<sup>2</sup> that USI A-46 licensees can use the USI A-46 (GIP) methodology for verifying the seismic adequacy of anchorages for mounted equipment. Previous specific arrangements with NRC are not superseded by this.

In this section, the methodology of the SQUG Report is summarized and evaluated. The evaluation represents the opinions of Prof. Klingner and the author of this thesis.

#### ***Verbatim Abstract of SQUG Report***

The material in this sub-section is taken verbatim from the abstract at the front of the SQUG Report.

---

<sup>2</sup> SUPPLEMENT NO. 1 TO GENERIC LETTER (GL) 87-02 THAT TRANSMITS SUPPLEMENTAL SAFETY EVALUATION REPORT NO. 2 (SSER No. 2) ON SQUG GENERIC IMPLEMENTATION PROCEDURE, REVISION 2, AS CORRECTED ON FEBRUARY 14 1992 (GIP-2).

*The anchorage guidelines provide utility engineers with comprehensive procedures and criteria for evaluating the seismic adequacy of a wide variety of equipment anchorage types, including expansion anchors, welds, cast-in-place (CIP) bolts, and other types of fasteners. These guidelines are the basis and principal reference for the anchorage evaluation procedures in the Seismic Qualification Utility Group (SQUG) Generic Implementation Procedure for resolution of Unresolved Safety Issue (USI) A-46.*

***Background:*** *Seismic evaluations of older nuclear power plants have indicated that equipment anchorage is one of the most important engineering features by which plant seismic capacity can be readily and practically improved. Equipment anchorage has become the focal point of walkdown procedures developed by SQUG and EPRI for resolution of both USI A-46 and seismic aspects of NRC Severe Accident Policy issues. Because of the variety of available anchorage devices, a generic assessment procedure is needed for resolution of each of these issues.*

***Objective:*** *To develop guidelines for the seismic evaluation of equipment anchorage in existing nuclear power plants.*

**Approach:** *For the original report the research team collected test data on shear and pullout capacities of expansion anchors and developed allowable loads with appropriate safety factors. For CIP bolts and welds, they adopted existing industry guidelines. The team developed capacity reduction factors for various installation parameters such as close spacing and edge distance. They also formulated two alternative procedures for inspecting and evaluating bolts in a plant, including checklists and screening tables for different types of components. In the revision, the same team expanded the database to include a wider variety of bolt types, and used recent test results to update and improve the capacity reduction factors. They also developed a computer program for rapid in-plant evaluation of anchor systems, and added consideration of phenomena such as prying action, preload relaxation, and overall anchorage system stiffness.*

**Results:** *Report NP-5228-M, revision 1, summarizes the guidelines. Report NP-5228-SL, revision 1, consists of four volumes. Volume 1 contains the guidelines. Volume 2 provides a workbook for field evaluation. Volume 3 offers a user's manual for the computer program, EPRI / Blume Anchorage Computer Program (EBAC), used for comparison of demand and capacity. Volume 4 describes a major change to the guidelines, the addition of comprehensive calculation and inspection procedures for tank and heat exchanger anchorage. The anchorage criteria and procedures in these four volumes have been incorporated into the SQUG Generic Implementation Procedure for resolution of USI A-46. The*

*guidelines have been successfully used in their original form in seismic evaluations of the Catawba, Maine Yankee, and E. I. Hatch nuclear power plants.*

***EPRI Perspective:*** *It has long been a widely held opinion in the technical community that equipment anchorage should be the focus of any plant evaluation to assess seismic adequacy or improve plant seismic safety. This has been reflected to date in trial evaluations showing that (1) most "outlier" conditions are anchorage-related and relatively easy and inexpensive to resolve and (2) upon resolution, the anchorage capacity can be substantially in excess of design basis earthquake loads. This report, along with reports NP-5223, revision 1, and NP-7147, which provide generic equipment ruggedness spectra (GERS), and report NP-7148, which describes procedures to assess electrical relay seismic functionality, complements the seismic experience data collected by SQUG and EPRI to form the basis for cost-effective resolution of USI A-46.*

### ***Summary of Essential Aspects of SQUG Report***

The essential aspects of the SQUG Report are a series of proposed actions for determining the capacity of existing connections:

First, in any given connection, the shear and tension on each fastener should be calculated (presumably using elastic principles), and the most highly stressed fastener should be identified.



Next, fastener loads should be determined for seismic input consisting of 1g in two horizontal directions and 2/3 g in the vertical direction. The loads on the most highly stressed fastener should be compared with allowable loads (see below), to determine a scale factor that would make the maximum applied fastener load exactly equal to the allowable value.

The key step in the SQUG Report is the proposed procedure for determining allowable loads for individual fasteners. For expansion anchors in tension, the proposed procedure involved the following steps:

- 1) A data base was developed of results for tension and shear tests on different types of expansion anchors. About 2400 tension tests were available, and about 1300 shear tests. About two-thirds of the results were pre-existing; the rest were produced for purposes of the report.
- 2) That data base was modified to retain only those tests in which the embedment depth was less than or equal to the manufacturer's minimum required value. Some tests with intentional defects were retained. The remaining data base had about 750 tension tests and about 400 shear tests, primarily involving 4 manufactured brands of expansion anchor.
- 3) All those anchors were lumped together. For  $f'_c \geq 3500$  psi, results were insensitive to concrete strength, suggesting that most anchors failed by

pullout and slip. Regression curves were prepared for capacity as a function of the specified concrete strength. Those curves had a significant scatter ( $COV \sim 40\%$ ). The curves had  $(P_{test}/P_{mean})$ , or  $(V_{test}/V_{mean})$  as appropriate, on the vertical axis, and the specified concrete strength  $f'_c$  on the horizontal axis. Empirical reduction factors were proposed to address the effects of concrete strengths less than 3500 psi.

- 4) For each anchor diameter, the mean anchor capacity for all anchors was then used to establish an allowable capacity. For uncracked concrete, a factor of safety of 2.0 was adopted. This value was also compared with the results of tests conducted at the University of Stuttgart.
- 5) The appropriateness of this factor of safety was then examined. For each anchor type and diameter, the researchers calculated the percentages of individual anchor with pullout capacities less than one-half the mean pullout capacity for the entire group, at that diameter. For some anchor types, that percentage was thought to be unacceptably high. To address this problem, and also the effects of dynamic loading and cracked concrete, the factor of safety was increased to 3.0. That is, the allowable load for any particular anchor was taken as one-third of the mean failure load for all anchors of that diameter.

- 6) Anchors for which test data were not readily available were included in the data base on the basis of a "capacity ratio," consisting of the ratio of average anchor capacity (all diameters, as reported by the manufacturer) to the average anchor capacity of the anchors already in the data base.
- 7) Using data from Rehm, Eligehausen and Mallée (1988), American Concrete Institute Special Publication 103 (Eligehausen and Mallée, 1987), and work by the Tennessee Valley Authority on expansion anchor performance in cracked concrete (Cannon, 1980), it was assumed that for any crack widths up to 10 mills (0.25 mm), the reduction in capacity due to cracks would be covered by the factor of safety of 3.0. Visual inspection was suggested to determine if cracks are actually present.
- 8) Based on several reports from Bechtel, ASCE, PG&E, and Teledyne, researchers concluded that the ultimate capacity of anchors under alternating dynamic load would not be much different from the capacity under static load.
- 9) Researchers concluded that because loss of preload doesn't affect ultimate load, it would not be considered further in the SQUG Report.

- 10) Based on industry guidelines, it was assumed that anchors would experience no reduction in capacity for spacing exceeding 10 bolt diameters, nor for edge distances exceeding about 8 to 10 diameters.

The following step was proposed for shear anchors:

- 11) For near-edge anchors, it was recommended to use a reduction factor proportional to edge distance raised to the power 1.5.

The following step was proposed for evaluating shear-tension interaction:

- 12) Interaction of shear and tensile capacities should be handled conventionally, using either a quadratic or a bilinear interaction relationship.

The following treatment was proposed for J-bolts:

- 13) The researchers developed no new data. They recommended that J-bolts be treated like hooked deformed reinforcing bars in concrete.

### ***Evaluation of Essential Aspects of SQUG Report***

In this section, the essential aspects of the SQUG Report are evaluated, based on the research background presented earlier in this thesis.

The proposed elastic procedure for calculating the shear and tension on each fastener is generally conservative for the critical (most heavily loaded) fastener. However, it can be affected in an unconservative manner by differences in anchor preload or hole tolerance (Cook 1989, Zhang 1997).

The SQUG Report's proposed procedures for determining allowable loads for individual fasteners are now evaluated, numbering the steps as in the previous section:

- 1,2) The data base of expansion anchors has many tests. However, the work of Rodriguez (1995) and Hallowell (1996) implies that the performance of expansion anchors varies markedly from brand to brand. Therefore, conclusions drawn on the basis of some expansion anchors will probably not be valid for other expansion anchors. This is particularly true for capacities as governed by pullout failure.
- 3) The large coefficient of variation in the SQUG pullout capacities implies wide variations among brands of expansion anchors.
- 4,5) The use of an arbitrary factor of safety (2.0 or 3.0) cannot be expected to give a predictable, reliable, or satisfactory factor of safety against failure. This could be done only by statistical studies of the probability of failure

- 6) Because manufacturers' testing procedures were often not controlled, pullout capacities based on manufacturers' test data are not uniformly reliable. As a result, the proposed procedure for estimating the allowable capacity of otherwise untested anchors based on manufacturers' test data, does not seem reliable.
- 7) As noted above, reductions in capacity due to cracking cannot be expected to be covered by arbitrary factors of safety, for anchors whose performance in cracked concrete has not been verified. Visual inspection cannot be depended on to detect cracks that would form in a critical loading event.
- 8) Testing at The University of Texas at Austin (Zhang 1997) has shown that expansion anchors that pull out under static loads will also pull out under reversed cyclic loading representative of the seismic response of mounted

equipment. After several cycles, the amount of pullout can be enough to render the connection essentially non-functional. Under these circumstances, it is optimistic to expect that connection capacity will be unchanged under dynamic loading.

- 9) While it is true that preload doesn't affect ultimate capacity under static loading, loss of preload can lead to pullout, which seriously degrades the seismic performance of connections (Zhang 1997). The SQUG Report's conclusions in this regard ("no effect") are too optimistic.
- 10) The SQUG Report's guidelines for reductions in tensile capacity with respect to spacing and edge distance are not supported by the research of the past 15 years related to the CC Method (Fuchs 1995).
- 11) For near-edge shear anchors, it is reasonable to use a reduction factor proportional to edge distance raised to the power 1.5.
- 12) For interaction of shear and tensile capacities, it is reasonable to use either a quadratic or a bilinear interaction relationship.
- 13) It does not seem reasonable to treat J-bolts like hooked deformed reinforcing bars in concrete. The former are much smoother than the latter.

#### **2.4.4 ACI 355 STATE OF THE ART REPORT**

At the time the original Request for Proposal was issued by the US Nuclear Regulatory Commission (mid-1996), ACI Committee 355 was planning to update its state-of-the-art document summarizing the design recommendations of ACI Committees 318 and 349, and offering its own recommendations. At about the same time, the rate of development of draft design provisions in Committees 318 and 349 increased significantly.

Many volunteer members of Committee 355 who would have been involved in updating the 355 document were also involved in work in Committees 318 and 349, the leadership of Committee 355 decided that it would be more effective for those members to devote their time to work in Committees 318 and 349, which were actually developing design provisions.

As a result, the Committee 355 state-of-the-art document has not been updated, and that document is not discussed further here.



## **CHAPTER THREE**

### **EVALUATION OF SHEAR BREAKOUT DATA**

#### **3.1 INTRODUCTION**

A major objective of this thesis is the compilation of a reliable shear database like that accepted for tensile anchors. For this purpose a literature review for shear test results has been conducted. Tests are from US and Europe.

The shear database is composed of four Categories:

- a) Single and double anchors, in uncracked concrete, under static shear loading;
- b) Single anchors, in cracked concrete, under static shear loading;
- c) Single anchors, in uncracked concrete, under dynamic shear loading;
- d) Single anchors, in cracked concrete, under dynamic shear loading.

All data in these categories are for concrete cone failure.

Test data for shear breakout from a wide range of tests are compared with the predictions of the CC Method (Fuchs 1995) and the 45-Degree Cone Method .

In addition the performance of a formula obtained by multivariate regression analysis is evaluated using the data for Anchor Category (a) (single and double anchors in uncracked concrete under static shear loading). This approach can be considered as a variation of the CC Method.

### **3.2 CRITERIA IN COMPILATION AND EVALUATION OF DATABASE**

The concrete shear breakout capacities are computed using the CC method and 45-Degree Cone Method. The details about the form of these formulas and criteria in selecting test data are summarized below.

- a) Only tests with concrete breakout failure were included.
- b) Only tests on cast-in-place, expansion and undercut anchors were included.
- c) The tests are from US and Europe. Some static shear tests in uncracked concrete from Germany are not included, because the mean ( $V_{obs}/V_{pred}$ ) values were 20% lower than the rest of the data in this category (0.859 vs. 1.075). In addition the coefficient of variation was around 0.4 which is much higher than the rest of the data. The reason for this much difference could be lack of details about the German data such as the thickness of concrete members. It is assumed that there is no reduction in capacity due to thickness of concrete slabs for the calculation of ( $V_{obs}/V_{pred}$ ) for these tests.

- d) The tests were sorted according to two main criteria: type of loading (static or dynamic); and condition of concrete before the test (cracked or uncracked). As a result, the effect of load type and concrete condition on concrete capacity could be investigated.
- e) Since instrumentation for dynamic load tests is more complex than for static load tests, only limited data could be found for dynamic load cases.
- f) Most of the tests on multiple-anchor connections could not be included, because load-carrying mechanism and failure sequence are complex. In multiple-anchor connections, some anchors experience steel failure under shear and tension, while others fail by concrete breakout. Since it is normally not possible to measure the tensile and shear failure loads taken by each anchor, nor the friction between baseplate and concrete, it is difficult to decide how anchors share axial and shear load.
- g) The confining effect of baseplate and presence of reinforcement affect the type of failure and concrete breakout load. The compression on concrete from the baseplate around some anchors usually increases the concrete breakout load. In addition, reinforcement may also confine the concrete after cracking. Since these points are not fully understood, tests with reinforcement in concrete were not included.
- h) Out-of-plane eccentric loading is another factor that affects load-carrying mechanism and type of failure. The eccentricity changes the

type and magnitude of the load taken by each anchor, and the friction between baseplate and concrete. Because these points are still under investigation, tests with out-of-plane eccentricity were not included.

- i) Estimates of the mean basic shear strength for concrete breakout  $V_{pred}$  in uncracked concrete were based on Equations (2-3b) and (2-4) for the 45-Degree Cone Method, and on Equations (2-5b) and (2-6) for the CC Method. Equation (2-5b) was modified using a correction factor of 0.714 for the case of cracked concrete.

### **3.3 PROPOSED CAPACITIES FOR DESIGN OF SHEAR ANCHORS**

In this thesis all basic shear strength for concrete breakout are computed based on the CC Method normalized to correspond to mean observed values (Equation 2.5b). SI units are used in all calculations. Table 3.1 gives the normalization constant “k” and strength reduction factor  $\phi$  for concrete breakout for normalizations based on the mean and on the lower 5% fractile. The nominal capacities used in the draft for ACI 349 and the draft for ACI 318 are the 5 percent fractiles (90 percent confidence that there is a 95 percent probability that the actual strength will exceed nominal strength).

It is seen from Table 3.1 that if the breakout formula is calibrated based on the 5% fractile rather than the mean, the “k” value decreases. To maintain the same safety level, the  $\phi$ -factor must increase. Since the 5% percent fractile is taken as corresponding to 75 percent of the mean, then the

Table 3.1 Normalization Constant “k” and corresponding  $\phi$ -factor for Different Design Approaches

Value	ACI 349 (Mean)	ACI 349 Ductile Design (5% fractile)	ACI 349 Brittle Design (5% fractile)
Normalization Constant k for Uncracked Concrete	1.00	0.75	0.75
Strength Reduction Factor for Concrete Breakout	0.65	0.85	0.50
Design Capacity in Uncracked Concrete	0.65	0.64	0.38
Normalization Constant k for Cracked Concrete	0.70	0.70	0.70
Design Capacity in Cracked Concrete	0.46	0.45	0.27
Maximum Factored Design Load for Cracked Concrete	0.35	0.35	0.27

corresponding  $\phi$ -factor for the same probability of failure will be the original  $\phi$ -factor, divided by 0.75.

In other words, if “k” is based on the assumed 5% fractile, a reasonable strength reduction factor for concrete will be 0.87. This value is taken as 0.85, which is already familiar to users of the ACI Code for other diagonal tension failure mechanisms. For non-ductile design, the  $\phi$ -factor is further reduced by 0.6 to have about the same probabilities of failure as with ductile

design approach. For the draft ACI 349 ductile method of design, the maximum factored design load is obtained by taking the concrete breakout capacity, dividing by the estimated ratio of ( $f_{ut}/f_y=1.2$ ), and multiplying by the  $\phi$ -factor of 0.9 for steel. The maximum factored design load is calculated directly as the design capacity when the brittle method is used.

### **3.4 SHEAR BREAKOUT DATA FOR SINGLE AND DOUBLE ANCHORS IN UNCRACKED CONCRETE UNDER STATIC LOADING**

The data in this category come from Hallowell (1996) (5 tests), from Maxibolt (1992) (5 tests), from Klingner (1992) (85 tests), and from Hilti (1997) (154 tests). Twenty-seven of these tests are in lightweight concrete, and the rest, in normal-weight concrete. The Hallowell (1996) and Klingner (1992) tests are on cast-in-place anchors and the Hilti (1997) and Maxibolt (1992) tests are on expansion and undercut anchors respectively.

Figure 3.1 shows the variation of  $(V_{obs}/V_{pred})$  with edge distance  $c_1$ , based on the CC Method (Fuchs 1995). A linear regression is fitted to the data. In general,  $(V_{obs}/V_{pred})$  decreases as edge distance increases.

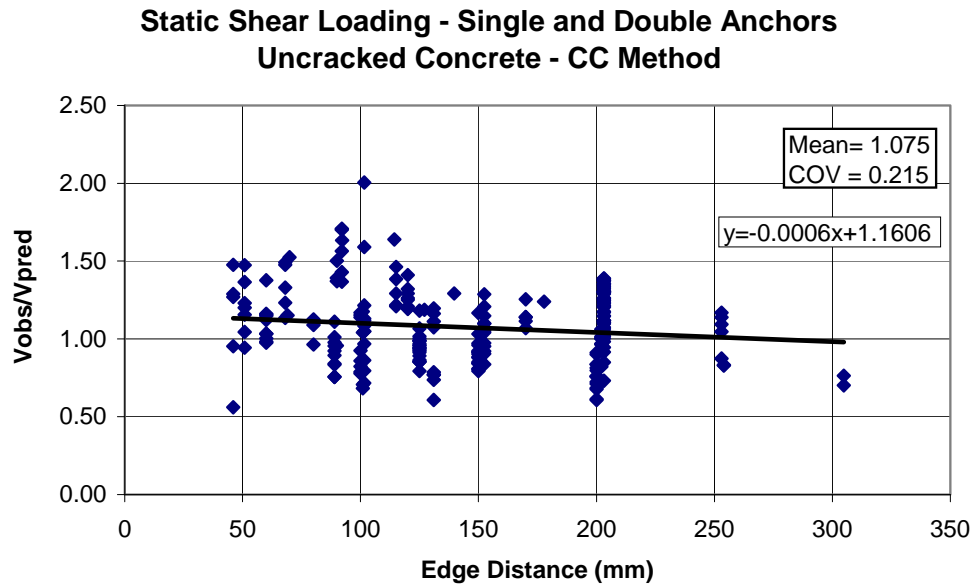

Figure 3.1 Ratios of Observed to Predicted Concrete Shear Breakout Capacities, CC Method (File: shear.xls, Sheet: s-1-u-s)

This behavior of the best-fit line indicates that the exponent applied to the edge distance  $c_1$  in the current equation is slightly high. The negative slope is mainly the result of low  $(V_{obs}/V_{pred})$  values for few tests with edge distances larger than 250 mm.

Figure 3.2 shows the variation of  $(V_{obs}/V_{pred})$  with edge distance  $c_1$ , based on the 45-Degree Cone Method. Mean values of Figure 3.1 and Figure 3.2 are almost the same, but the coefficient of variation is higher for the 45-Degree Cone

Method. The negative slope of the best-fit line is quite high, indicating an unconservative behavior for large edge distances, and conservative results for edge distances smaller than 150 mm. This inconsistent behavior is due to the fact

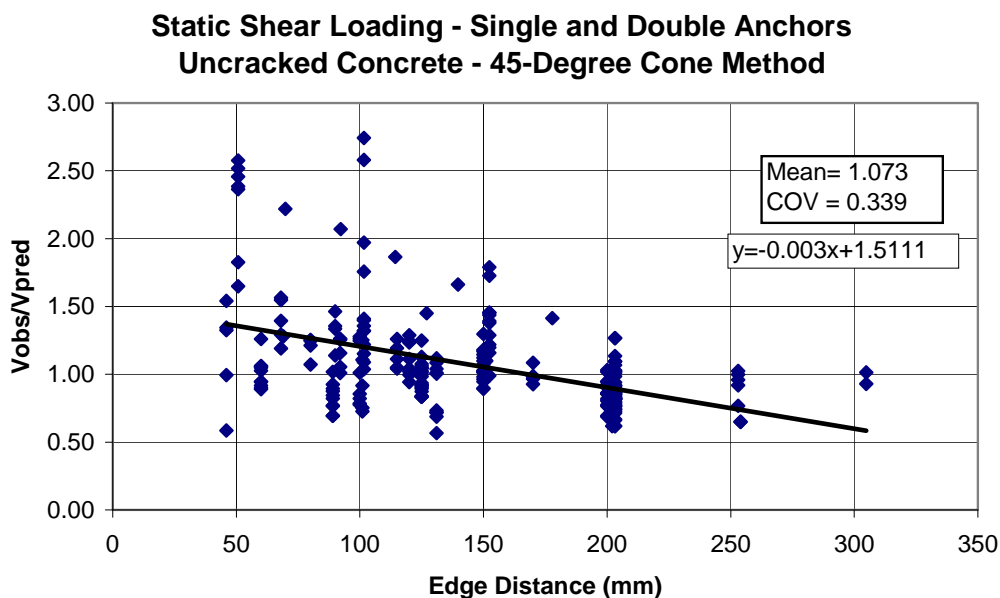

Figure 3.2 Ratios of Observed to Predicted Concrete Shear Breakout Capacities, 45-Degree Cone Method (File: shear.xls, Sheet: s-1-u-s)

that the 45-Degree Cone Method does not consider the size effect.

The outliers for which mean values are higher than 1.50 correspond to tests from Maxibolt (1992). That reference states that the tensile strength of concrete was higher than the value used in the CC Method and 45-Degree Cone Method equations. This can be the reason for high ( $V_{obs}/V_{pred}$ ) values. See Discussion No. 10 in Section 3.8 of this thesis.



### **3.5 SINGLE ANCHORS IN CRACKED CONCRETE UNDER STATIC SHEAR LOADING**

The data come from Hallowell (1996) (5 tests) and Klingner (1992) (7 tests), all on CIP anchors. Figure 3.3 shows the variation of ( $V_{obs}/V_{pred}$ ) with edge distance  $c_1$ , based on the CC Method (Fuchs 1995). The negative slope of the best-fit line is lower than that of the uncracked concrete case, and is close to zero. Since the desired result is an equation with a mean close to 1.0 and essentially zero systematic error (a horizontal best-fit line), the CC Method (Fuchs 1995) seems adequate to predict the breakout capacity of anchors in cracked concrete under static loading.

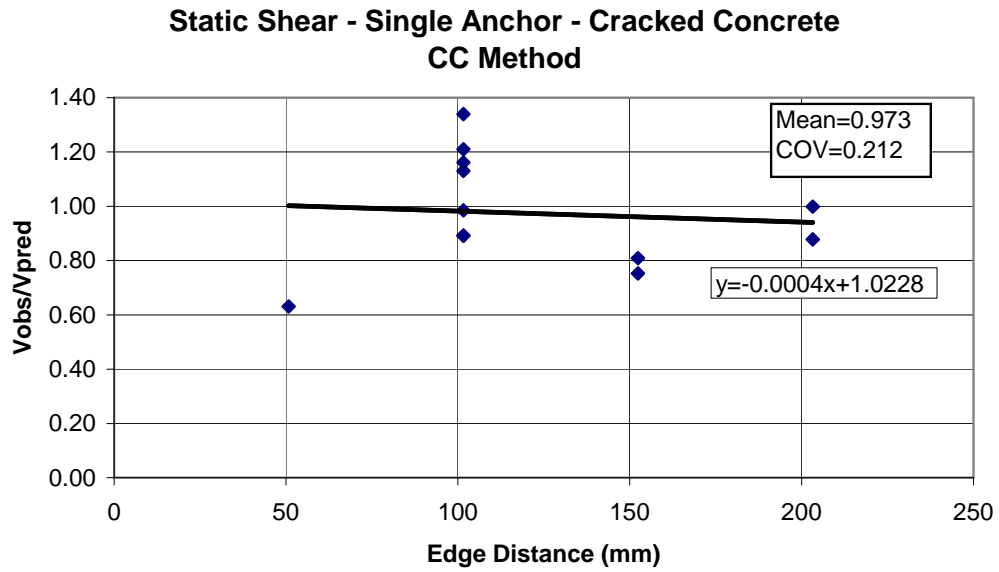

Figure 3.3 Ratios of Observed to Predicted Concrete Shear Breakout Capacities, CC Method (File: shear.xls, Sheet: s-1-c-s)

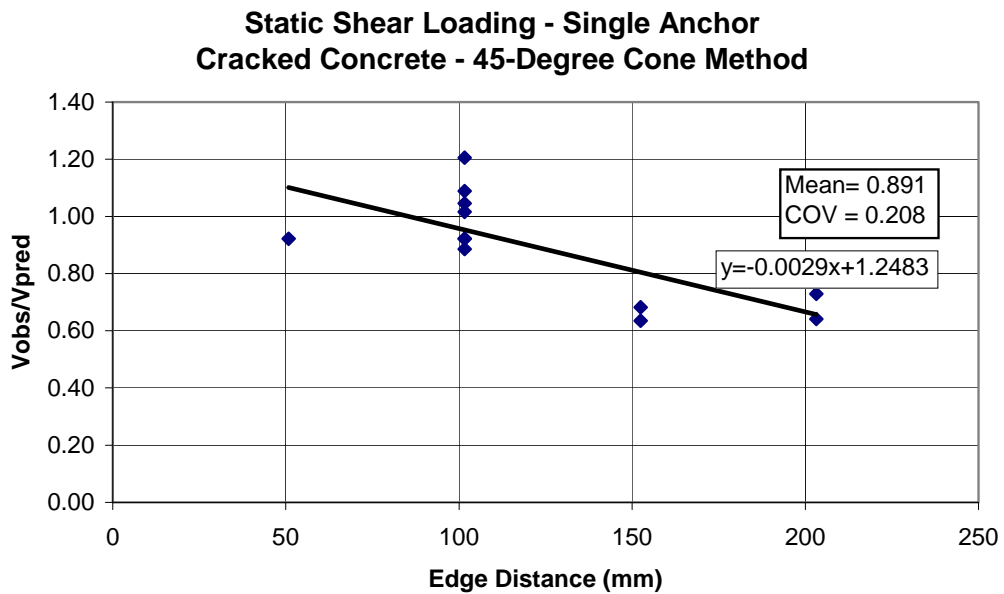

Figure 3.4 Ratios of Observed to Predicted Concrete Shear Breakout Capacities, 45-Degree Cone Method (File: shear.xls, Sheet: s-1-c-s)

Figure 3.4 shows the variation of ( $V_{obs}/V_{pred}$ ) with edge distance  $c_1$ , based on the 45-Degree Cone Method. The coefficient of variation is the same but the mean is lower, indicating that the 45-Degree Cone Method is unconservative for cracked concrete, especially when the edge distance is larger than 150 mm. As a result the best-fit line shows a significant systematic error.

### 3.6 SINGLE ANCHORS IN UNCRACKED CONCRETE UNDER DYNAMIC SHEAR LOADING

Data for this category are very limited, with a single edge distance of 4 inches. All tests are with CIP anchors and come from Hallowell (1996). Figure 3.5 shows the variation of ( $V_{obs}/V_{pred}$ ) with edge distance  $c_1$ , based on the CC

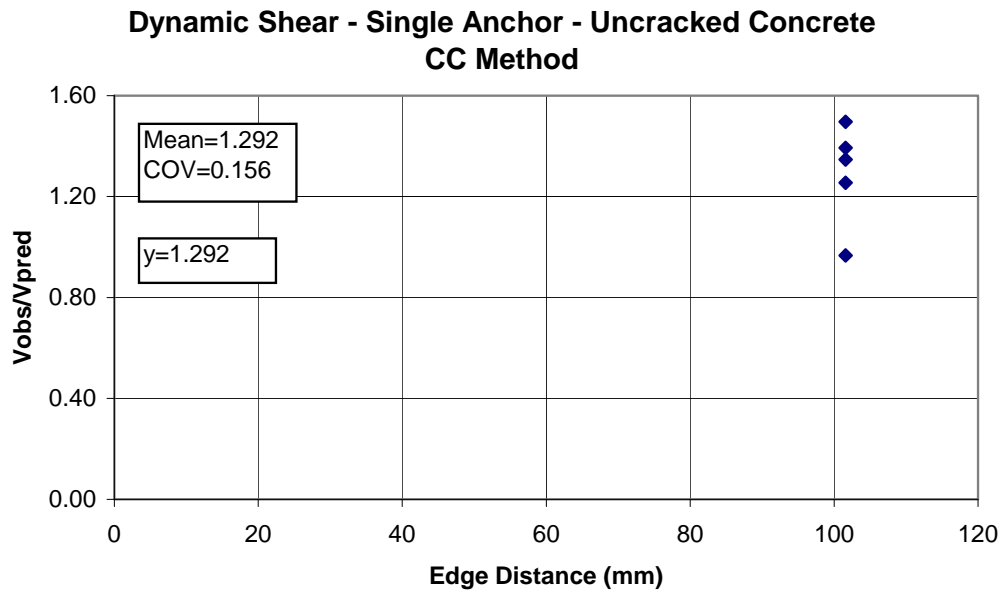

Figure 3.5 Ratios of Observed to Predicted Concrete Shear Breakout Capacities, CC Method (File: shear.xls, Sheet: s-1-u-d)

Method (Fuchs 1995). Comparing Figures 3.1 and 3.5, in uncracked concrete the shear capacity of CIP anchors increases by 1.20 when going from static load to dynamic load. No correction factor was used for the effects of dynamic loading in Equation (2-6). If a correction factor of 1.20 had been used, the mean values of ( $V_{obs}/V_{pred}$ ) would have been very close to 1.0. This implies that the CC Method (Fuchs 1995), including a correction factor of 1.20 for the effects of dynamic loading, would be quite satisfactory for the uncracked case. However, not enough data are available to support a definitive conclusion.

Figure 3.6 shows the variation of ( $V_{obs}/V_{pred}$ ) with edge distance  $c_1$ , based on the 45-Degree Cone Method.

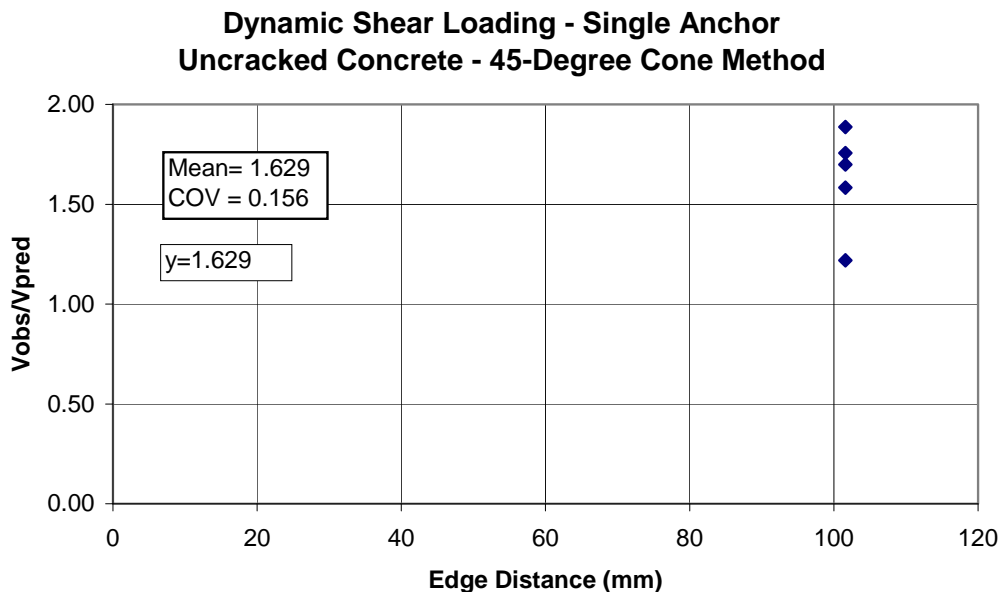

Figure 3. 6 Ratios of Observed to Predicted Concrete Shear Breakout Capacities, 45-Degree Cone Method (File: shear.xls, Sheet: s-1-u-d)

The mean of Figure 3.6 is 26% higher than that of Figure 3.5, indicating that the 45-Degree Cone Method is more conservative in the case of dynamic loading.

### 3.7 SINGLE ANCHORS IN CRACKED CONCRETE UNDER DYNAMIC SHEAR LOADING

Data for this category are very limited, with a single edge distance of 4 inches. All tests are with CIP anchors and come from Hallowell (1996). Figure 3.7 shows the variation of  $(V_{obs}/V_{pred})$  with edge distance  $c_1$ , based on the CC Method (Fuchs 1995). The mean value of  $(V_{obs}/V_{pred})$  for this case is quite high.

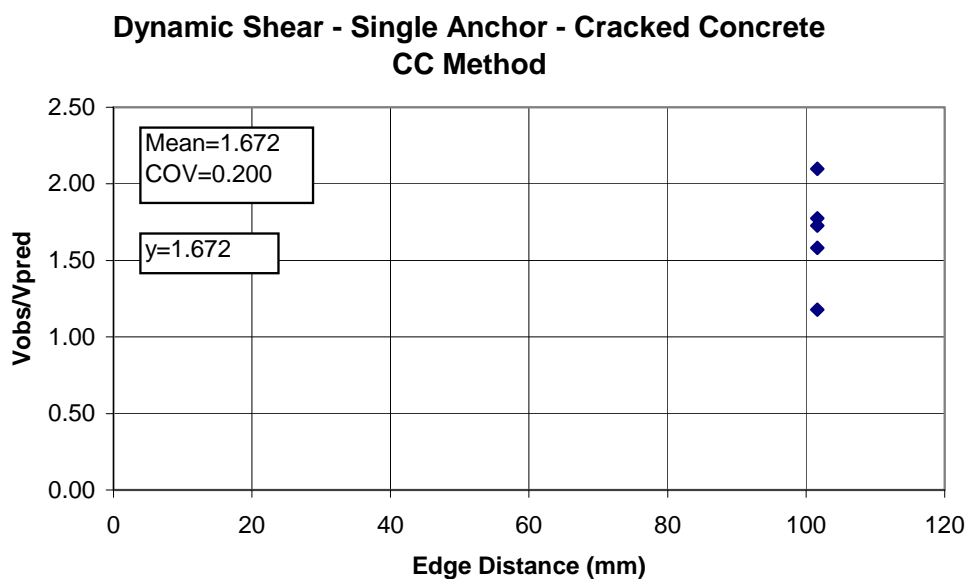

Figure 3.7 Ratios of Observed to Predicted Concrete Shear Breakout Capacities, CC Method (File: shear.xls, Sheet: s-1-c-d)

This also supports the use of a correction factor of 1.20 to Equation (2-6) for the effect of dynamic loading. Since such a factor has not been used in calculations comparing Figures 3.3 and 3.7, it suggests that in case of cracked concrete the shear capacity of Cast-In-Place anchors increases by 1.72 when going from static load to dynamic load. Another reason for this high value can be limited data for the case of dynamic loading in cracked concrete. An unexpected result is seen when Figures 3.5 and 3.7 are compared. It suggests that in the case of dynamic loading the concrete breakout capacity increases by 1.30 when going from uncracked concrete to cracked concrete. Again the reason for this can be the limited data in both categories.

Figure 3.8 shows the variation of ( $V_{obs}/V_{pred}$ ) with edge distance  $c_1$ , based on the 45-Degree Cone Method.

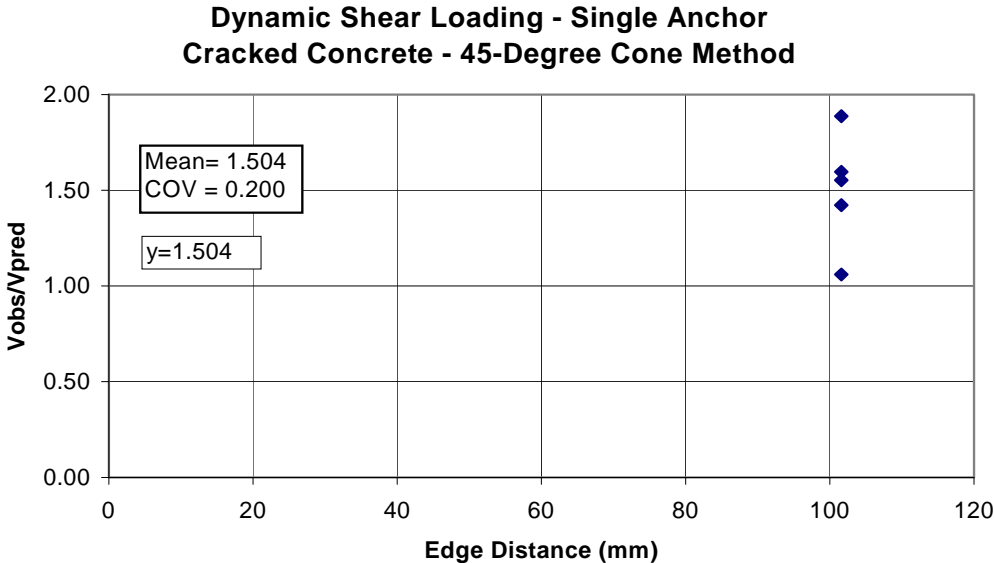

Figure 3. 8 Ratios of Observed to Predicted Concrete Shear Breakout Capacities, 45-Degree Cone Method (File: shear.xls, Sheet: s-1-c-d)

Comparing Figures 3.7 and 3.8 it is seen that the coefficients of variations are the same; however, the mean value for the 45-Degree Cone Method is lower than that of the CC Method, and is closer to 1.0. Actually both values are higher than expected, which can be due to the very limited number of tests in dynamic loading cases.

### 3.8 ALTERNATIVE FORMULA BASED ON REGRESSION ANALYSIS

As mentioned in the introduction, anchor capacities were also computed based on the results of a multivariate regression analysis for the data in Category (a). The basic concrete breakout capacity  $V_{no}$  is assumed to have the following form:

$$V_{no} = \alpha \cdot \ell^{m_1} \cdot d_o^{m_2} \cdot f_{cc}^{m_3} \cdot c_1^{m_4} \quad (3-1)$$

Then optimum values of  $\alpha$ ,  $m_1$ ,  $m_2$ ,  $m_3$ ,  $m_4$  are sought by multivariate regression analysis to minimize the error in  $V_{no}$ . The regression analysis is done by Excel. Taking logarithm of both sides of Equation (3.1) the right hand side becomes a linear function. Then linear regression capabilities of Excel is used to solve for  $\alpha$ ,  $m_1$ ,  $m_2$ ,  $m_3$ , and  $m_4$ . As a result of this analysis it is seen that the exponent of edge distance  $c_1$  is lower than 1.5. In addition to that coefficient of effective length  $\ell$  is lower than 0.2.

The results of multivariate regression analysis are presented in Table 3.2. Tables 3.3 and 3.4 present additional regression statistics: the coefficient of determination; F-statistics; and T-statistics. The coefficient of determination  $R_2$

indicates the level of correlation between the independent variables and  $V_{obs}$ . Values of  $R_2$  close to 1.0 indicate a stronger correlation. F-statistics can be used to determine whether these results with such a high value of  $R_2$  occur by chance. There is a strong relationship among the variables if the F-observed statistic is greater than the F-critical value, which can be obtained from a table of F-critical values. It is seen in Table 3.3 that  $R_2$  values are close to 1.0 and F-observed is greater than F-critical, implying that the results in Table 3.2 are not obtained by chance, and that there is a strong relationship among the variables  $\ell$ ,  $d_o$ ,  $f_{cc}$ ,  $c_1$  and the test results.

Table 3.2 Results of Multivariate Regression Analysis (File: shear.xls Sheet: Regression)

Data Type	$m_1$	$m_2$	$m_3$	$m_4$	$\alpha$
All Data	0.0443	0.5197	0.4126	1.2693	4.9183
All data Excluding $c_1 > 10''$	0.0540	0.6084	0.4481	1.3025	2.7100
All Normal Weight Concrete Data	-0.0029	0.5249	0.3949	1.3066	5.5272
All Normal Weight Conc. Data Excluding $c_1 > 10''$	-0.0006	0.6214	0.4530	1.3493	2.7270

Analysis summarized in Table 3.3 assumes a single-tailed test using an alpha value of 0.01. Alpha measures the probability of error in drawing a relationship between independent variables and  $V_{obs}$ .



Table 3.3 Summary of Regression Statistics

Data Type	R <sub>2</sub>	F-Statistics	
		F-Obs.	F-Crit.
All Data	0.923	267.750	3.560
All Data Excluding c <sub>1</sub> >10"	0.918	240.892	3.570
All Normal Weight Data	0.932	214.323	3.600
All Normal Weight Data Excluding c <sub>1</sub> >10"	0.928	190.160	3.610

Another test to determine whether each exponent value is useful in estimating V<sub>no</sub> is the T-statistic. The exponent is useful if the T-observed statistic is greater than the T-critical value, which can be obtained by referring to a table of T-critical values. In reading the table a single-tailed test is assumed using an alpha value of 0.05.

Table 3.4 Summary of T Statistics

Data Type	T-statistics									
	α		m <sub>1</sub>		m <sub>2</sub>		m <sub>3</sub>		m <sub>4</sub>	
	T Obs.	T Crit.	T Obs.	T Crit.	T Obs.	T Crit.	T Obs.	T Crit.	T Obs.	T Crit.
All Data	3.200	1.660	0.746	1.660	3.744	1.660	3.911	1.660	26.44	1.66
All Data Excluding c <sub>1</sub> >10"	1.789	1.660	0.909	1.660	4.100	1.660	4.219	1.660	26.10	1.66
All Normal Weight Data	2.934	1.670	0.041	1.670	3.299	1.670	3.097	1.670	24.29	1.67
All Normal Weight Data Excluding c <sub>1</sub> >10"	1.549	1.670	0.085	1.670	3.666	1.670	3.542	1.670	24.18	1.67

The T Statistics analysis results in Table 3.4 suggest that most values for exponents and for the correction factor  $\alpha$  in Table 3.2 can be used to estimate the basic concrete breakout capacity. The exception is  $m_1$ , the exponent for  $\ell$ , which is not reliably determined by this regression procedure. The final values of  $\alpha$ ,  $m_1$ ,  $m_2$ ,  $m_3$ , and  $m_4$  are not exactly as in Table 3.2, since those values were computed using only tests in uncracked concrete under static shear load. Considering all data categories and slightly modifying the values in Table 3.2 for design convenience and to obtain the best results, it was decided to use the following values:  $\alpha = 2.7$ ;  $m_1 = 0.1$ ;  $m_2 = 0.3$ ;  $m_3 = 0.5$ ; and  $m_4 = 1.4$ :

$$V_{no} = 2.7 \cdot \ell^{0.1} \cdot d_o^{0.3} \cdot f_{cc}^{0.5} \cdot C_1^{1.4} \quad (3.2)$$

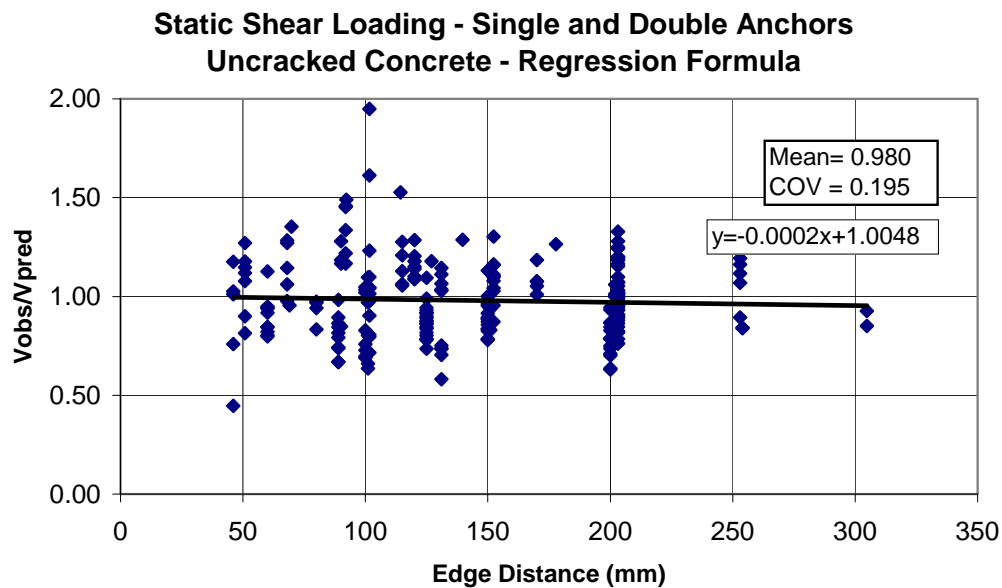

Figure 3. 9 Ratios of Observed to Predicted Concrete Shear Breakout Capacities, Regression Formula (file: shear.xls Sheet: Regression)

The variation of ( $V_{\text{obs}}/V_{\text{pred}}$ ) based on Equation (3.2) is presented in Figure 3.9. The best-fit line has a lower slope than the analysis based on the CC Method. Furthermore the mean ratio is closer to 1.0, and the COV is lower than for the CC Method.

The results for all categories using the CC Method, the 45-Degree Cone Method and the Regression Formula are summarized in Figures 3.10 and 3.11.

### Comparison of Mean Values for Vobs/Vpred

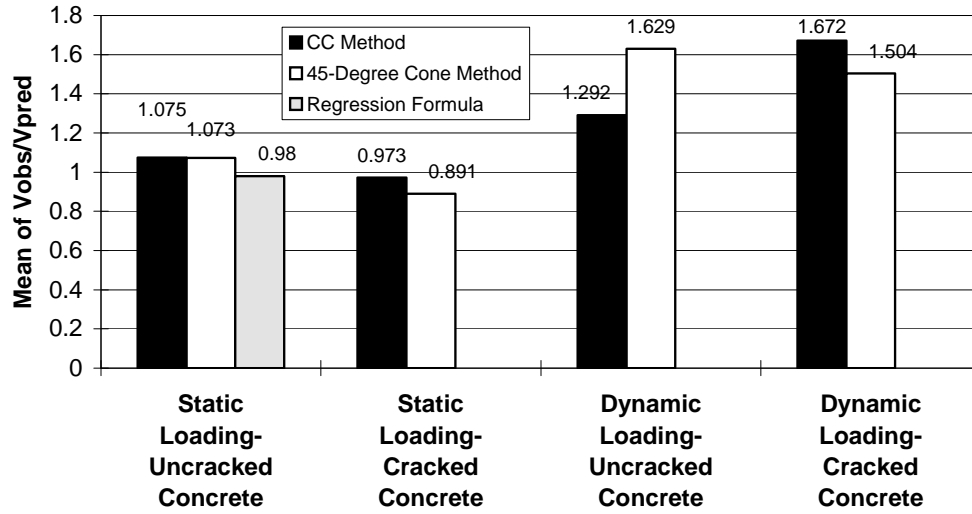

Figure 3. 10 Comparison of Mean Values for  $(V_{obs}/V_{pred})$  for Different Methods

Finally, the data in Category (a) (static shear loading, single and double anchors in uncracked concrete) were separated according to the anchor type to see if there is any difference in behavior between cast-in-place and post-installed anchors. Both anchor types were analyzed with three methods: the CC Method; the 45-Degree Cone Method; and the Regression Formula. The results are presented in Figures 3.12 through 3.17.

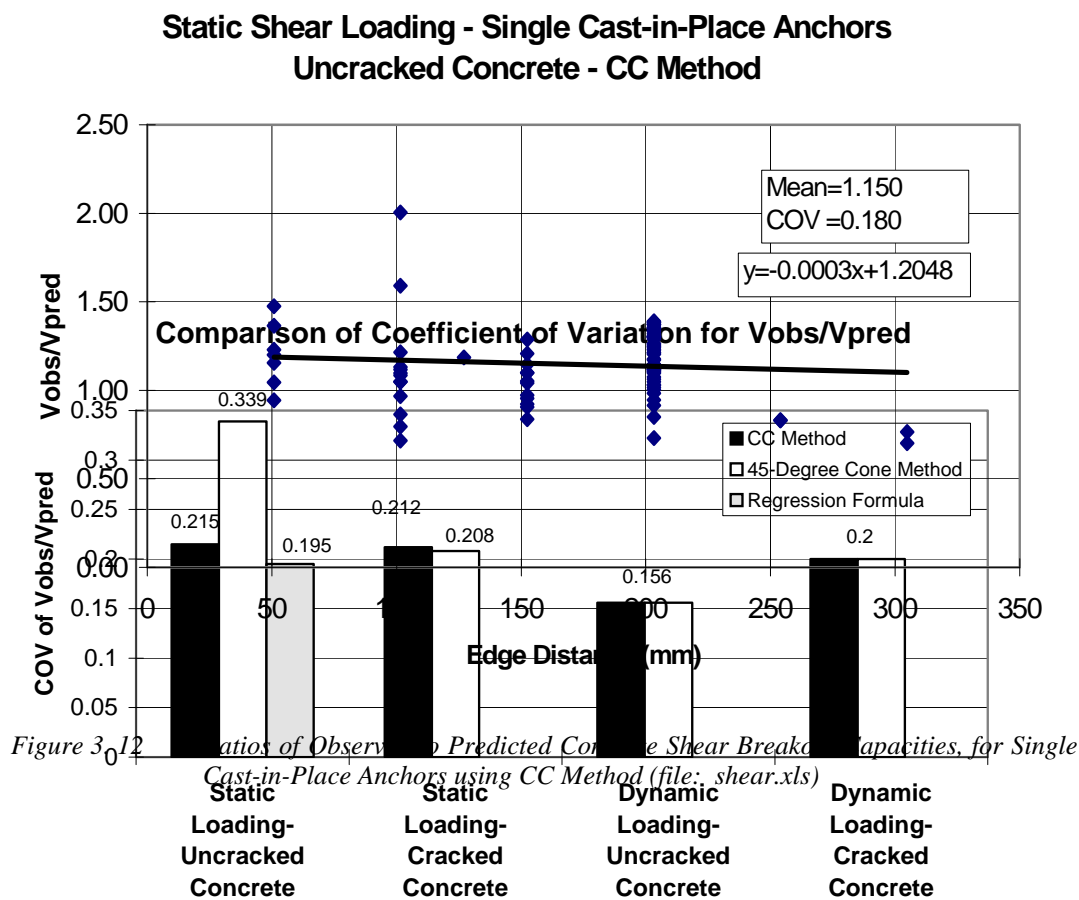

Figure 3.12 Comparison of Observed to Predicted Concrete Shear Breakout Capacities, for Single Cast-in-Place Anchors using CC Method (file: shear.xls)

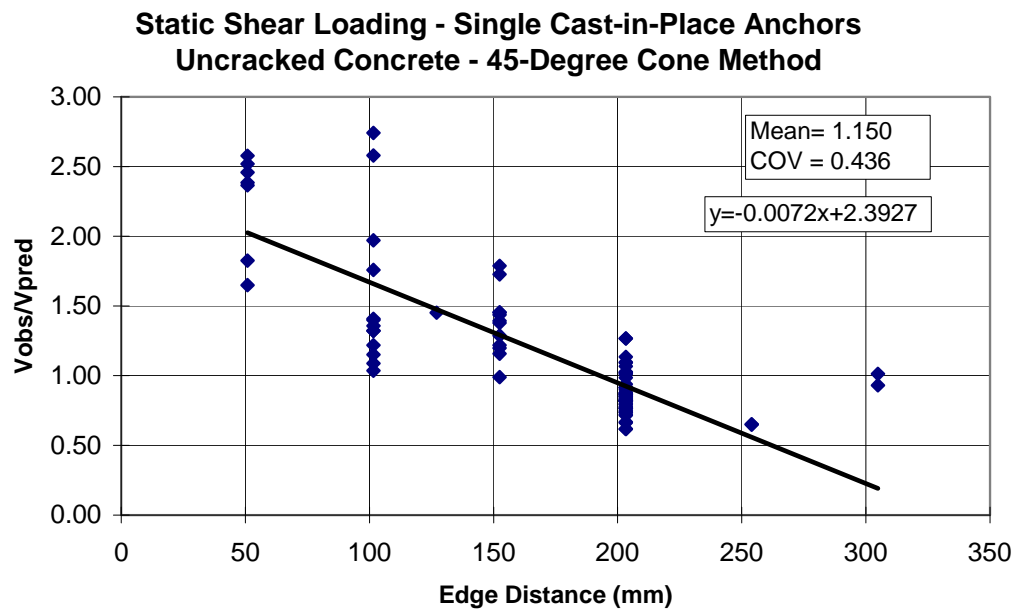

Figure 3.14 Ratios of Observed to Predicted Concrete Shear Breakout Capacities, for Single Cast-in-Place Anchors using 45-Degree Cone Method (file: shear.xls)

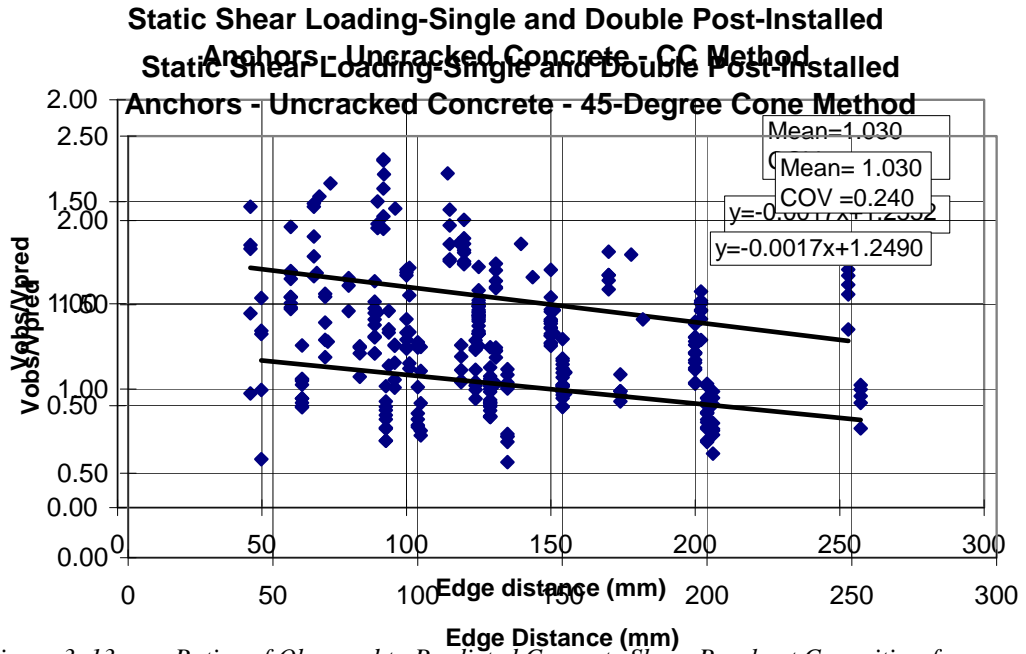

Figure 3.13 Ratios of Observed to Predicted Concrete Shear Breakout Capacities, for Single and Double Post-Installed Anchors using CC Method (file: shear.xls)

Figure 3.15 Ratios of Observed to Predicted Concrete Shear Breakout Capacities, for Single and Double Post-Installed Anchors using 45-Degree Cone Method (file: shear.xls)

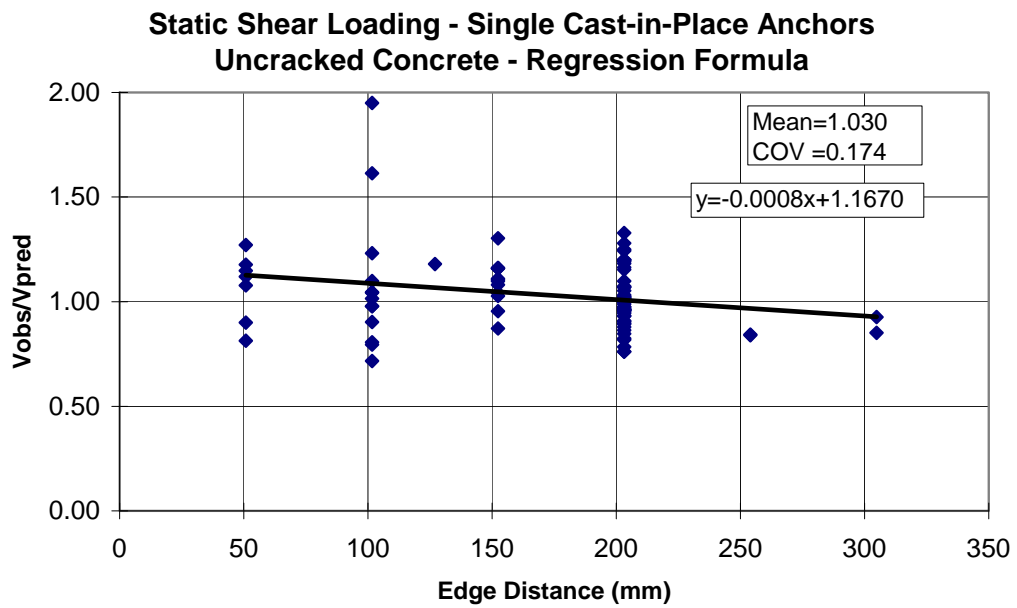

Figure 3.16 Ratios of Observed to Predicted Concrete Shear Breakout Capacities, for Single Cast-in-Place Anchors using Regression Formula (file: shear.xls)



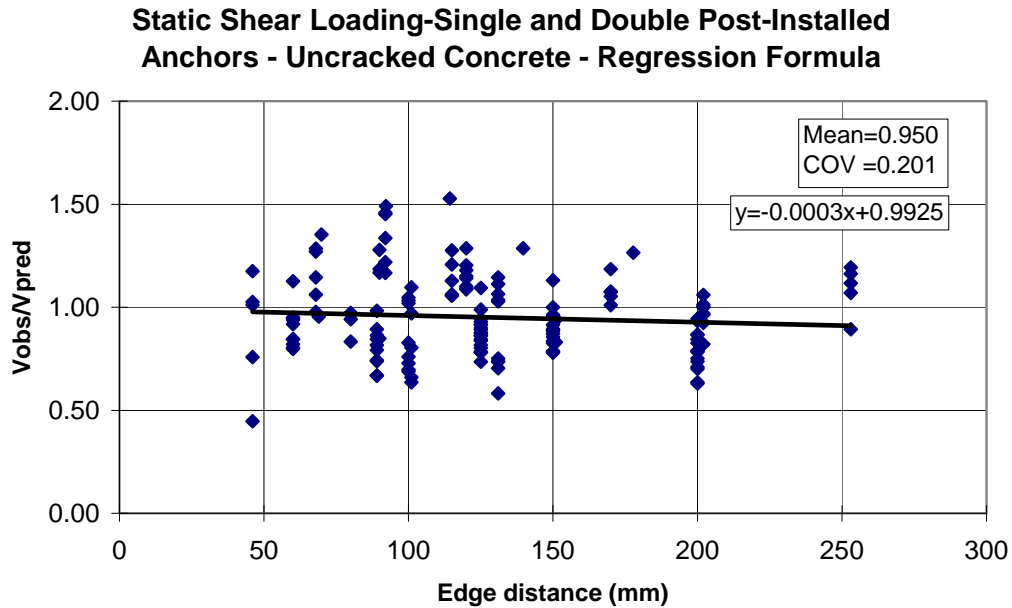

Figure 3.17 Ratios of Observed to Predicted Concrete Shear Breakout Capacities, for Single and Double Post-Installed Anchors using Regression Formula (File: shear.xls)

Evaluation of results for cast-in-place and post-installed anchors shows that the CC Method gives more reliable predictions over a wider range of edge distances for cast-in-place than for post-installed anchors (Figures 3.12 and 3.13). On the other hand, the CC method gives a 12% higher mean ratio ( $V_{obs}/V_{pred}$ ) for cast-in-place anchors than for post-installed anchors.

It is seen from Figure 3.14 that the 45-Degree Cone Method is very unreliable for cast-in-place anchors. It gives conservative results for edge distances less than 150 mm, and unconservative results for edge distances larger than 200 mm. Therefore the coefficient of variation is very high. Comparing Figures 3.13 and 3.15 it is seen that the 45-Degree Cone Method gives very

similar results to those of the CC Method for post-installed anchors. It gives even a lower coefficient of variation (0.189 vs. 0.228) for post-installed anchors if Maxibolt (1992) tests on undercut anchors are excluded.

Figures 3.16 and 3.17 show that the Regression Formula gives the most consistent results for both cast-in-place and post-installed anchors. Systematic error is lower than the other two methods for both anchor types. Some unconservative results have been observed for edge distances larger than 250 mm. However the data in this range are very limited, so it is not possible to make a reasonable conclusion on the performance of the Regression Formula for anchors with edge distances larger than 250 mm.

### **3.8 SUMMARY OF OBSERVATIONS AND EVALUATIONS**

- 1) The average shear breakout capacity of single anchors in uncracked concrete under static shear loading is predicted accurately by the CC Method over a wide range of edge distances ( $46 \text{ mm} < c_1 < 250 \text{ mm}$ ). For a few tests with edge distances larger than 250 mm, the CC Method is unconservative.

On the other hand, the 45-Degree Cone Method gives highly conservative results for edge distances less than 150 mm, but unconservative results for edge distances larger than 200 mm. This result is due to the fact that ACI 349 assumes failure load proportional to the square of edge distance,

whereas the CC method uses a lower exponent of 1.5 for the edge distance, considering the size effect.

- 2) The mean value of  $(V_{\text{obs}}/V_{\text{pred}})$  for static shear loading in cracked concrete has been found as 1.075 using the current form of the CC Method. The corresponding mean value for cracked concrete was 0.973. To correct the overestimated predictions of the CC Method for cracked concrete, the crack control factor  $\psi_6$  should be revised. The effective normalization constant “k” in the mean breakout shear capacity (Equation 2.5b) was taken 1.0 for uncracked concrete and 0.714 for cracked concrete. Comparing the mean values of  $(V_{\text{obs}}/V_{\text{pred}})$  for uncracked and cracked concrete, the true reduction in shear breakout capacity due to cracking is therefore:

$$\frac{0.714 \cdot 0.973}{1.075} = 0.65$$

Setting the normalization constant “k” to 1.075 to get the ideal condition of  $(V_{\text{obs}}/V_{\text{pred}}) = 1.0$  for uncracked concrete, the mean value of  $(V_{\text{obs}}/V_{\text{pred}})$  for cracked concrete reduces to

$$\frac{0.973}{1.075} = 0.905$$

To get the ideal condition of  $(V_{\text{obs}}/V_{\text{pred}}) = 1.0$  also for cracked concrete, k value for cracked case, which is given by  $\frac{k_{\text{uncracked}}}{\psi_6}$ , must decrease by

10%. This can be done by increasing  $\psi_6$  by 10% compared to its original value of 1.4. This means  $\psi_6$  should be as follows:

$$\psi_6 = 1.4 \cdot 1.10 = 1.54$$

This means that the normalization constant  $k$  for cracked concrete becomes

$$\frac{1.075}{1.54} = 0.70$$

- 3) Comparison of Figures 3.12 and 3.13 shows that in uncracked concrete under static shear load, the concrete breakout capacity of post-installed anchors by the CC Method is 10% lower than cast-in-place anchors. The same behavior is also seen by comparing Figures 3.14 and 3.15, where computations are based on the 45-Degree Cone Method. The results of the Regression Formula (Figures 3.16 and 3.17) also support the same conclusion. Therefore, predicted breakout capacity should be based on anchor type. This can be done by adjusting the normalization constant  $k$  for the basic uncracked concrete case for post-installed anchors as follows:

$$k_{\text{post-installed}} = 0.970$$

$$k_{\text{CIP}} = 1.075$$

Based on observations 2 and 3 above, Table 3.5 summarizes the modifications of the normalization constant  $k$  and comparison of capacities for different design approaches.

Table 3.5: Modifications on Normalization Constant “k” and corresponding  $\phi$ -factors for Different Design Approaches

Value	ACI 349 (Mean)	ACI 349 Ductile Design (5% fractile)	ACI 349 Brittle Design (5% fractile)
Normalization Constant k for Uncracked Concrete	1.07 CIP 0.97 Exp, UC	0.81 CIP 0.73 Exp, UC	0.81 CIP 0.73 Exp, UC
Strength Reduction Factor for Concrete Breakout	0.65	0.85	0.50
Design Capacity in Uncracked Concrete	0.70 CIP 0.63 Exp, UC	0.69 CIP 0.62 Exp, UC	0.40 CIP 0.36 Exp, UC
Normalization Constant k for Cracked Concrete	0.65	0.65	0.65
Design Capacity in Cracked Concrete	0.45 CIP 0.40 Exp, UC	0.45 CIP 0.46 Exp, UC	0.26 CIP 0.24 Exp, UC
Maximum Factored Design Load for Cracked Concrete	0.35 CIP 0.31 Exp, UC	0.34 CIP 0.30 Exp, UC	0.26 CIP 0.24 Exp, UC

- 4) Comparison of Figures 3.1 and 3.5 shows that concrete breakout capacity predicted by the CC Method increases by 20% when going from static to dynamic loading. Remembering that no factor is used in Equations (2-5b) and (2-6) to account for the effects of dynamic loading, this 20% increase in

capacity suggests that a factor of 1.20 will be quite satisfactory for dynamic loading in uncracked concrete.

- 5) Looking at Figures 3.5 and 3.6, it is seen that both the CC Method and the 45-Degree Cone Method give conservative results for dynamic loading in uncracked concrete ( $(V_{obs}/V_{pred}) > 1$  for all available tests). However, comparison of Figures 3.5 and 3.6 indicates that the mean value for  $(V_{obs}/V_{pred})$  based on the 45-Degree Cone Method is 25% higher than the CC Method for dynamic loading in uncracked concrete.
- 6) Comparing Figures 3.1 and 3.2, it is seen that the coefficient of variation for the 45-Degree Cone Method is 58% higher than for the CC Method (0.215 vs. 0.339). This is mostly due to underestimation of concrete breakout load using the 45-Degree Cone Method for edge distances less than 150 mm.
- 7) For cracked concrete under static shear loading, the coefficient of variation of  $(V_{obs}/V_{pred})$  for the 45-Degree Cone Method is the same as that of the CC Method but the mean is lower, especially for edge distances larger than 150 mm.
- 8) In all cases except that of dynamic shear loading in cracked concrete, concrete capacity is predicted more accurately by the CC Method than the 45-Degree Cone Method. The coefficient of variation for the CC Method

varies from 15 to 20 percent, what is equal or much below the typical coefficient of variation of concrete tensile strength.

- 9) When the CC Method is compared with the Regression Formula, the mean of  $(V_{\text{obs}}/V_{\text{pred}})$  is closer to 1.0 and the slope of the best-fit line is closer to zero, indicating less systematic error for the Regression Formula. This conclusion is only for static shear loading in uncracked concrete, because this is the only case where enough data are present for reliable regression analysis.
- 10) Maxibolt (1992) states that using the field and laboratory test data on concrete strength, a regression analysis between tensile and compressive strength of concrete yielded an exponent of 0.69 for  $f_c'$  to estimate the tensile strength. On the other hand current CC Method and the 45-Degree Cone Method assumes an exponent of 0.5 for  $f_c'$  to estimate tensile strength of the concrete. This means that both the current CC Method and the 45-Degree Cone Method would underestimate the concrete breakout load for the Maxibolt (1992) tests, which in turn would produce high values of  $(V_{\text{obs}}/V_{\text{pred}})$ .

# **CHAPTER FOUR**

## **STATISTICAL EVALUATION OF DATABASE**

### **USING A DUCTILE DESIGN APPROACH**

#### **4.1 INTRODUCTION**

To evaluate the accuracy and suitability of the CC Method, the 45-Degree Cone Method and the Regression Formula as design approaches, the probability of concrete cone failure under known loads and independent of load was computed. The statistical evaluation is carried out assuming the ductile design framework and current load and understrength factors of ACI 349-90, Appendix B (load factor=1.7;  $\phi = 0.85$  for steel;  $\phi = 0.65$  for concrete). Assuming the exact forms of load and capacity distributions, the probabilities of failure are computed using FORM (First Order Reliability) analysis. These calculations are based on a normal distribution for all variables.

#### **4.2 BASIC ASSUMPTIONS AND STEPS IN PROBABILITY ANALYSIS**

- 1) The statistical distribution of applied load is assumed normal with an arbitrary mean of 1.0 and an assumed coefficient of variation of 0.2 (Farrow 1996). No units are specified with this load distribution because the



distribution is independent of units. Since the load distribution curve will be used with steel and concrete resistance curves, units are not important as long as they are consistent with each other. Building codes commonly specify live loads at the 95-percentile value. In other words, the prescribed design value is greater than or equal to 95 percent of the observed values. Therefore the unfactored design load is assumed to be 95% fractile of the actual load. Assuming a normal distribution, this load corresponds to 1.645 standard deviations above the mean. The unfactored design load is therefore 1.329.

$$\text{Unfactored design load} = 1.0 + 0.2 \cdot 1.645 = 1.329 \quad (4.1)$$

- 2) Steel is selected so that steel capacity based on shear friction theory reduced by the appropriate  $\phi$ -factor, exceeds the factored design load. The minimum required steel resistance is equal to the design load (the 95% fractile of the load distribution, or 1.329), multiplied by the load factor for live load (1.7) and divided by the  $\phi$ -factor of ACI 349-90, Appendix B for steel (0.85). The minimum required steel resistance therefore has a mean value of 2.745.

$$f \cdot V_{ns} > V_d \quad (4.2)$$

$$V_{ns} = A_{vf} \cdot f_y \cdot \mu \quad (4.3)$$

$$0.85 \cdot A_{vf} \cdot 0.83 \cdot f_{ut} \cdot 0.7 > 1.7 \cdot 1.329$$

$$A_{vf} \cdot f_{ut} = 4.575$$

$$\text{Theoretical Steel Resistance} = 0.6 \cdot 4.575 = 2.745$$

- 3) To compute the mean and COV for the ratio of actual to predicted steel capacities under shear loading, a database composed of shear tests on single anchors is formed. The tests for this database are taken from Klingner (1982) and Lotze (1997). Test results were high for tests taken from Klingner (1982) because no tetrafluoroethylene (Teflon©) sheets were placed between the baseplate and concrete. Lotze's tests used such sheets. To use all tests together to estimate the mean and COV of the ratio of actual to predicted steel capacities, the shear taken by friction in the Klingner tests was estimated as follows:

First, a database for 56 tension tests with steel failure was formed (Appendix E). The mean value for the ratio of observed to predicted tensile capacities ( $N_{\text{obs}}/N_{\text{pred}}$ ) is found to be 1.50. For tests of Klingner (1982) the mean value of the ratio of observed to predicted shear strength ( $V_{\text{obs}}/V_{\text{pred}}$ ) can be represented as:

$$\frac{V_{\text{obs}}}{V_{\text{pred}}} = \frac{V_f + V_s}{V_{\text{ns}}} \quad (4.4)$$

where:

$V_f$  = shear taken by friction

$V_s$  = shear taken by anchor steel

In the tests of Klingner (1982), the mean value of ( $V_{obs}/V_{pred}$ ) is 1.979 (Appendix E). Assuming that mean ratios of observed to predicted capacities of anchor steel in tension and in shear are equal [that is ( $V_{obs}/V_{pred}) = (N_{obs}/N_{pred})=1.50$ ], the shear taken by friction in the tests of Klingner (1982) can be estimated as:

$$\begin{aligned}\frac{V_f}{V_{ns}} + \frac{V_s}{V_{ns}} &= 1.979 \\ \frac{V_f}{V_{ns}} + 1.50 &= 1.979 \\ \frac{V_f}{V_{ns}} &= 0.479\end{aligned}$$

where  $V_{ns}$  is the nominal shear capacity of the steel, given by:

$$V_{ns} = 0.6 \cdot A_{eff} \cdot f_{ut} \quad (4.5)$$

The test results for Klingner (1982) without friction effect is calculated as:

$$\begin{aligned}V'_{obs} &= V_{obs} - V_f \\ V'_{obs} &= V_{obs} - 0.479 \cdot (0.6 \cdot A_{eff} \cdot f_{ut})\end{aligned} \quad (4.6)$$

Test results of Klingner (1982) without friction is then combined with tests from Lotze (1996). The mean and COV for the ratio of actual to predicted steel capacity for shear are calculated as 1.28 and 0.180, respectively.

- 4) The actual mean steel resistance is calculated by multiplying the theoretical required capacity (2.745) by the ratio of actual to predicted steel capacity, 1.28. The actual mean steel resistance is therefore  $2.745 \cdot 1.28 = 3.514$ .
- 5) According to the provisions of ACI 349-90, Appendix B, the minimum edge distance for shear loading toward a free edge shall be such that the concrete design strength exceeds the ultimate shear strength of bolts, studs, or bars. This means that required nominal capacity of anchors as governed by concrete breakout, reduced by a  $\phi$ -factor of 0.65, must be at least equal to the minimum specified ultimate shear strength of the anchor steel. Thus, the required nominal capacity of the anchor as governed by concrete breakout failure is 2.745, increased by the reciprocal of the  $\phi$ -factor for concrete (0.65). The required nominal concrete breakout capacity is therefore

$$\text{Required nominal concrete capacity} = 2.745 \cdot \frac{1}{0.65} = 4.223$$

- 6) The actual mean concrete breakout capacity is calculated by multiplying the required nominal capacity (4.223) by the ratio of actual to predicted capacity. The breakout capacity ratios were computed for each anchor category separately, as presented in the discussion of results in this thesis.
- 7) The probability of anchor failure under assumed loads is computed based on FORM analysis using the computer program VaP (1990). This probability

is computed as the summation of the probability of steel failure and the probability of concrete failure.

- 8) The probability of concrete failure independent of load is computed similarly. This represents the probability that the anchor will fail by concrete breakout rather than steel fracture. This case is particularly useful in situations where the applied load is difficult or impossible to estimate.

The results of statistical analysis are presented both in Tables 4.1 and 4.2, and in Figures 4.1 and 4.2.

Table 4. 1 Probabilities of Failure under Known Loads for Different Categories of Shear Anchors, Ductile Design Approach

ANCHOR CATEGORY	CC METHOD		45-Degree CONE METHOD		REGRESSION METHOD	
	Probability of Failure	$\beta$	Probability of Failure	$\beta$	Probability of Failure	$\beta$
Single and Double Anchors, Uncracked Concrete, Static Shear Loading	2.665E-04	3.55	1.138E-02	2.28	1.56E-04	3.77
Single Anchors, Cracked Concrete, Static Shear Loading	3.275E-04	3.48	3.885E-04	3.42	--	--
Single Anchors, Uncracked Concrete, Dynamic Shear Loading	7.567E-05	5.10	7.554E-05	5.39	--	--
Single Anchors, Cracked Concrete, Dynamic Shear Loading	8.620E-05	4.25	9.130E-05	4.16	--	--

Table 4. 2 Probabilities of Brittle Failure Independent of Load for Different Categories of Shear Anchors, Ductile Design Approach

ANCHOR CATEGORY	CC METHOD		45-Degree CONE METHOD		REGRESSION METHOD	
	Probability of Failure	$\beta$	Probability of Failure	$\beta$	Probability of Failure	$\beta$
Single and Double Anchors, Uncracked Concrete, Static Shear Loading	0.189	0.88	0.270	0.61	0.271	0.61
Single Anchors, Cracked Concrete, Static Shear Loading	0.290	0.55	0.402	0.25	--	--
Single Anchors, Uncracked Concrete, Dynamic Shear Loading	0.034	1.83	0.003	2.70	--	--
Single Anchors, Cracked Concrete, Dynamic Shear Loading	0.011	2.29	0.023	2.00	--	--

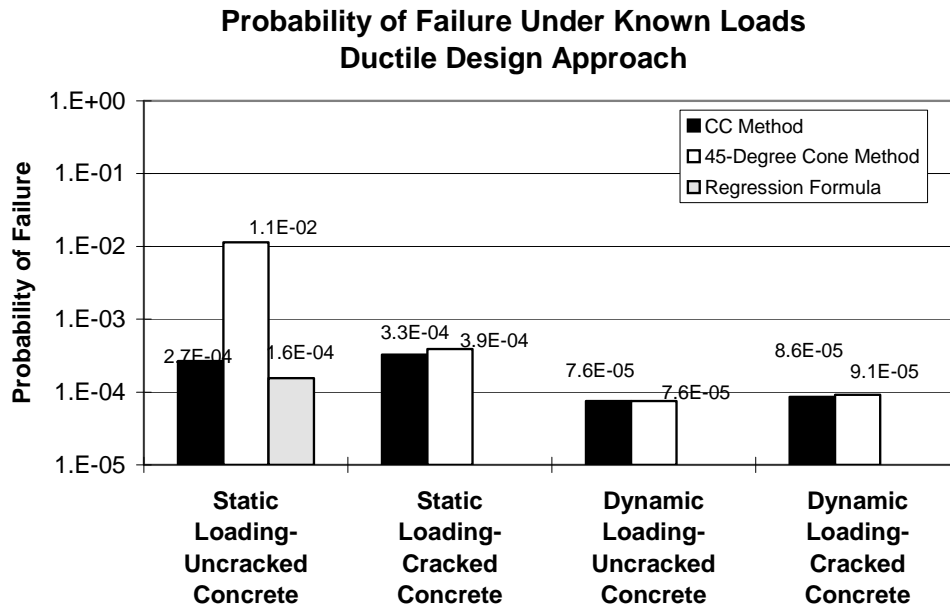

Figure 4. 1 Probabilities of Failure under Known Loads

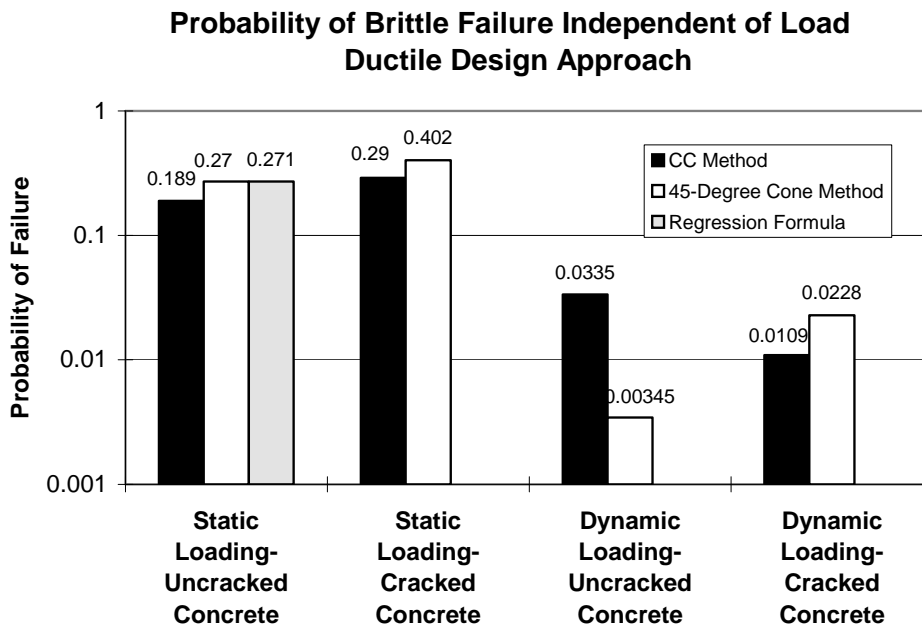

Figure 4. 2 Probabilities of Brittle Failure Independent of Load



### **4.3 GENERAL LIMITATIONS OF THE STATISTICAL ANALYSIS**

- 1) Normal distributions are assumed for both load and resistance. The safety index  $\beta$  can increase or decrease for different assumptions.
  
- 2) Actual concrete strength is assumed equal to the specified strength. The actual concrete strength usually exceeds that specified. Inclusion of the difference between actual and specified concrete strengths tends to increase the mean of  $(V_{\text{obs}}/V_{\text{pred}})$ . However, it also increases the scatter of the results, because another random variable has been introduced into the problem.
  
- 3) Results of the above analysis for tests under dynamic loading are not statistically significant, because of very limited data available.

## **CHAPTER FIVE**

### **SUMMARY, CONCLUSIONS, AND RECOMMENDATIONS**

#### **5.1 SUMMARY**

In this thesis, basic principles and design guidelines in documents such as the draft proposal for ACI 318 (Chapter 23), the draft proposal for ACI 349 (Chapter 23), USI A-46 SQUG Report, and the ACI 355 State of the Art Report were first reviewed. Second, a database of existing data on shear anchors was established. The database is divided into four main categories according to the type of loading (static or dynamic), and condition of concrete before the test (cracked or uncracked). As a result, the effects of load type and concrete condition on concrete breakout capacity in shear could be investigated. The concrete breakout capacity of anchors in each category is then compared with the predictions by the CC Method and the 45-Degree Cone Method. Evaluations are made using linear regression analysis. The accuracy and suitability of the CC Method and the 45-Degree Cone Method are also evaluated assuming the ductile design framework of ACI 349-90, Appendix B. Finally some design recommendations and modifications are proposed for the effects of dynamic loading, cracking, anchor type and some changes in formulas for estimating shear capacity as governed by concrete breakout.

## 5.2 CONCLUSIONS FROM STATISTICAL ANALYSIS

The CC Method is more reliable than the 45-Degree Cone Method as a design tool. It can be safely used for design of cast-in-place and post-installed anchors for edge distances up to 250 mm. However some modifications can be made to increase the accuracy of the CC Method, based on whether the loading is dynamic or static, the concrete is cracked or uncracked, and the anchor is cast-in-place or post-installed. The ductile design approach in the draft proposal for ACI 349 (Appendix F in this thesis) provides a safe and efficient design method for fasteners in concrete. The following modifications are proposed for the shear design and evaluations of fasteners in concrete.

## 5.3 RECOMMENDATIONS FOR DESIGN AND EVALUATION

- 1) The CC Method gives more accurate estimates of concrete breakout capacity than 45-Degree Cone Method. However, the better performance of the Regression Formula suggests that in the CC Method, the exponent of the edge distance  $c_1$  should be lowered to 1.4. Therefore Equation (23-19a) in the draft ACI 349 should be changed as follows:

$$V_b = 7 \cdot \left(\frac{\ell}{d_o}\right)^{0.2} \cdot \sqrt{d_o} \cdot \frac{\sqrt{f'_c}}{\lambda} \cdot c_1^{1.4} \text{ (lb)} \quad \text{Modified draft ACI 349 Eq.(23.19a)}$$

- 2) Comparing Figures 3.1 and 3.5, the capacity of cast-in-place anchors increases by 20% under dynamic loading compared to static loading. This

can be introduced into the draft ACI 349 by inserting a new factor  $\psi_7 = 1.2$ .

$$V_{b_{\text{dyn}}} = 1.2 \cdot V_{b_{\text{static}}} \quad \text{Add to the draft ACI 349 as Equation (23.19c)}$$

- 3) Section 3.3 on page 28 discusses the current normalization constant  $k$  and the  $\phi$ -factor for different design approaches in the draft proposal for ACI 349. To correct the overestimated predictions of the CC Method for cracked concrete and to obtain a mean value of  $(V_{\text{obs}}/V_{\text{pred}}) = 1.0$  for both cracked and uncracked cases, the normalization constant “ $k$ ” for uncracked concrete should be changed to 1.075 and the crack control factor  $\psi_6$  should be 1.54. Details are given in comment (2) of Section 3.8 of this thesis. In summary, the shear breakout capacity formulas (Equation 2.5b and 2.6) should be modified as follows:

$$\begin{aligned} k &= 1.075 \\ \psi_6 &= 1.54 \quad \text{for uncracked concrete} \end{aligned}$$

- 4) The concrete breakout capacity of post-installed anchors is 10% lower than that of cast-in-place anchors. Therefore, predicted breakout capacity should be based on anchor type. This can be done by adjusting the mean normalization constant  $k$  to 0.97 for the basic uncracked concrete case for post-installed anchors.

Modifications on the normalization constant “k” based on Recommendations 3 and 4, and on comparison of capacities for different design approaches are given in Table 3.5 of Section 3.8 of this thesis.

### **5.3 RECOMMENDATIONS FOR FUTURE RESEARCH**

- 1) Few tests are available for single-and multiple-anchor connections in cracked concrete under dynamic loading. Therefore it is difficult to draw firm conclusions regarding the effect of dynamic loading in cracked concrete. More tests are necessary in uncracked concrete under dynamic loading.
- 2) Only a few tests are available on single anchors in uncracked and cracked concrete, close to two free edges. More such test results are needed.
- 3) This thesis did not cover tests on multiple anchors loaded with eccentric shear. To understand how anchors share shear load, failure modes and the capacity of such connections it is needed to do more tests and the accompanying analysis.

## REFERENCES

ACI 318 (1995): Committee 318, "Building Code Requirements for Structural Concrete," American Concrete Institute, Detroit, Michigan, 1990.

ACI 349 (1990): ACI 349 1990, "Code Requirements for Nuclear Safety Related Concrete Structures," American Concrete Institute, Detroit, Michigan, 1990.

CEB 206&207 (1991): Comité' Euro-International du Béton, *Fastening to Reinforced Concrete and Masonry Structures: State-of-the-Art-Report*, bulletin D'Information Nos.206 and 207, August 1991.

Cook (1989): Cook, Ronald A., "Behavior and Design of Ductile Multiple-Anchor Steel-to-Concrete Connections," Ph.D. Dissertation, The University of Texas at Austin, May 1989.

Farrow, Friqui, and Klingner (1996): Farrow, C. B., Friqui, I., and Klingner, R. E., "Tensile Capacity of Single Anchors in Concrete: Evaluation of Existing Formulas on an LRFD Basis," *ACI Structural Journal*, Vol. 93, No. 1, January-February 1996, pp. 128-137.

Fuchs (1995): Fuchs Werner, Eligehausen Rolf, and Breen John E., "Concrete Capacity Design (CCD) Approach for Fastening to Concrete," *Journal of the American Concrete Institute*, Vol. 92, No. 1, January-February 1995, pp. 73-94.

Hallowell (1996): Hallowell, Jennifer, "Tensile and Shear Behavior of Anchors in Uncracked and Cracked Concrete Under Static and Dynamic Loading," M.S. Thesis, The University of Texas at Austin, December 1996.

Klingner (1982): Klingner, R. E. and Mendonca, J. A., "Shear Capacity of Short Anchor Bolts and Welded Studs: A Literature Review," *Journal of the American Concrete Institute*, Proceedings Vol. 79, No. 5, September-October 1982, pp. 339-349.

Klingner (1997): Klingner, R. E., "Memorandum to Ad-Hoc Task Group on Headed Anchor Data," May 13, 1997.

Lotze (1996): Lotze, Dieter, "Behavior of Multiple Anchor Connections to Concrete from Perspective of Plastic Theory," *PMFSEL Report No. 96-4*, March 1997.

Maxibolt (1992): *Arkansas Nuclear One Maxibolt Anchor Bolt Test Program*, Entergy Operations, Inc. Arkansas Nuclear One Steam Electric Station, MCS Design, May 14, 1992.

VaP (1990): Petschacher, Markus, "A Statistical Analysis Software for Engineers," *Institute of Structural Engineering IBK*, ETH Zurich, Switzerland.

Zhang (1997): Zhang, Yonggang, "Dynamic Behavior of Multiple Anchor Connections," Ph.D. Dissertation, The University of Texas at Austin, May 1997.

The following materials were read but not cited in this thesis.

"Concrete Expansion Anchor Static Tension Tests," *Technical Report by Wiss, Janney, Elstner and Associates, Inc. for Bechtel Power Corporation*, March 1982.

"Concrete Expansion Anchor Torque-Tension Tests Using Load Cell Instrumentation," *Technical Report by Wiss, Janney, Elstner and Associates, Inc. for Bechtel Power Corporation*, November 1981.

"Concrete Expansion Anchor Torque-Tension Tests Using Hydraulic Ram and Strain Gage Instrumentation," *Technical Report by Wiss, Janney, Elstner and Associates, Inc. for Bechtel Power Corporation*, January 1982.



“Dynamic Qualification Tests of 1-1/4 Inch Diameter Hilti Super Kwik Bolts,” *Research Report by Edwin G. Burdette*, The University of Tennessee, Knoxville, Tennessee, August 1983.

“Drilled-In Expansion Bolts Under Static and Alternating Load,” *Technical Report by Bechtel Power Corporation for Hanford Engineering Development Laboratory, Richland, Washington*, January 1975.

“Drilled-In Expansion Bolts Under Static and Alternating Load,” *Technical Report by Bechtel Power Corporation for Hanford Engineering Development Laboratory, Richland, Washington*, October 1976.

“Expansion Anchor Installation in Concrete Unit Masonry for Susquehanna Steam Electric Station,” *Technical Criteria*, Bechtel Power Corporation San Francisco, California June 12 1980.

“Hilti Kwik-Bolt Concrete Expansion Anchor Torque/Tension Tests,” *Conducted by Hilti Inc. for Dravo Construction at Susquehanna Steam Electric Station*, March/April 1986.

“Report on Hilti Drop-In Expansion Anchor Tests for Torque/Tension Relationship and Tension Capacity,” Bechtel Associates Professional Corporation, Ann Arbor, Michigan, August 1980.

“Report on the Testing of Concrete Expansion Anchors and Grouted Anchors and Grouted Anchor Installed in Concrete Blockwalls,” Bechtel Associates Professional Corporation, Ann Arbor, Michigan, August 1980.

“Results and Evaluation of Tests on Phillips ‘Red Head’ Self-Drilling Expansion Anchors,” *Technical Report for Consumers Power Company Palisades Plant, South Haven, Michigan*, January 1980.

“Shear Embedments Test Program,” *Job No. 90116*, Bechtel Power Corporation San Francisco, California 1975.

“Static and Dynamic Test Program for Concrete Expansion Anchor,” Commonwealth Edison Company of Illinois, August 1981.

“Technical Specification for Testing Stud Type Concrete Expansion Anchors for The Consumers Power Company,” Bechtel Associates Professional Corporation, December 1981.

“Tests of A325 Bolts Anchored to Richmond Bolt Couplers,” *Research Report by Edwin G. Burdette*, The University of Tennessee, Knoxville, Tennessee, August 1981

“Test Report about the Dynamic Testing of Hilti Kwik Bolt, sizes 3/4” and 1”,” *Hohere Technische Bundes- Lehr- und Versuchsanstalt, Rankweil*, December 21, 1981

“Test Report about the Dynamic Testing of Hilti Kwik Bolt, sizes 1/2” and 5/8”,” *Hohere Technische Bundes- Lehr- und Versuchsanstalt, Rankweil*, December 21, 1981

## **VITA**

Hakki Muratli was born in Konya, Turkey on February 2, 1970, the son of Sevket Muratli and Muazzez Muratli. After graduating with high honors from Ataturk Anadolu Lisesi in Ankara, he entered the Middle East Technical University in Ankara majoring in Civil Engineering. He was awarded the degree of Bachelor of Science with high honors from that institution in June 1993. In August 1996 he began graduate study in the Department of Civil Engineering at the University of Texas at Austin. He was awarded a Turkish Ministry of National Education graduate scholarship for his two-year graduate study there.

Permanent Address: Oyak Sitesi 14. Giris Daire 23  
Cankaya-Ankara-TURKEY

This thesis was typed by the author.