

1. Report No. <i>FHWA/TX-95+1309-1F</i>		2. Government Accession No.		3. Recipient's Catalog No.	
4. Title and Subtitle <i>EVALUATION OF FAILURE IN BRIDGE EXPANSION JOINT RAILS</i>				5. Report Date <i>October 1994</i>	
				6. Performing Organization Code	
7. Author(s) <i>V. Dolan and K. H. Frank</i>				8. Performing Organization Report No. <i>Research Report 1309-1F</i>	
9. Performing Organization Name and Address <i>Center for Transportation Research The University of Texas at Austin 3208 Red River, Suite 200 Austin, Texas 78705-2650</i>				10. Work Unit No. (TRAVIS)	
				11. Contract or Grant No. <i>Research Study 0-1309</i>	
12. Sponsoring Agency Name and Address <i>Texas Department of Transportation Research and Technology Transfer Office P. O. Box 5080 Austin, Texas 78763-5080</i>				13. Type of Report and Period Covered <i>Final</i>	
				14. Sponsoring Agency Code	
15. Supplementary Notes <i>Study conducted in cooperation with the U.S. Department of Transportation, Federal Highway Administration Research Study Title: "Evaluation of Failure in Bridge Expansion Joint Rails"</i>					
16. Abstract <p><i>Strip seal expansion joint systems are composed of two structural parts; the rail and the concrete deck. Failures of expansion joints can be due to failures of either one of these components or a combination of both. The results of this investigation have indicated that the failure of the expansion joints in McAllen was due to a failure in the concrete part of the system. This failure resulted in unintended loads on the anchorage studs leading to the observed joint failures.</i></p> <p><i>Testing of the rail sections, studs and welds showed no predisposition of the rails to failure. The steel makeup and stud welding appeared to be of uniform consistency and acceptable quality. Although failure of the expansion joints expresses itself in the rails and studs, this is a secondary effect which is induced by problems with the concrete placement.</i></p> <p><i>Failure of the concrete was due to the lack of complete concrete consolidation under the rail. Incomplete consolidation of the concrete is attributed to several factors including: lack of weep holes, form placement and pouring sequence. Weep holes in the top flange of the rail are necessary to allow for excess air and bleed water to escape from underneath the rail. The holes also act as a method of quality assurance. The presence of concrete in these holes after concrete placement indicates the presence of concrete under the rail. Correct form placement at the ends of the slab is necessary so that concrete is present under the lower lip of the vertical flange. Pouring sequence of the slab is also an important factor to consider when using strip seal expansion joints, especially on sloped bridges. The pouring sequence used on the McAllen bridges was typically downhill. By starting concrete placement at the highest point and proceeding to the lowest there is a possibility that the plastic concrete will flow downhill. This flow will pull concrete away from the inside of the rail and result in detrimental voids. Consideration to the concrete flow problem should be given when deciding on concrete pouring sequences and consolidation practices. Congestion of the slab reinforcement at the rail, aggravates proper placement of the concrete. The spacing between the bars should follow the standard practices regarding reinforcing steel spacing.</i></p>					
17. Key Words <i>expansion joints, strip seal expansion joint systems, rail section, concrete deck, anchorage studs, welds, joint failures, concrete placement, consolidation, weep holes, pouring sequence, voids, form placement</i>			18. Distribution Statement <i>No restrictions. This document is available to the public through the National Technical Information Service, Springfield, Virginia 22161.</i>		
19. Security Classif. (of this report) <i>Unclassified</i>		20. Security Classif. (of this page) <i>Unclassified</i>		21. No. of Pages <i>48</i>	22. Price

EVALUATION OF FAILURE IN BRIDGE EXPANSION JOINT RAILS

by

V. Dolan and K.H. Frank

Research Report Number 1309-1F

Research Project 0-1309

EVALUATION OF FAILURE IN BRIDGE EXPANSION JOINT RAILS

conducted for the

Texas Department of Transportation

in cooperation with the

**U.S. Department of Transportation
Federal Highway Administration**

by the

**CENTER FOR TRANSPORTATION RESEARCH
BUREAU OF ENGINEERING RESEARCH
THE UNIVERSITY OF TEXAS AT AUSTIN**

OCTOBER 1994

IMPLEMENTATION

Strip seal expansion joint systems are composed of two structural parts; the rail and the concrete deck. Failures of expansion joints can be due to failures of either one of these components or a combination of both. The results of this investigation have indicated that the failure of the expansion joints in McAllen was due to a failure in the concrete part of the system. This failure resulted in unintended loads on the anchorage studs leading to the observed joint failures.

Testing of the rail sections, studs and welds showed no predisposition of the rails to failure. The steel makeup and stud welding appeared to be of uniform consistency and acceptable quality. Although failure of the expansion joints expresses itself in the rails and studs, this is a secondary effect which is induced by problems with the concrete placement.

Failure of the concrete was due to the lack of complete concrete consolidation under the rail. Incomplete consolidation of the concrete is attributed to several factors including: lack of weep holes, form placement and pouring sequence. Weep holes in the top flange of the rail are necessary to allow for excess air and bleed water to escape from underneath the rail. The holes also act as a method of quality assurance. The presence of concrete in these holes after concrete placement indicates the presence of concrete under the rail. Correct form placement at the ends of the slab is necessary so that concrete is present under the lower lip of the vertical flange. Pouring sequence of the slab is also an important factor to consider when using strip seal expansion joints, especially on sloped bridges. The pouring sequence used on the McAllen bridges was typically downhill. By starting concrete placement at the highest point and proceeding to the lowest there is a possibility that the plastic concrete will flow downhill. This flow will pull concrete away from the inside of the rail and result in detrimental voids. Consideration to the concrete flow problem should be given when deciding on concrete pouring sequences and consolidation practices. Congestion of the slab reinforcement at the rail, aggravates proper placement of the concrete. The spacing between the bars should follow the standard practices regarding reinforcing steel spacing.

Prepared in cooperation with the Texas Department of Transportation and
the U.S. Department of Transportation, Federal Highway Administration

The contents of this report reflect the views of the authors, who are responsible for the facts and the accuracy of the data presented herein. The contents do not necessarily reflect the views or policies of the Federal Highway Administration or the Texas Department of Transportation. This report does not constitute a standard, specification, or regulation.

There was no invention or discovery conceived or first actually reduced to practice in the course of or under this contract, including any art, method, process, machine, manufacture, design or composition of matter, or any new useful improvement thereof, or any variety of plant, which is or may be patentable under the patent laws of the United States of America or any foreign country.

NOT INTENDED FOR CONSTRUCTION,
BIDDING, OR PERMIT PURPOSES

Karl H. Frank, Texas P.E. #48953

Research Supervisor

TABLE OF CONTENTS

INTRODUCTION..... 1

FIELD OBSERVATIONS 2

 Ramp 4, Pier 25 2

 Ramp 4, Pier 22 2

 Ramp 3, Pier 22 2

 Ramp 3, Pier 20 3

 Ramp 2, Piers 20 and 22..... 3

 Route 79 and MacMill Road Bridge Rails..... 3

 Summary of Field Observations..... 4

RAIL AND STUD SAMPLE TESTING 4

 Chemical Analysis 4

 Weld Structure 5

 Hardness Testing..... 5

ROADWAY SECTION..... 5

SUMMARY OF FINDINGS 7

LIST OF FIGURES

Figure 1	Typical strip seal expansion joint with seal and anchorages	1
Figure 2	Arrangement of expansion joints at steel bent caps	1
Figure 3	Fracture area along rail.....	8
Figure 4	Left side of rail shows several bent over studs without failure.....	9
Figure 5	Lack of complete concrete consolidation is seen on the right rail when compared to the left rail. Also note the missing studs on the right.....	10
Figure 6	Scarring of the rail due to excessive movement.....	11
Figure 7	Stud and rail locations showing fracture and missing stud section.....	11
Figure 8	Fractured stud with attached reinforcing steel	12
Figure 9	Close placement of the reinforcing steel to the rail.....	12
Figure 10	Depth of hole along top rail of joint.....	13
Figure 11	Voids along the bottom of the rail.....	14
Figure 12	Void is to a depth of 7/16-in.	14
Figure 13	Voids along the end of slab surface.....	15
Figure 14	Cracking of the concrete along the rail	16
Figure 15	Rail cross-section	17
Figure 16	Weld Sample MW1	17
Figure 17	Weld Sample MW2.....	18
Figure 18	Weld Sample MW3	18
Figure 19	Weld Sample MW4	19
Figure 20	Weld Sample GW1.....	19
Figure 21	Weld Sample GW2.....	20
Figure 22	Weld Sample GW3.....	20
Figure 23	Weld Sample GW4.....	21
Figure 24	Weld Sample IW1	21
Figure 25	Sample McAllen Weld #1	22
Figure 26	Sample McAllen Weld #2	22
Figure 27	Sample McAllen Weld #3	23
Figure 28	Sample McAllen Weld #4	23
Figure 29	Sample Georgetown Weld #1	24
Figure 30	Sample Georgetown Weld #2	24
Figure 31	Sample Georgetown Weld #3	25
Figure 32	Sample Georgetown Weld #4	25
Figure 33	Sample Illinois Weld #1	26
Figure 34	Front view of roadway section	27
Figure 35	End view of roadway section	27
Figure 36	Approximately 2-in. void along end 2 and note reinforcing bar location (round dot).....	28
Figure 37	Void at end 3 also vertical reinforcing bar	28
Figure 38	Locations of cuts to be made in rail	29
Figure 39	Roadway section in milling machine	29
Figure 40	Roadway section in milling machine	30
Figure 41	Rail section removed note lack of rail along roadway (raked) surface.....	30
Figure 42	Edge view of roadway section after rail is removed.....	31
Figure 43	Edge view of roadway section after rail is removed.....	31
Figure 44	Concrete surface was pasty after removal of the rail section.....	32
Figure 45	The oval at the left near 2-in. shows a void underneath the rail	32
Figure 46	Studs were located at 7-in. and 17-in.	33
Figure 47	Small void at the base of the stud.....	33
Figure 48	Small void at the base of the stud.....	34
Figure 49	Excavation of stud in roadway section.....	34

Figure 50	Excavation of study in roadway section	35
Figure 51	Failure surface of excavated stud	35
Figure 52	Failure surface of excavated stud	36
Figure 53	Failure surface of excavated stud	36
Figure 54	Orientation of crack in stud, rail and loading	37
Figure 55	Cross-section of roadway section after removal of stud	37
Figure 56	Fracture surface of second removed stud.....	38

SUMMARY

Strip seal expansion joint systems are composed of two structural parts; the rail and the concrete deck. Failures of expansion joints can be due to failures of either one of these components or a combination of both. The results of this investigation have indicated that the failure of the expansion joints in McAllen was due to a failure in the concrete part of the system. This failure resulted in unintended loads on the anchorage studs leading to the observed joint failures.

Testing of the rail sections, studs and welds showed no predisposition of the rails to failure. The steel makeup and stud welding appeared to be of uniform consistency and acceptable quality. Although failure of the expansion joints expresses itself in the rails and studs, this is a secondary effect which is induced by problems with the concrete placement.

Failure of the concrete was due to the lack of complete concrete consolidation under the rail. Incomplete consolidation of the concrete is attributed to several factors including: lack of weep holes, form placement and pouring sequence. Weep holes in the top flange of the rail are necessary to allow for excess air and bleed water to escape from underneath the rail. The holes also act as a method of quality assurance. The presence of concrete in these holes after concrete placement indicates the presence of concrete under the rail. Correct form placement at the ends of the slab is necessary so that concrete is present under the lower lip of the vertical flange. Pouring sequence of the slab is also an important factor to consider when using strip seal expansion joints, especially on sloped bridges. The pouring sequence used on the McAllen bridges was typically downhill. By starting concrete placement at the highest point and proceeding to the lowest there is a possibility that the plastic concrete will flow downhill. This flow will pull concrete away from the inside of the rail and result in detrimental voids. Consideration to the concrete flow problem should be given when deciding on concrete pouring sequences and consolidation practices. Congestion of the slab reinforcement at the rail, aggravates proper placement of the concrete. The spacing between the bars should follow the standard practices regarding reinforcing steel spacing.

Introduction

This report summarizes the investigation into the cause of failures of strip seal expansion joints at the US 83 and US 281 interchange at McAllen, Texas. The investigation was made at the request of the Texas Department of Transportation. The interchange of US 83 and US 281 at McAllen, Texas, opened in December of 1993, is composed of four unidirectional ramps (1, 2, 3, 4). Each of the ramps uses a mix of simple span AASHTO girders and continuous steel girders. The supporting substructure includes both concrete and steel bent cap systems with concrete piers. Concrete systems are inverted tee bents, hammerhead or tee piers and concrete beam straddle bents. Decking for all of these structures is 8-inch reinforced concrete with a design strength of 24.8 MPa (3600 psi). Concrete mixes for the deck were standard TxDOT S class mixes with a maximum aggregate size of 38 mm (1-1/2 inches). All ramps have vertical grade and most are in horizontal curves with super elevation.

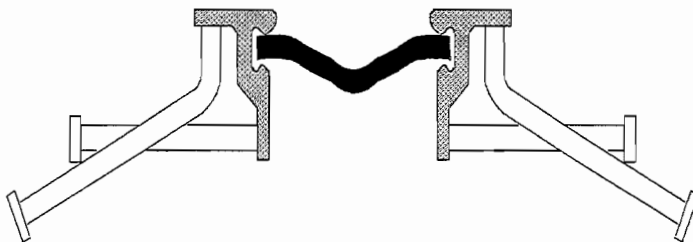

Figure 1 Typical strip seal expansion joint with seal and anchorages

Expansion joints for the interchange are elastomeric strip seals. Joints are made up of rails located on each side of the expansion area. A rubber seal is attached to both rails to prevent drainage at the joint. The rails are made of steel and are held in place with 152 mm (6-in.) by 13 mm (1/2-in.) diameter studs cast in the concrete. Figure 1 shows a cross section of rail and strip seal. Studs are alternately attached to the top and side of the rail at 305 mm (12 inches) on center. Spacing of the joints was

typically every three spans in the concrete section (≈ 91.5 m (300 feet) between joints) and at ends of each continuous steel girder unit. The arrangement of expansion joints varied depending on the substructure type. For inverted tee bents only one expansion joint unit was used. At steel box girder bents two units were used. This arrangement is shown in Figure 2. The supplier of joints on this interchange was Watson-Bowman.

After being in service for less than six months, the expansion joint units began to show signs of distress. Distress in the joints was usually in the form of the rail moving under vehicle traffic. Movement of the joint was found by either listening for a loud “clanking” noise as traffic passed over the joint, or watching for joint movement due to passing traffic. Once all of the distressed joints were identified, the contractor removed a 305 mm (1-foot) section of the concrete around the joint with jackhammers. The exposed joints were then removed and replaced with a new joint. The new joint conformed with new TxDOT standards of 16 mm (5/8-in.) studs and 13 mm (1/2-in.) weep holes drilled along the top of the rail.

At the invitation of the Pharr District office, a trip was made to McAllen to determine the cause of the joint failures. During this trip the contractor was proceeding with the joint removal and reinstallation process,

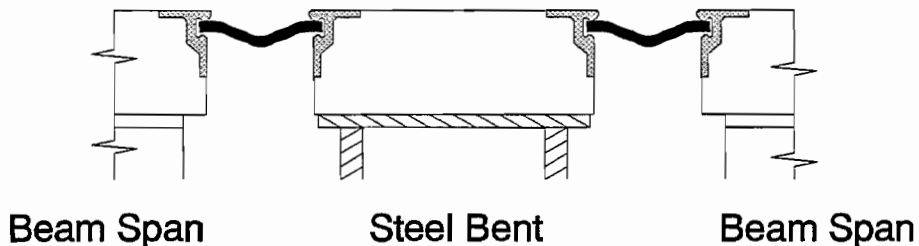

Figure 2 Arrangement of expansion joints at steel bent caps

several failed joints were inspected and observations were made. The inspected joints had either been removed from the bridge slab or were viewed in place, either with the concrete in place or removed.

Field Observations

Ramp 4, Pier 25

The first failed joint inspected was an abutment at Ramp 4, Pier 25. The joint at Pier 25 was completely removed from the slab at the time of inspection. Inspection of the rail revealed fractures of the studs along the rail. Stud failures were only present on the abutment side of the joint unit. The abutment side of the joint was located on the downstream side of the traffic flow and was on the uphill end of the approach slab. Stud failures had only occurred in the horizontal studs. Comparison of the failed studs revealed that all the stud failures occurred at the weld region area where the stud is welded to the rail, Figure 3. The remaining studs along the rail were bent over using a hammer to test soundness of their welds, Figure 4. Bending over the remaining studs along the rail resulted in no additional stud failures. Failed stud locations along the rail exhibited peening at the fracture faces. This peening indicated movement between the rail section and the stud after fracture. Inspection of the abutment side joint rail showed visual evidence of a lack of concrete consolidation in those areas. Lack of consolidation was determined by the brownish color of the rail on the surface adjacent to the slab when compared to whitish color of the rail, Figure 5, on the upstream side of the joint and on the downstream rail in areas without stud failures. Both sides of the joint showed no evidence of anchor stud failures where the whitish color existed. Weep holes or vent holes, drilled in the top surface of the rail to vent any trapped air or water under the rail at the time of concrete placement, required by the recently instituted state standard were not present. Several sections of the rail at this pier were removed for further analysis. Failed studs were also removed from the joint rubble for further study.

Ramp 4, Pier 22

The expansion joint at Bent 22, Ramp 4 was inspected next. This joint had been removed from the deck. This joint is the next joint opposite the traffic flow direction from Bent 25 and is at a higher elevation. Failures of this joint occurred along the downstream rail. The downstream rail showed fracture of several studs, both vertical and horizontal. Lack of concrete consolidation was evident at stud failure locations. The face of the rail had brown coloration in those areas with stud failures. Remaining studs along the rail, which had not failed, were bent over to test the soundness of the welds, no failures occurred. Pounding or scarring of the horizontal flange of the rail was also present (Figure 6), indicating excessive movement of the rail after stud fracture, peening at the failed stud locations was evident. No failed studs were found in the upstream rail.

Ramp 3, Pier 22

Inspection of the expansion joint at Ramp 3, Pier 22, was conducted while the contractor was removing the concrete around the joint. This pier was an abutment pier. Stud failures were found along the downstream or abutment side of the joint. Failures had occurred in three horizontal and one vertical stud. As with the previous joints, failures occurred in areas of the joint, with brown colored regions. There were some areas of the rail with brown patches and no stud failures. Due to the low number of failures, it was felt that the observed failed studs were just the initial failures. Unfortunately, the contractor had not completed removal of the joint by the time of departure. The remaining studs could not be tested by bending to determine if they contained fatigue cracks.

The joint did have details which provided further insight into the stud fracture problem. The first was on the abutment side where one of the fractured studs had an approximately 19 mm (3/4-in.) piece missing in the fracture zone (Figure 7). This stud was welded to a reinforcing bar to hold the joint in place during casting of the deck. The welded portion of the stud was intact but was separated from the stud section attached to the rail by 19 mm (3/4-in). Inspection of the two fracture surfaces indicated that they were not the same surface. Due

to the contractors demolition methods, the missing piece was not recovered. On the upstream side of the rail another interesting stud fracture had occurred. This fracture, the only stud fracture on the upstream side, had occurred in a horizontal stud. For this fracture the stud was recovered intact with reinforcing steel welded to it, Figure 8.

Since the inspection of the joint occurred while the contractor was in the process of removing the concrete it was possible to view the joint with the reinforcing steel in-place. The presence of the reinforcing steel at this joint illustrated correct placement of the reinforcing steel was necessary for proper behavior of the joint to occur. Figure 9 shows placement of reinforcing steel too close to the rail. Steel placement in this manner prevents the flow of medium-sized aggregate ($d > 19 \text{ mm}$ ($3/4 \text{ in.}$)) under the rail. Complete placement of the concrete cannot occur when this area is blocked and detrimental voids will form.

Ramp 3, Pier 20

Pier 20 on Ramp 3 was a box steel bent with expansion joints (See Figure 2). The downstream joint of the two present at this bent was examined in place. The examination showed small cracks in the concrete deck along the lip of the downstream side rail. Using a screwdriver and pry bar to lift the rail small pieces of loose concrete were removed. Surface concrete near the rail edge was not very strong and could be described as "Punky." After removal of this concrete a tape measure was inserted into the resulting hole as shown in Figure 10 to a depth of 41 mm (1-5/8-in.) The downstream rail was easily moved using a pry indicating that it was very loose.

Also, while at this joint, the gland between the two rails was removed. By removing the gland voids along the bottom of the rail were revealed. Figures 11 and 12 show one of these voids with a depth of 11 mm (7/16 in.) It was also noted that the finish of the concrete along this face of the slab did not appear to be flush with the edge of the rail. The surface appeared to have numerous voids along the edge of the form (Figure 13). The inconsistent finish of the slab along this edge appears to be an indicator of consolidation problems at the joint. The joint at Pier 20 was both uphill and upstream of Pier 22. The joint at Pier 20 was schedule for replacement.

Ramp 2, Piers 20 and 22

Ramp 2 provided the opportunity to inspect 2 severely distressed joints. Unfortunately, Ramp 2 was open to traffic and the inspection could only be completed from the shoulder. The first joint inspected on Ramp 2 was at Pier 22. The joint at Pier 22 showed small movement and produced an audible clanking noise under traffic. No cracking of the concrete at Pier 22 was apparent when viewed from the shoulder. The joint at Pier 20 showed severe signs of distress with large visible movements under traffic. The joint also had three cracks in the concrete running transversely across the roadway on the downstream side of the joint (Figure 14). Each of these cracks was four to six feet long. A section of the roadway under the right-hand wheel line at Pier 22 was marked for removal. The purpose of removing this section intact was to provide a specimen which could be dissected and the placement of concrete under the rail section observed. This marked section when removed from the roadway would become the "Roadway Section" studied later in this report.

Route 79 and MacMill Road Bridge Rails

A field trip to the Georgetown field office of TxDOT was made to examine another set of rails which had failed in service. The office had several rails from two bridges in their district which had failed shortly after installation (six months) and were replaced. These bridges were the Route 79 and MacMill Road Bridges at I-35 near Round Rock, Texas. Unfortunately, the rails had been removed almost two years before the time of inspection and oxidation of the surfaces had occurred.

Even with the oxidation of the rail surfaces, several observations were made. Joints on the Round Rock bridges were used in conjunction with asphaltic overlays. The rails used were made of studs attached to an angle section with a grooved channel section for the seal welded to the angle section (Figure 15). Even with

oxidation due to the extended exposure, the rails showed the patches of white along them exhibited in the trip to McAllen. These rails also displayed extensive scarring due to movement of the joint. Over 30.5 m (100 feet) of rail was inspected with only seven studs found. Of these seven studs, five were completely intact on one rail. These five studs on one rail were bent over without failure. The other two studs were only portions of studs and failed at the weld when bent over. Weep holes were located along the vertical face of the angle making up the joint.

While inspection of these joints revealed almost complete loss of studs and the presence of white areas along the joint, the fact that an overlay was present must be considered. This overlay would mask movement of the joint until complete failure of the joint occurred. Complete failure is due to initial loss of studs in unconsolidated areas and subsequent overloading of the remaining studs. Several sections of rail were removed for further investigation.

Summary of Field Observations

1. The locations of stud failures was associated with areas of voids between the rail and concrete bridge deck. These voids were evident by the brown colored areas along where stud failures had occurred.
2. Bending over of the studs adjacent to areas where studs had failed did not result in the fracture of the studs in the McAllen interchange. This simple test indicated that the welds were of reasonable quality and the studs did not contain significant fatigue cracks.
3. The lack of consolidation of the concrete was aggravated by the congestion of reinforcing steel at the rail. Voids in the concrete were visually observable at the vertical surface, at the end of the slab, and under the rail.
4. The rail which contained the fractured studs and the voids in the concrete in most cases was at the upper end of the slab. Poor consolidation of the concrete was probably aggravated by the tendency of the plastic concrete to flow away from the rail.

Rail and Stud Sample Testing

Tests were performed on the recovered section of rails at Bent 25, Ramp 4, in McAllen and from the Georgetown District to determine the properties of joint materials and evaluate the fabrication techniques used. To further widen the study, a section of rail from another research project was also evaluated. This rail section had been subjected to static load testing in the laboratory and performed acceptably.

Chemical Analysis

The first test run was a spectrographic chemical analysis of the rail and stud metals from each of the rails. The purpose of this test was to determine if the chemical composition of the component materials predisposed the rails to either fatigue or weldability problems. Results of this analysis are listed in Table 1.

Carbon contents of less than 0.2% were found for all specimens. Chemical analysis showed slightly higher than normal percentages of Manganese (0.88%), Chromium (0.50%) and Vanadium (0.027%) from the McAllen rail samples. While higher than the other rails, these values are not untypical for electric furnace steel with the exception of the high chromium content. The rail steel all met the requirements of ASTM A36 with copper specified for enhanced corrosion protection. For the stud specimens, the higher than expected presence of aluminum (0.068%) in the McAllen stud was all that was noted. These specific values are higher than average but did not deviate far enough to cause significant changes in the behavioral or welding properties of the rail or stud metals with the exception of the high chromium in the McAllen rail. The additional chromium is equivalent to an increase in carbon of approximately 0.10%.

Weld Structure

Sections were then cut through the rail welds for etching. Each specimen was cut, ground, polished and then etched with a Ferric Chloride solution. This solution made the macrostructure of the weld clearly discernible. Figures 16 through 24 show the etched specimens. Etching showed the welds to be of consistent quality and to be free of any harmful flaws. The welds indicated that stud guns used for placing these studs were properly calibrated and operated consistently.

Hardness Testing

After etching, each of the sections was subjected to hardness testing. Hardness testing was used to see if the welding process caused a significant change in the rail or stud strength. All these tests were performed using the Rockwell C scale. The decision to report the Rockwell C scale (R_c) over the Rockwell B scale (R_b) for specimens was based on testing using both scales. Testing using the R_b scale worked well for the base metal but was inconclusive for the weld metal and heat affected zone due to the high hardness of the material. Use of the R_c scale worked well for the weld metal and heat-affected zones and some readings for the base metal were below the recommended range for the C scale. Extrapolations required for the R_c scale were not as large as those needed to use the R_b scale, thus the R_c scale was chosen. Mappings of the hardness testing and results are shown in Figures 25-33. The numbered location is shown in the figure with the hardness reading given in the table directly below the figure. The abbreviations listed for each of the areas are:

BM = Rail Base Metal WM = Weld Metal
ST = Stud Base Metal HAZ = Heat Affected Zone

The average results of hardness tests on the samples are shown in Table 2. These results show some hardening of the base metal in the heat affected zone but not enough to cause a brittle weld. The ductility of the welds was confirmed by the bend over tests performed in the field.

Location	Rockwell C	Estimated Tensile Strength*	
	Average	Mpa	(ksi)
Base Metal	8.2	604	87.6
Weld Metal	26.4	826	119.8
Stud Material	6.1	587	85.1
Heat Affected Zone	26.7	896	130.0

*From "The Procedure Handbook of Arc Welding," 12th Edition, The Lincoln Electric Company, Cleveland, OH, June 1973.

Roadway Section

During the observation of the joint removal and reinstallation process in McAllen a section of the roadway at Pier 22 along Ramp 2 was marked for careful removal. Careful removal meant that the rail and surrounding concrete were to be removed intact. On June 2, 1994, the rail section was removed by the repair contractor under the supervision of TxDOT. The section was saw cut from the end of the slab. The removed block was then shipped to the Ferguson Structural Engineering Laboratory at The University of Texas at Austin. The purpose of removing this section intact was to provide an opportunity to inspect the state of concrete under the rail. From the observations made at McAllen, there appeared to be a direct correlation between the lack of consolidated concrete under the rail and stud failure.

The specimen that arrived at the Ferguson Lab is shown in Figures 34 and 35 (front and end view). Inspection of the block immediately showed a lack of complete concrete consolidation. This lack of concrete consolidation was illustrated by the presence of voids at both ends of the specimen (Faces 2 and 3) as well as voids along the lower lip of the rail. Figures 36 and 37 identify these voids and quantify their depth. Another feature of the block, which was symptomatic of the failed joints in McAllen was the close proximity of the reinforcing steel to the rail. Figure 37 shows a bar along Side 3 which is touching the rail and Figure 36 illustrates the close proximity of the transverse bar to the rail lip. This close arrangement of the bar and rail was also present at Ramp 3, Pier 22. Presence of these bars close to the rail causes the rail and reinforcing bar to act as a filter. Filtering action by the rail and reinforcing bar catches large aggregate and prevents it from flowing underneath the rail. The "caught" aggregate increases the filtering and impedes the flow of smaller aggregate and cement paste under the rail which ultimately leads to voids. Once these preliminary observations were complete a portion of the rail was removed, from the section.

Complete removal of the rail was not necessary to check for proper concrete consolidation. Instead, the corner section of the rail was removed. The corner section of the rail was of prime interest. Field observations had shown a correlation between lack of concrete in this area and stud failure. In order to remove the corner section of the rail two cuts were made in the rail section. The location of these cuts are shown in Figure 38. By choosing these two lines for cutting the most rail material could be removed without cutting at a stud weld. To perform these cuts the block was moved to a horizontal milling machine and anchored in place. Cuts were then made in the rail using a 102 mm (4-in.) by 6.4 mm (1/4-in.) carbide tipped cutting blade. Figures 39 and 40 show the block in the mill during the cutting of the second side of the rail. An Accu-Lube mist cooling system was used to minimize any contamination of the specimen due to cooling of the cutting blade. Upon completion of the second cut it was realized that a stud connected to the top lip of the rail had failed. This allowed for a more complete removal of the rail as illustrated in Figure 41 with one lip of the rail present.

With removal of the rail complete, it was readily apparent that complete consolidation of the concrete along the corner of the rail had not occurred. Figures 42 and 43 show views of the section looking down the corner of the block section. It is apparent in the figures (42 & 43) that in areas, the concrete did flow into the corner of rail as indicated by the highest or hump areas. The now exposed concrete section also exhibited a pasty or crusty white coating on the exposed surface shown in Figure 44. This pasty coating indicated the presence of bleed water in this area during curing. By allowing bleed water to collect, the strength of the concrete was further reduced in this critical area. The section also showed the presence of voids along the underside of the rail. Figure 45 shows the presence of one such void.

Inspection of the removed rail exhibited the same pattern of brown coloration seen in the field observations. The coloration along the rail was compared to the humps and voids along the block edge, a direct correlation was found. This correlation is that brown patches along the rail indicate a lack of concrete in these areas. This is in agreement with the observations of brown areas and stud failures made during the trip to McAllen. Upon completion of the observation of the rail, the stud at 7" in Figure 46 was excavated.

Before excavation of the stud, the excess rail on both sides of the stud was removed from the block. It was also noted that the area near the base of the stud had a void. This void is shown in Figures 47 and 48. The stud was excavated as shown in Figures 49 and 50. Excavation revealed that there was a small open area around the base of the stud. After completely exposing the stud it was removed from the block by cutting the reinforcing bar shown in Figure 50. The removed stud was then placed in a vise and the stud was bent over using a hammer. This bending over of the stud was done to test the soundness of the stud weld. The stud failed in this test and revealed an interesting fracture surface. By examining the fracture surface, Figures 51, 52 and, 53, it is apparent that the smooth semicircular region is a fatigue crack propagating through the stud. This type of crack would ultimately lead to failure of the stud. Figure 54 shows the orientation of the stud, fatigue crack, rail and roadway.

The second stud was then excavated from the section. It was assumed that this stud was already fractured at the time of the section's removal from the bridge deck. The location of the stud is indicated by the hole at the 431 mm (17") point in Figure 46. Excavation of this stud did not show any signs of improper consolidation along the stud section remaining in the block, Figure 55. This stud was a bent stud, but fracture occurred in a

region tangent to the bend. The embedded section of the stud was removed from the specimen and the fracture surface examined. Figure 56 shows the fracture surface of the embedded stud. The failure surface has a slight crowning with the peak being in a straight line across the middle of the section. This fracture surface also appears to be a fatigue induced failure, due to cyclical bending of the section.

An evaluation of the insitu strength of the slab concrete was performed on the roadway section using a Schmidt or rebound hammer. Specifically a DIGISchmidt hammer by PROCEQ was used for this testing. Prior to testing the performance of the instrument was checked using a testing anvil and was found to be satisfactory. Three separate tests were performed on the specimen each consisting of eight blows. Statistical analysis of each set of eight blows was performed by the instrument to increase the precision of the reading. The resulting reading of each test was then used by the instrument to calculate the concrete compressive strength. Results of these tests are shown below:

Schmidt Hammer Reading	Estimated Concrete Compressive Strength	
	Mpa	(psi)
41.0	28.7	4160
44.0	32.4	4700
42.3	30.3	4390

These results show an average concrete compressive strength of 30.3 Mpa (4400 psi.) This test may not be as accurate as a core test, but it is sufficient to show that there was not a localized reduction of concrete strength in the roadway section.

Summary of Findings

Strip seal expansion joint systems are composed of two structural parts; the rail and the concrete deck. Failures of expansion joints can be due to failures of either one of these components or a combination of both. The results of this investigation have indicated that the failure of the expansion joints in McAllen was due to a failure in the concrete part of the system. This failure resulted in unintended loads on the anchorage studs leading to the observed joint failures.

Testing of the rail sections, studs and welds showed no predisposition of the rails to failure. The steel makeup and stud welding appeared to be of uniform consistency and acceptable quality. Although failure of the expansion joints expresses itself in the rails and studs, this is a secondary effect which is induced by problems with the concrete placement.

Failure of the concrete part of the system was due to the lack of complete concrete consolidation under the rail. Incomplete consolidation of the concrete is attributed to several factors including: lack of weep holes, form placement and pouring sequence. Weep holes in the top flange of the rail are necessary to allow for excess air and bleed water to escape from underneath the rail. The holes also act as a method of quality assurance. The presence of concrete in these holes after concrete placement indicates the presence of concrete under the rail. Correct form placement at the ends of the slab is necessary so that concrete is present under the lower lip of the vertical flange. Pouring sequence of the slab is also an important factor to consider when using strip seal expansion joints, especially on sloped bridges. The pouring sequence used on the McAllen bridges was typically downhill. By starting concrete placement at the highest point and proceeding to the lowest there is a possibility that the plastic concrete will flow downhill. This flow will pull concrete away from the inside of the rail and result in detrimental voids. Consideration to the concrete flow problem should be given when deciding on concrete pouring sequences and consolidation practices. Congestion of the slab reinforcement at the rail, aggravates proper placement of the concrete. The spacing between the bars should follow the standard practices regarding reinforcing steel spacing.



Figure 3 Fracture area along rail



Figure 4 Left side of rail shows several bent over studs without failure

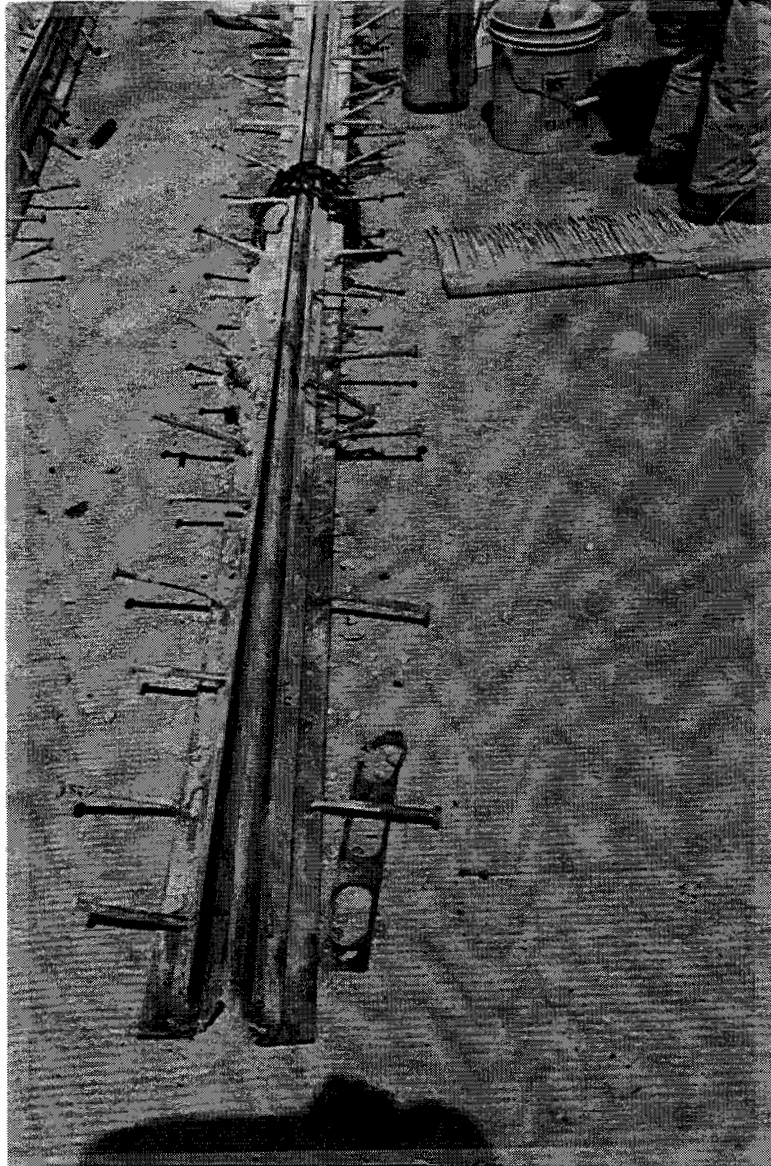

Figure 5 Lack of complete concrete consolidation is seen on the right rail when compared to the left rail. Also note the missing studs on the right.

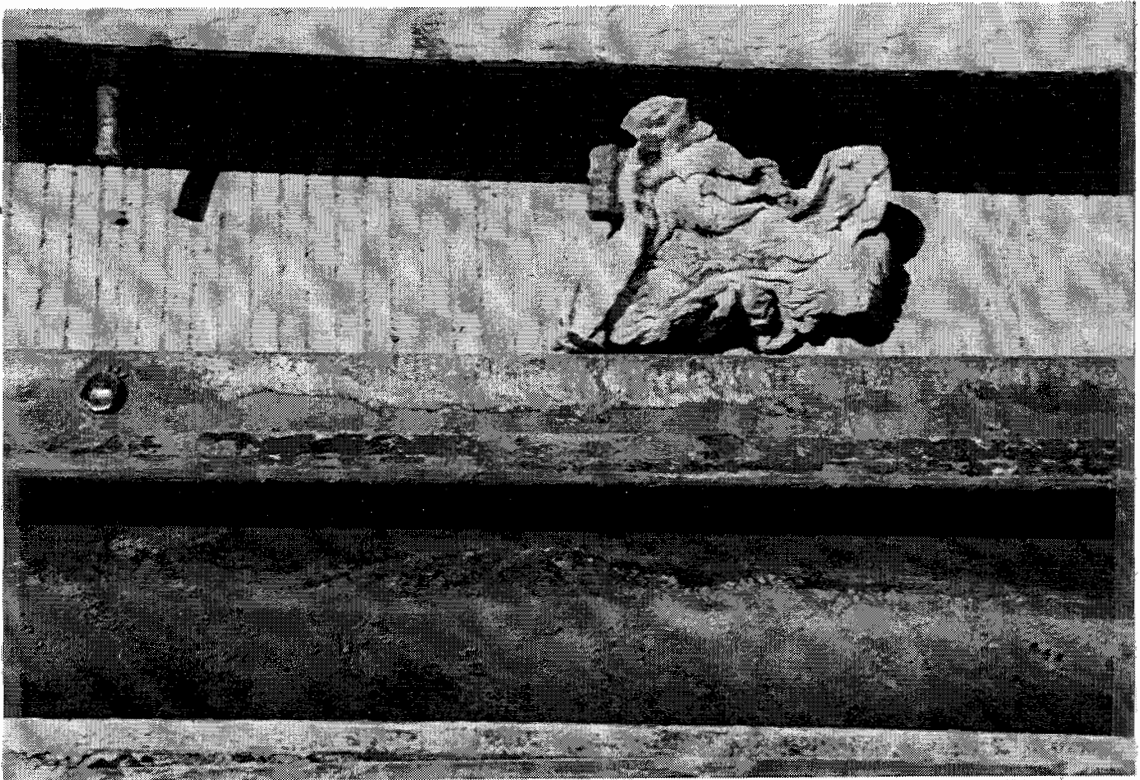

Figure 6 Scarring of the rail due to excessive movement

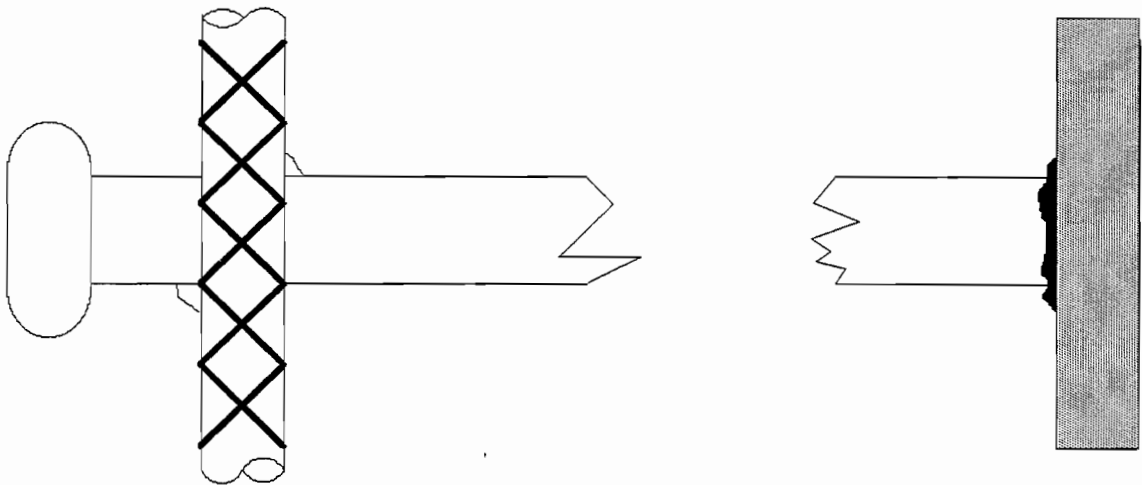

Figure 7 Stud and rail locations showing fracture and missing stud section

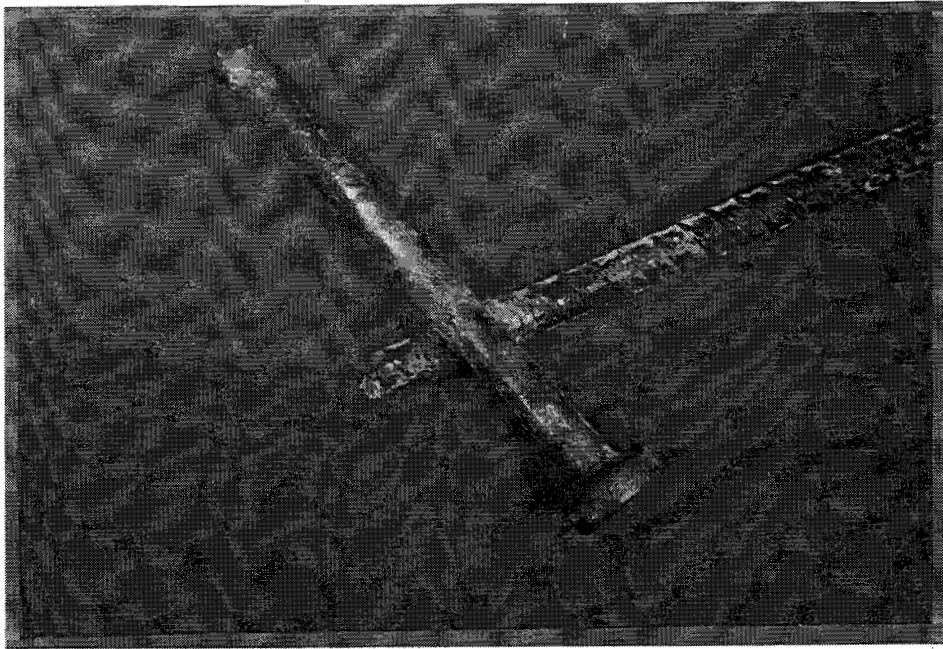

Figure 8 Fractured stud with attached reinforcing steel



Figure 9 Close placement of the reinforcing steel to the rail



Figure 10 Depth of hole along top rail of joint

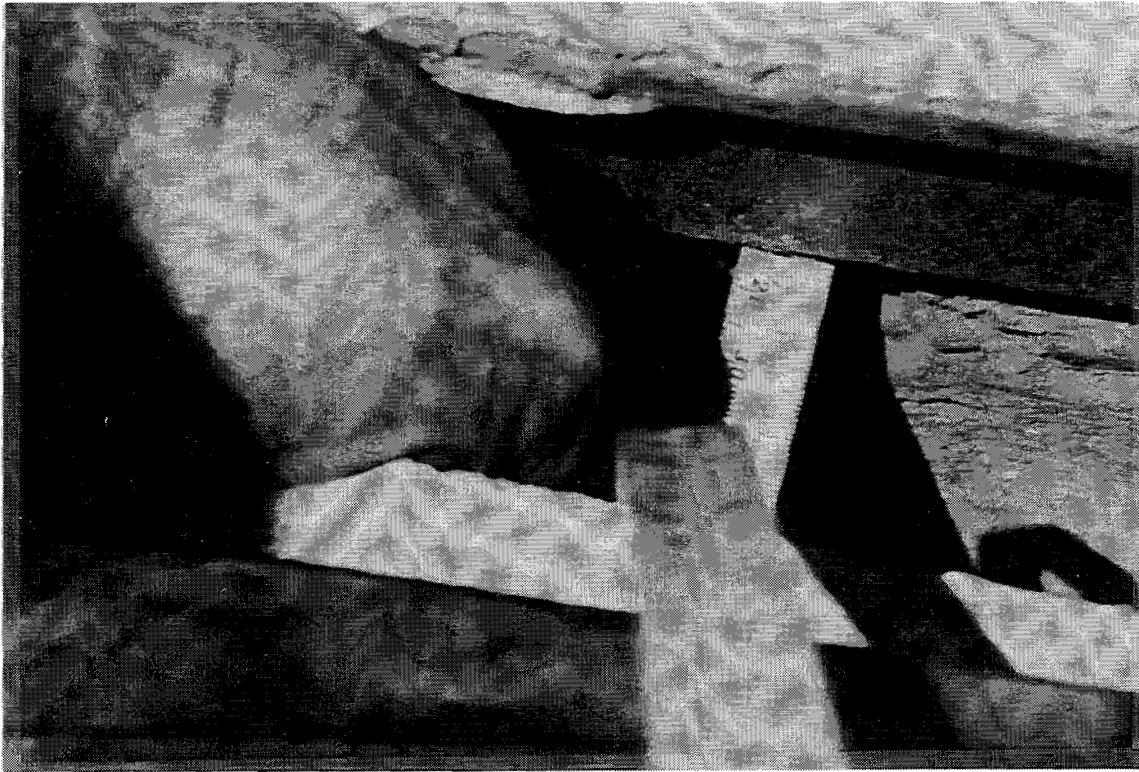

Figure 11 Voids along the bottom of the rail

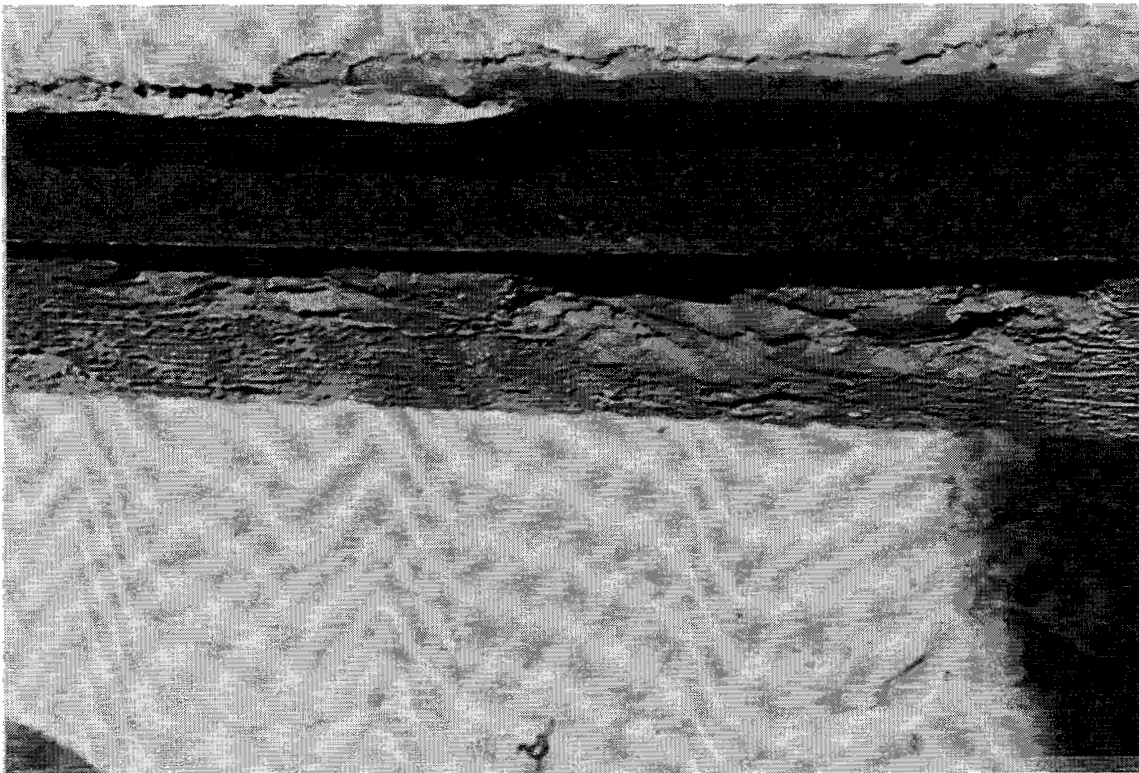

Figure 12 Void is to a depth of 7/16-in.

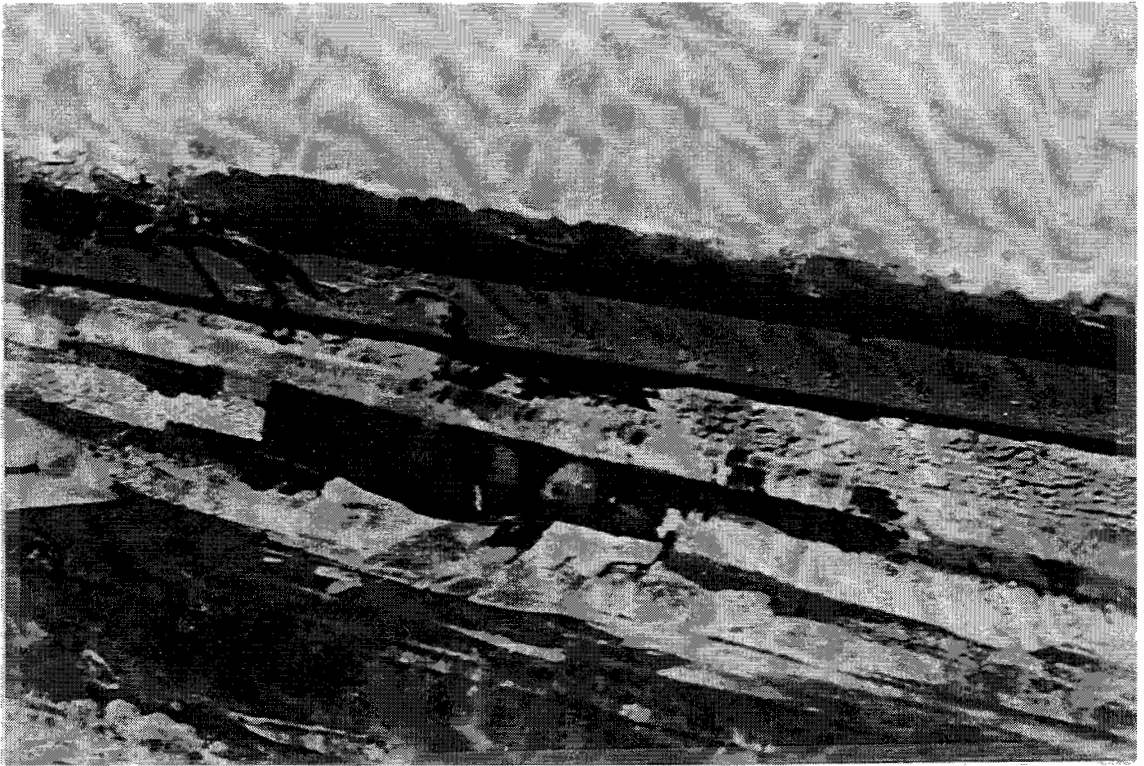

Figure 13 Voids along the end of slab surface

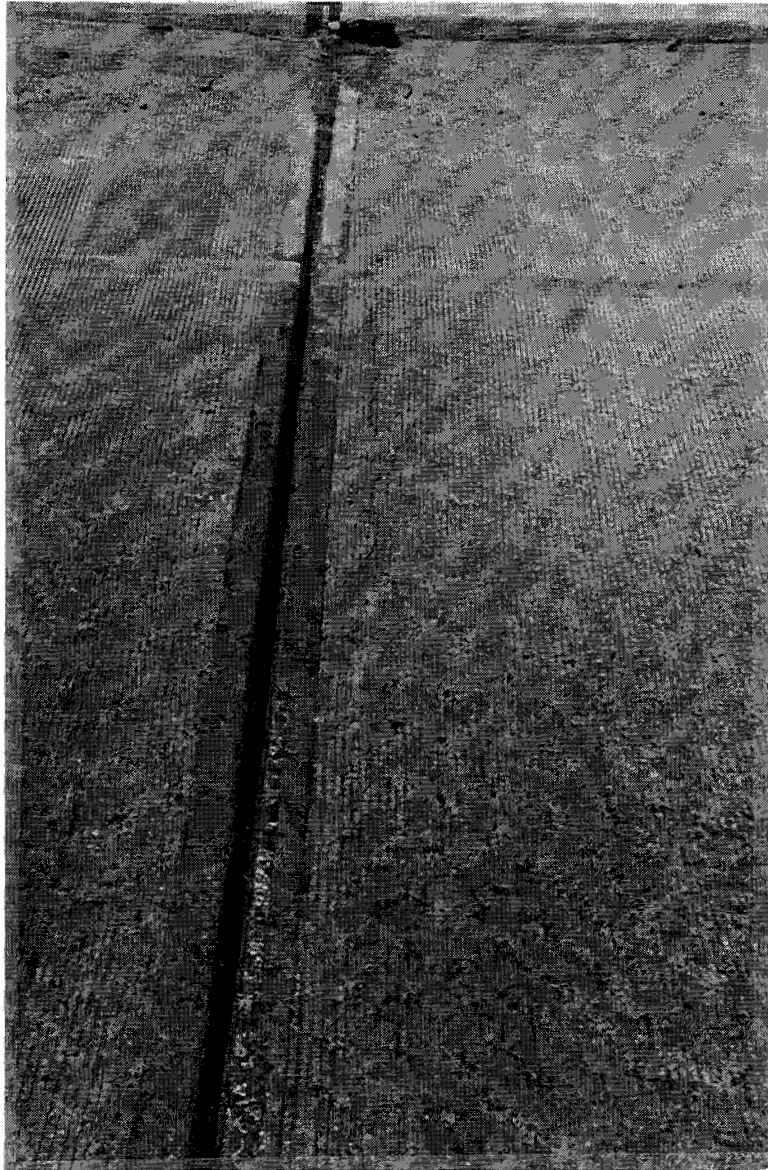

Figure 14 Cracking of the concrete along the rail

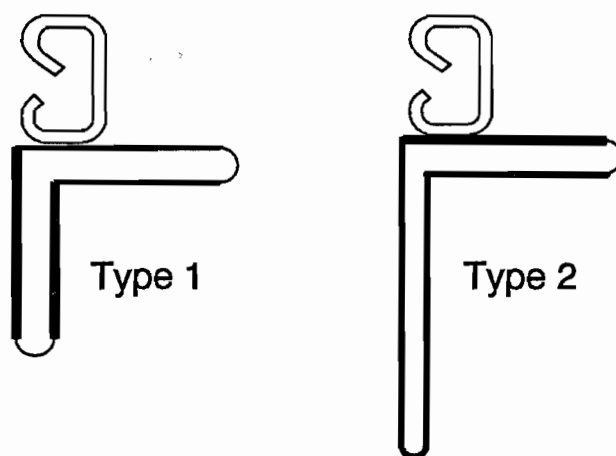

Figure 15 Rail cross-section

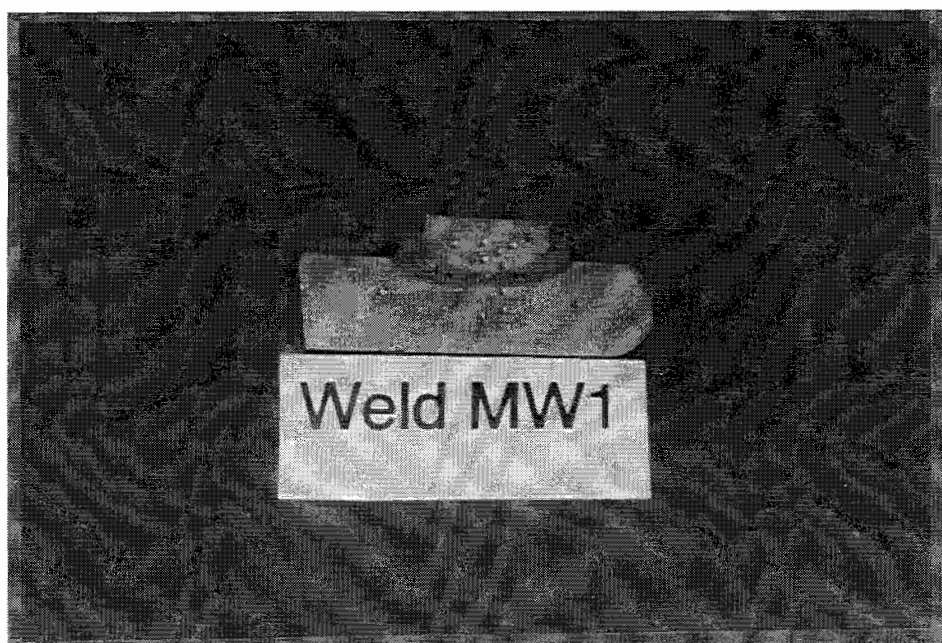

Figure 16 Weld Sample MW1

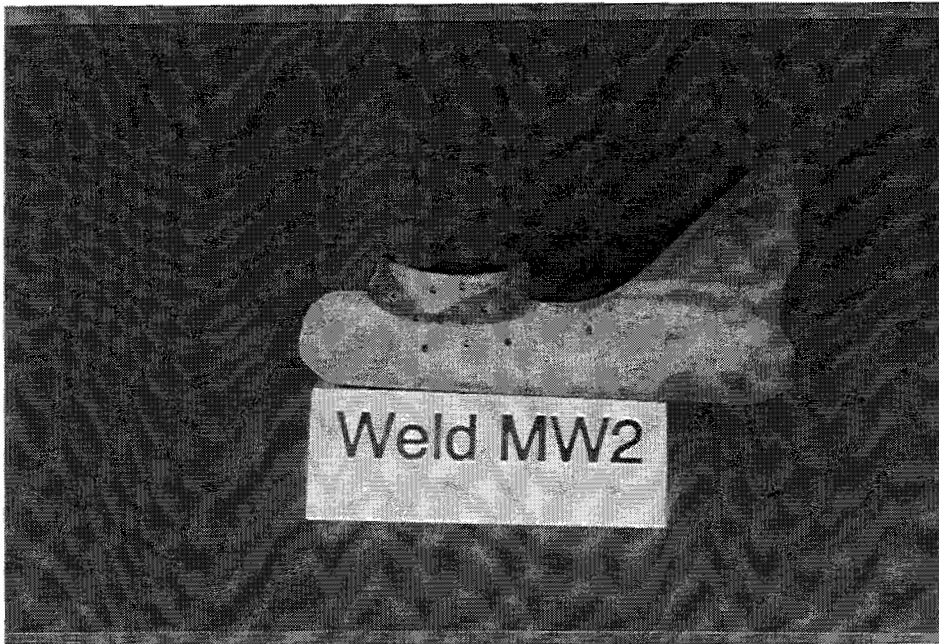

Figure 17 Weld Sample MW2

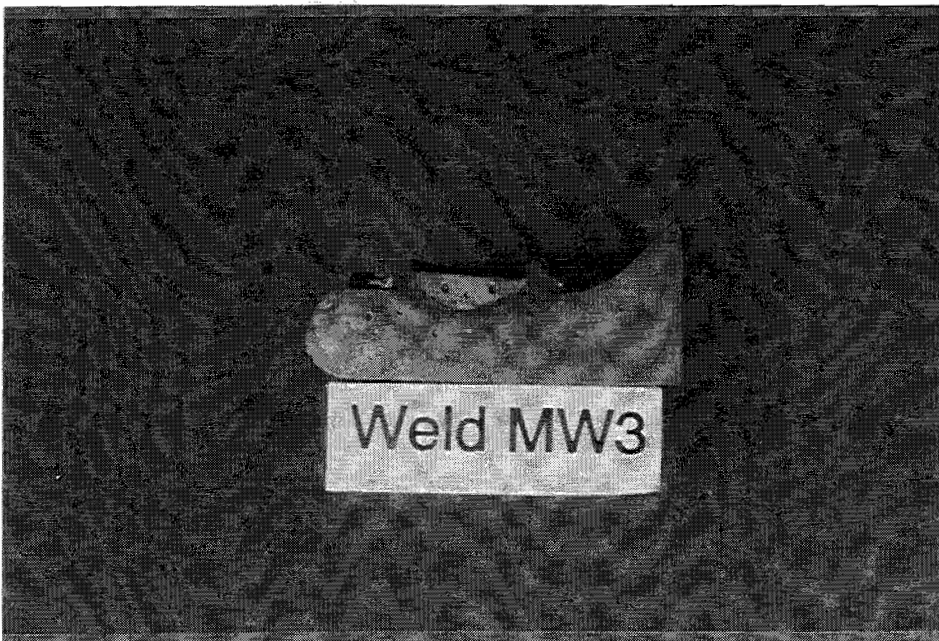

Figure 18 Weld Sample MW3



Figure 19 Weld Sample MW4



Figure 20 Weld Sample GW1

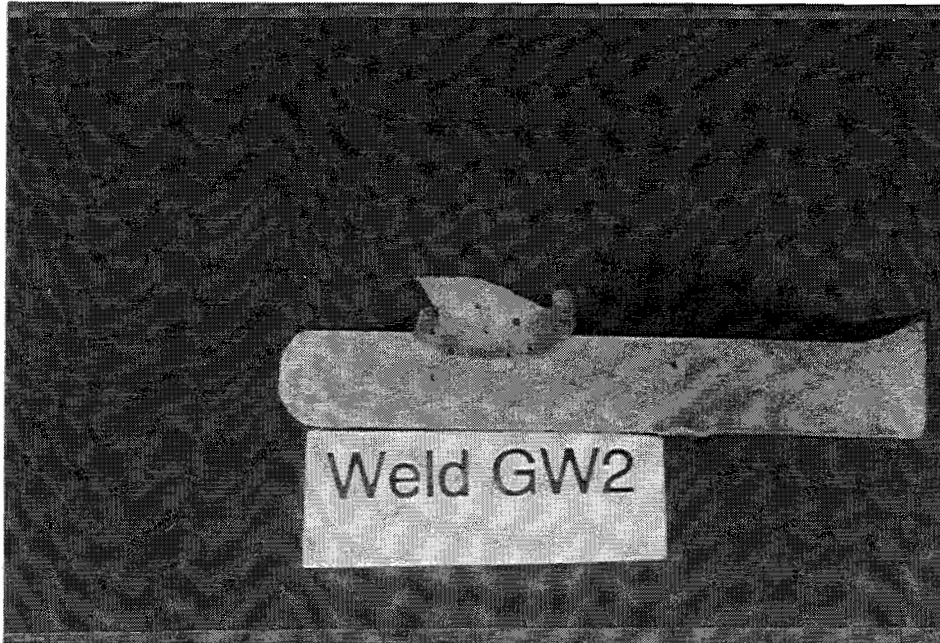

Figure 21 Weld Sample GW2

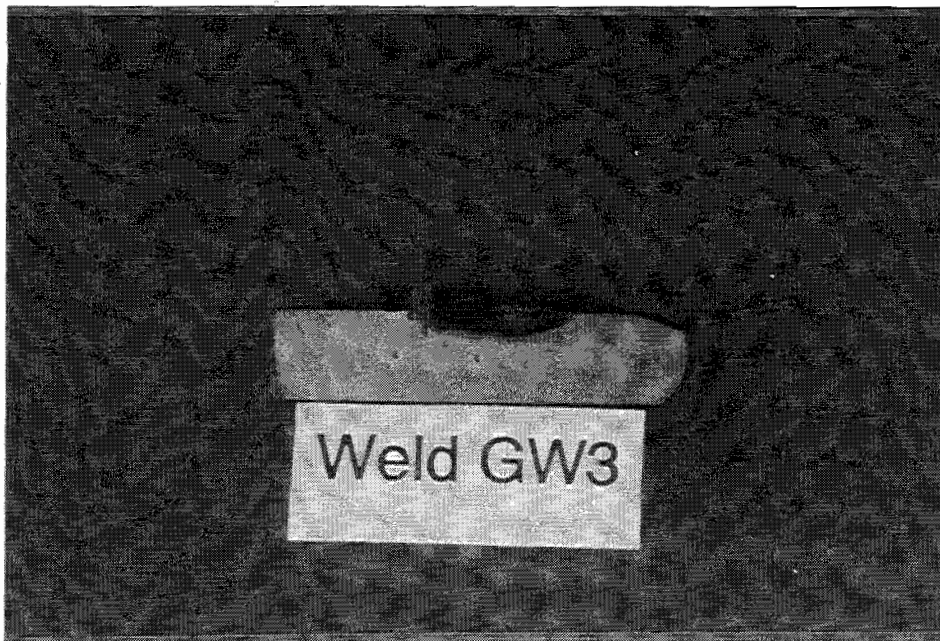

Figure 22 Weld Sample GW3

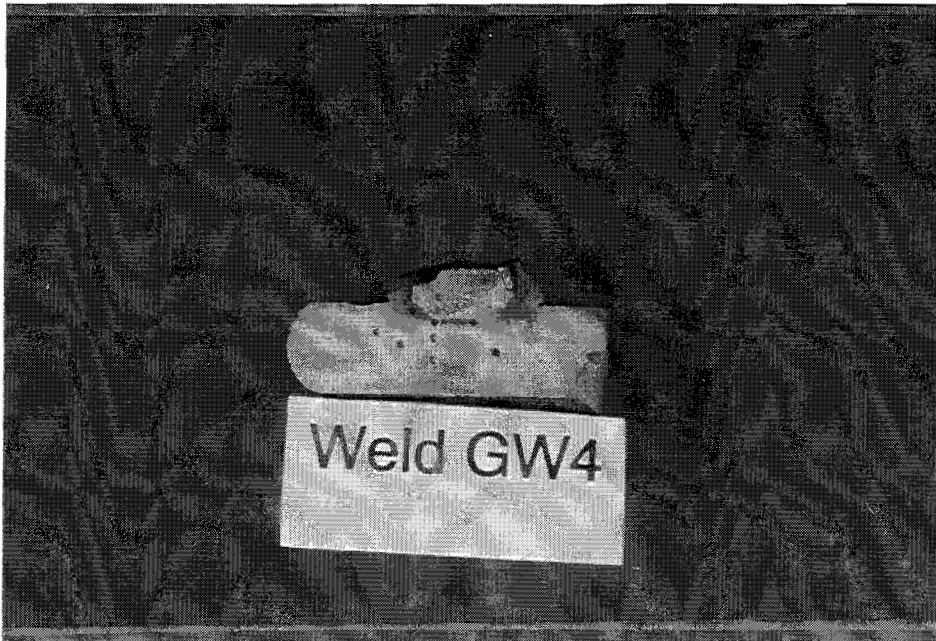

Figure 23 Weld Sample GW4

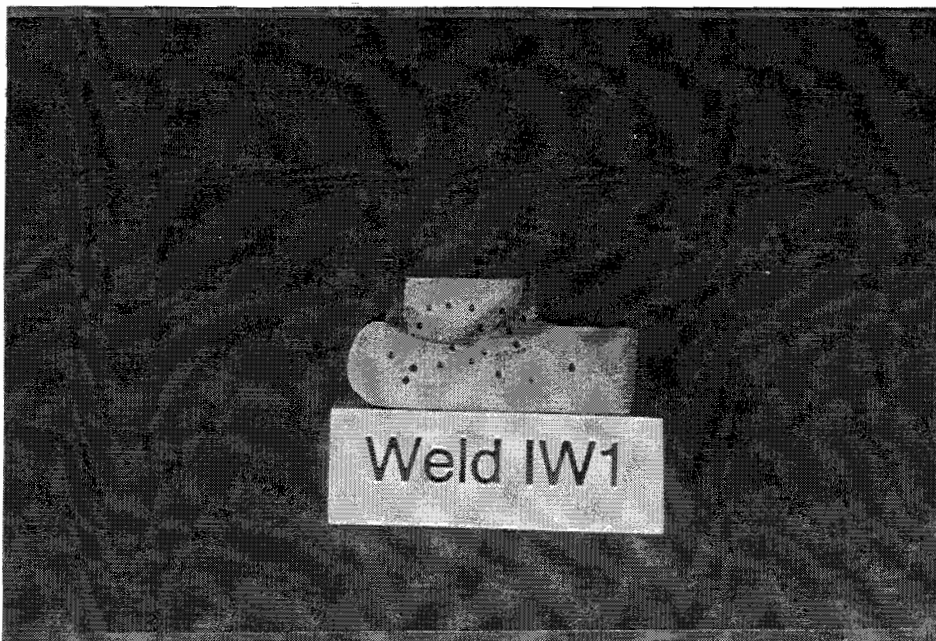
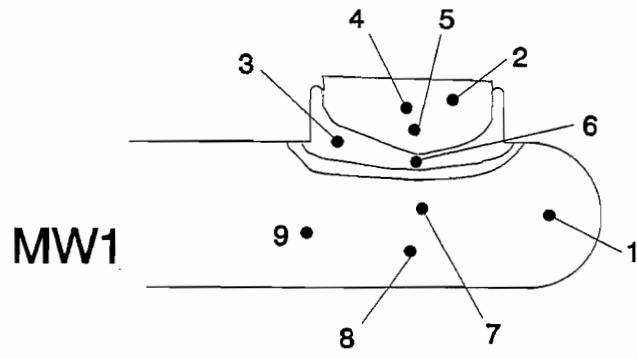
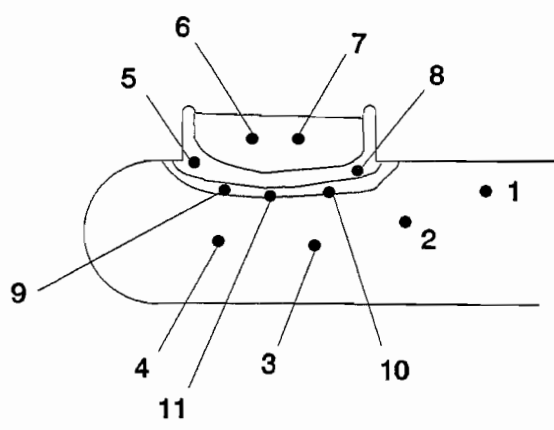

Figure 24 Weld Sample IW1



	1	2	3	4	5	6	7	8	9
R _c	9.0	14.9	32.5	9.8	11.2	29.0	14.1	10.8	10.1
Area	BM	ST	WM	ST	ST	WM	BM	BM	BM

Figure 25 Sample McAllen Weld #1



	1	2	3	4	5	6	7	8	9	10	11
R _c	-0.8	8.1	10.2	8.8	21.0	1.8	6.9	30.0	26.1	26.2	27.1
Area	BM	BM	BM	BM	WM	ST	ST	WM	HAZ	HAZ	HAZ

Figure 26 Sample McAllen Weld #2

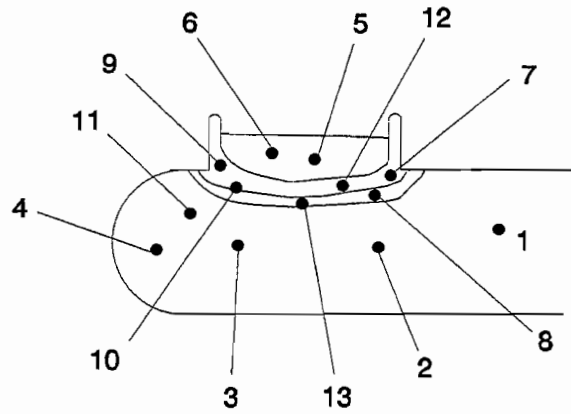

	1	2	3	4	5	6	7	8	9	10	11	12	13
R_c	3.1	5.0	7.2	5.9	-4.5	-0.8	29.1	29.9	27.6	30.8	8.1	23.0	22.9
Area	BM	BM	BM	BM	ST	ST	WM	HAZ	WM	HAZ	BM	WM	HAZ

Figure 27 Sample McAllen Weld #3

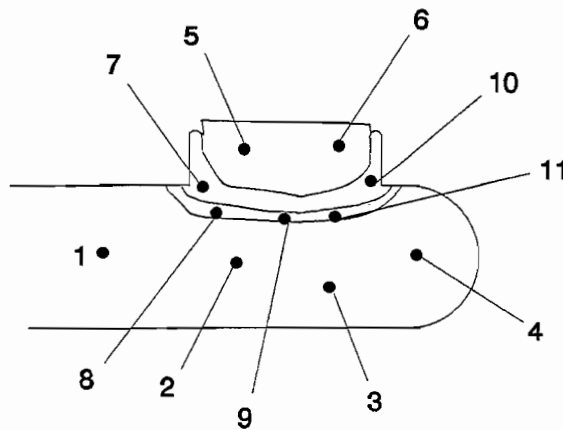

	1	2	3	4	5	6	7	8	9	10	11
R_c	4.4	8.6	7.9	7.5	9.8	11.8	16.0	21.1	25.1	29.5	30.8
Area	BM	BM	BM	BM	ST	ST	WM	HAZ	HAZ	WM	HAZ

Figure 28 Sample McAllen Weld #4

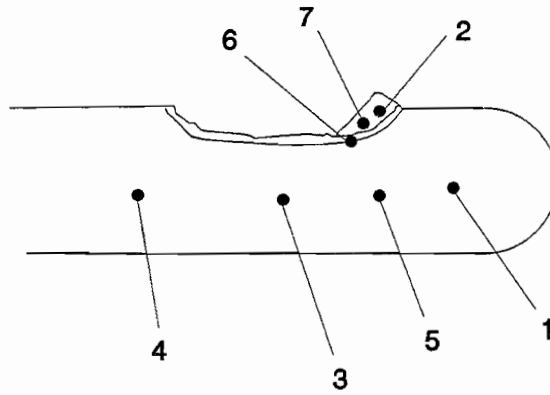

	1	2	3	4	5	6	7
R _c	-1.5	26.3	1.2	1.6	0.3	17.1	21.9
Area	BM	WM	BM	BM	BM	HAZ	WM

Figure 29 Sample Georgetown Weld #1

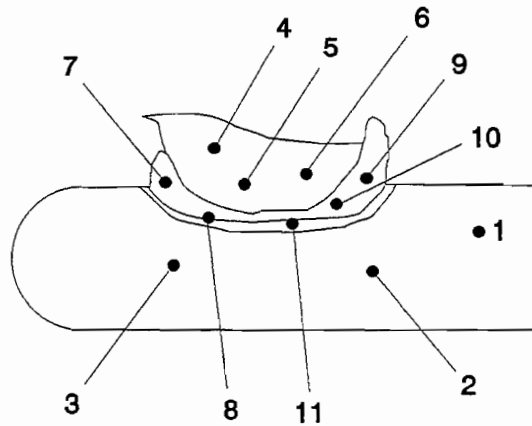

	1	2	3	4	5	6	7	8	9	10	11
R _c	-2.2	-2.2	1.2	21.9	12.1	17.3	28.9	21.1	28.0	27.2	18.4
Area	BM	BM	BM	ST	ST	ST	WM	WM	WM	HAZ	HAZ

Figure 30 Sample Georgetown Weld #2

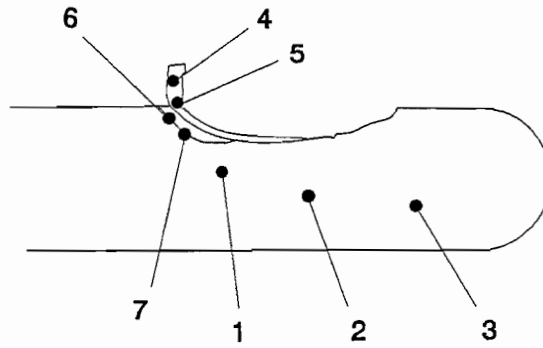

	1	2	3	4	5	6	7
R _c	2.8	1.1	-1.1	31.5	16.8	-2.0	7.0
Area	BM	BM	BM	WM	WM	HAZ	HAZ

Figure 31 Sample Georgetown Weld #3

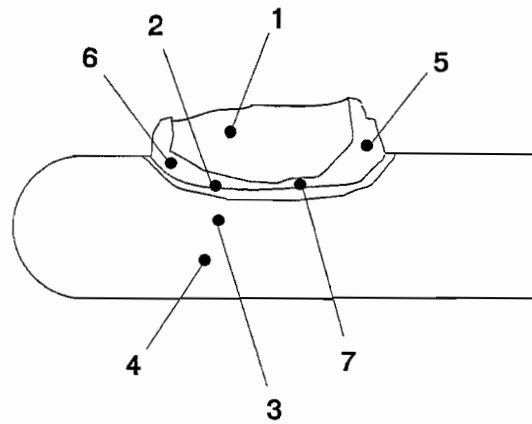

	1	2	3	4	5	6	7
R _c	12.0	12.9	4.1	3.0	30.1	28.0	10.4
Area	ST	HAZ	BM	BM	WM	WM	HAZ

Figure 32 Sample Georgetown Weld #4

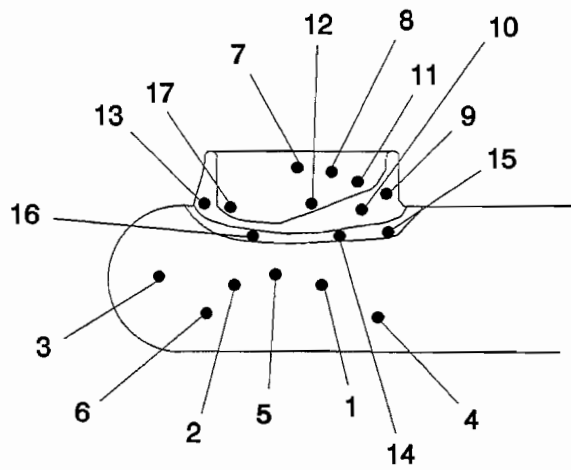

	1	2	3	4	5	6	7
R_c	-2.8	-2.1	-3.0	-6.9	1.5	-2.6	15.9
Area	BM	BM	BM	BM	BM	BM	ST

8	9	10	11	12	13	14	15	16	17
15.0	27.1	23.2	26.9	14.9	13.6	7.9	10.3	8.8	10.9
ST	WM	WM	ST	ST	WM	HAZ	HAZ	HAZ	ST

Figure 33 Sample Illinois Weld #1

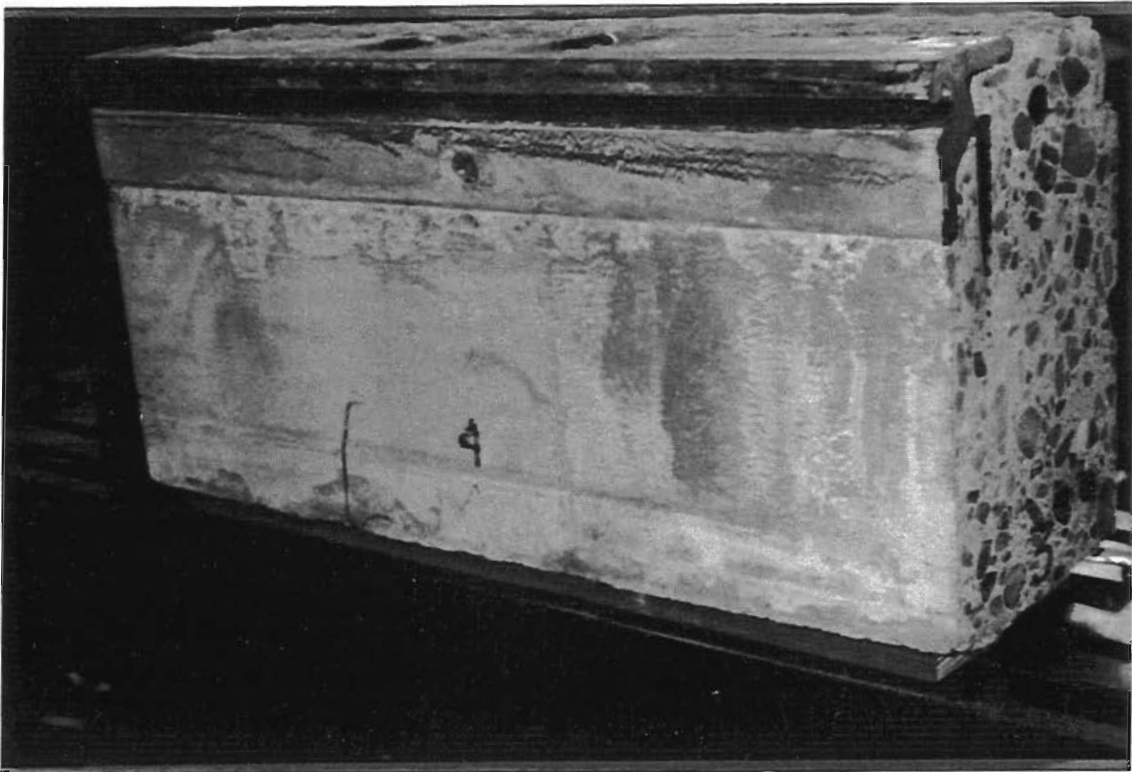

Figure 34 Front view of roadway section

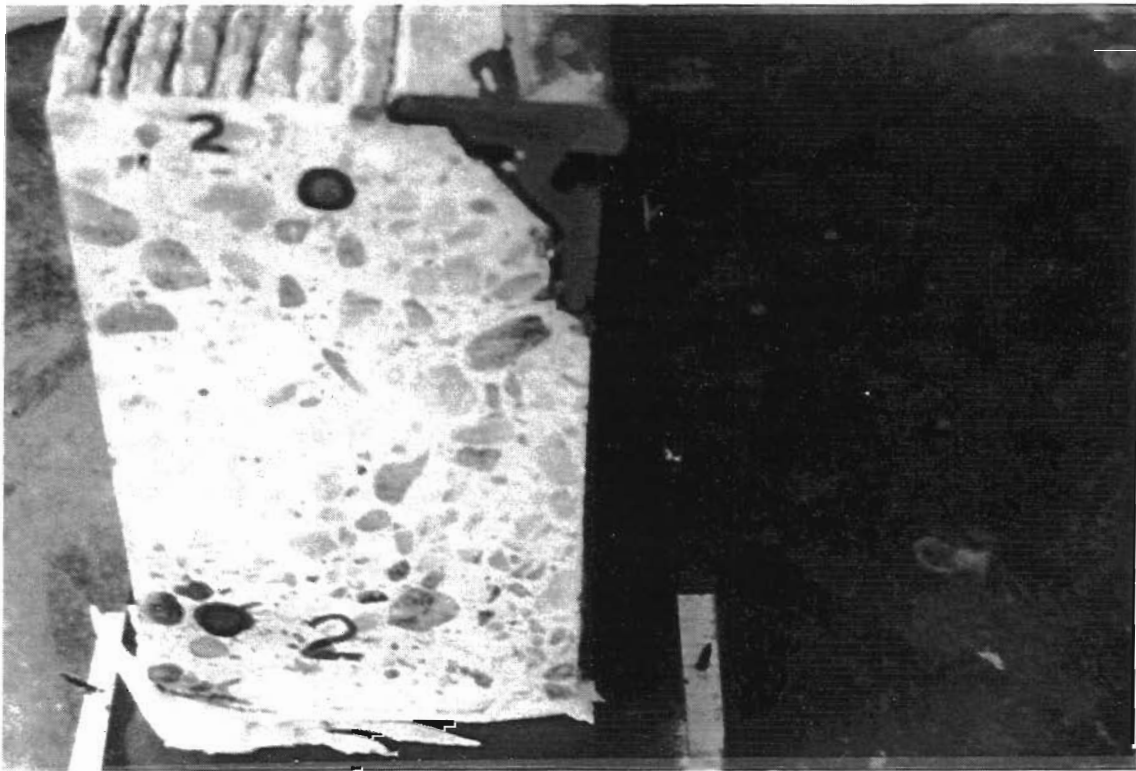

Figure 35 End view of roadway section

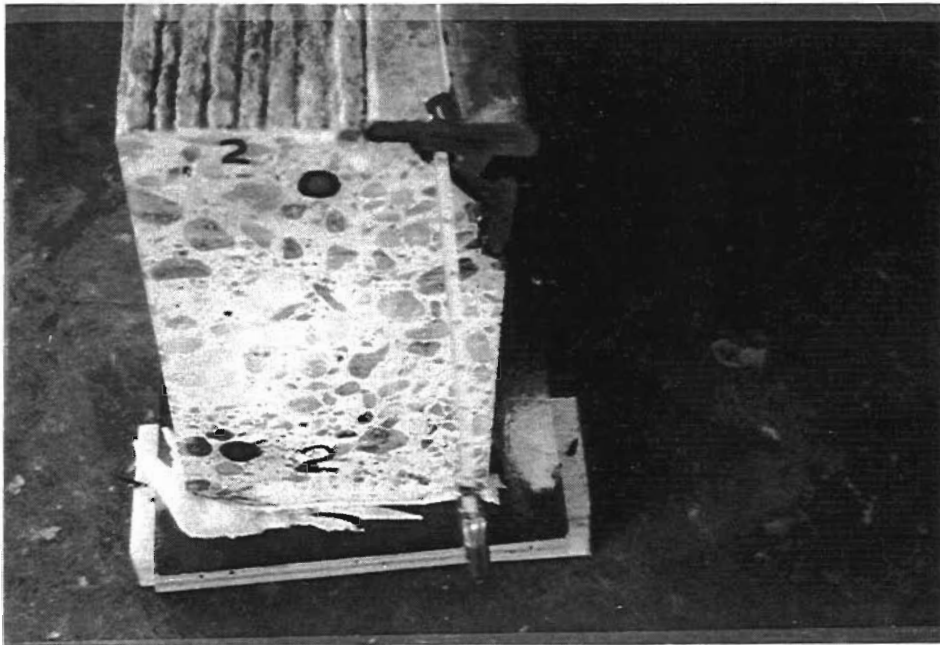

Figure 36 Approximately 2-in. void along end 2 and note reinforcing bar location (round dot)

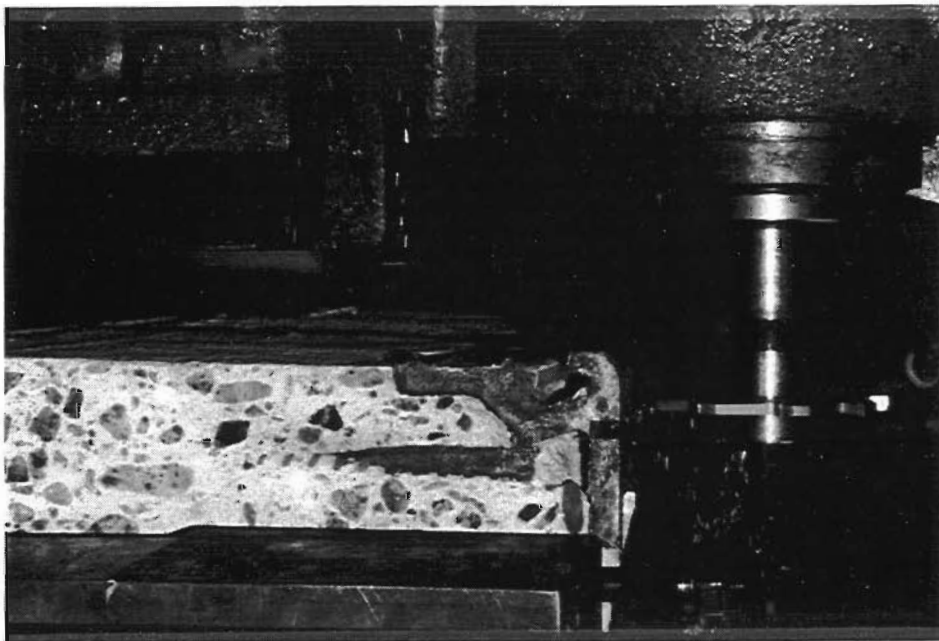

Figure 37 Void at end 3 also vertical reinforcing bar

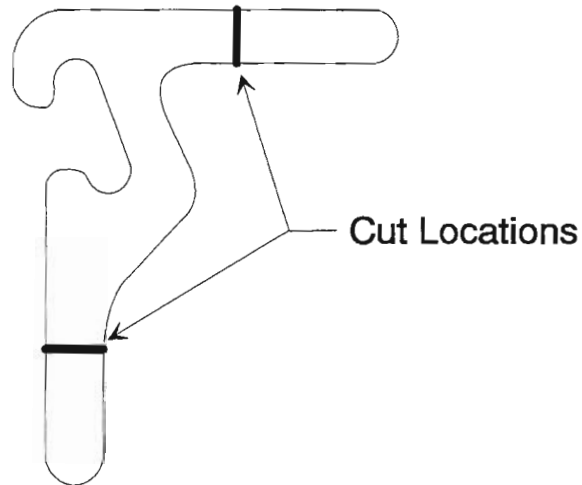

Figure 38 Locations of cuts to be made in rail

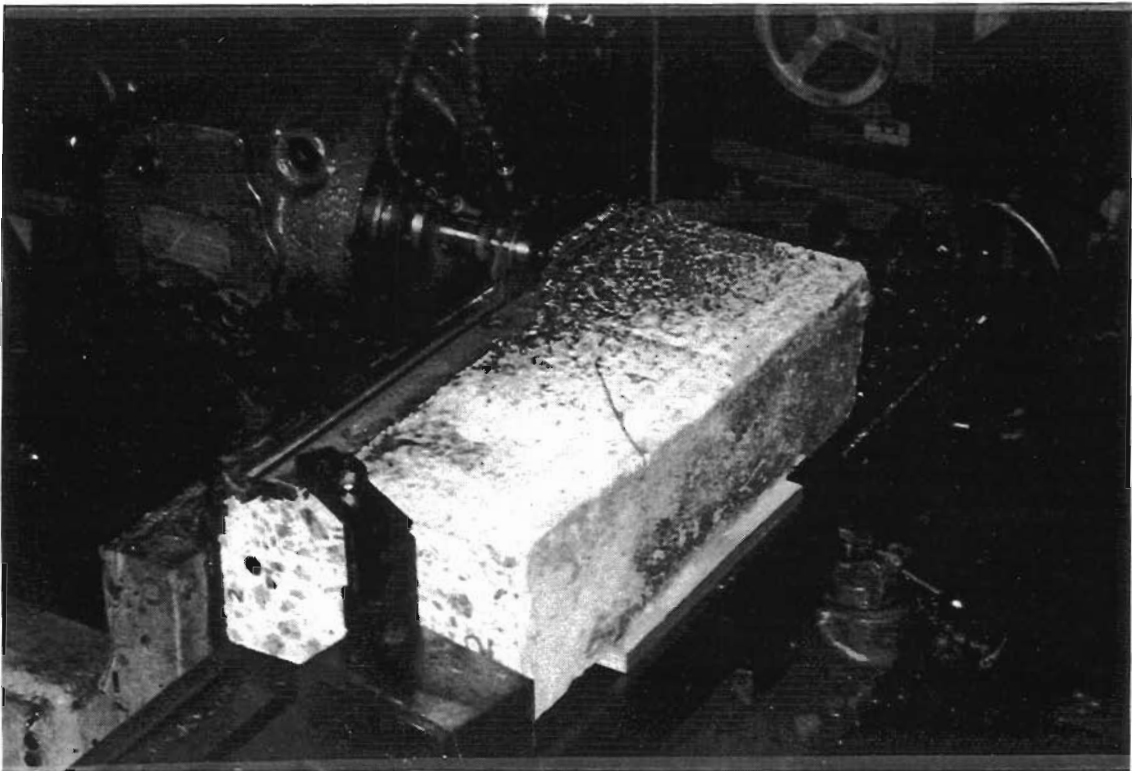

Figure 39 Roadway section in milling machine

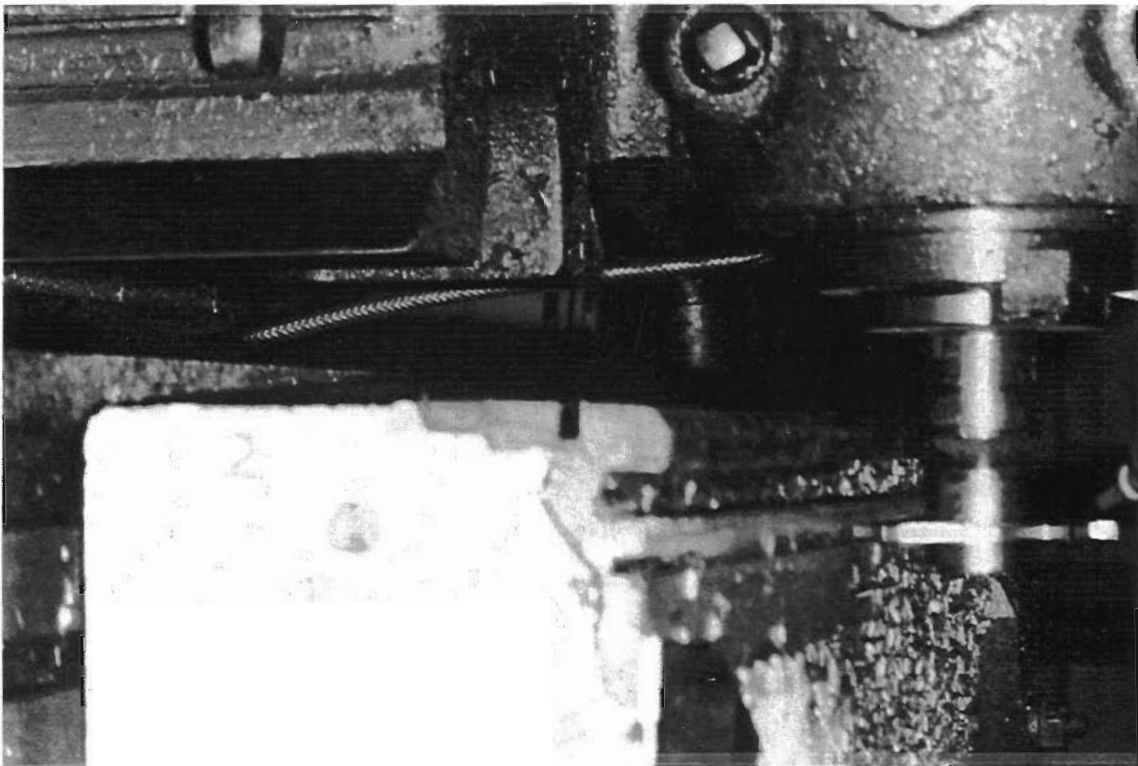

Figure 40 Roadway section in milling machine

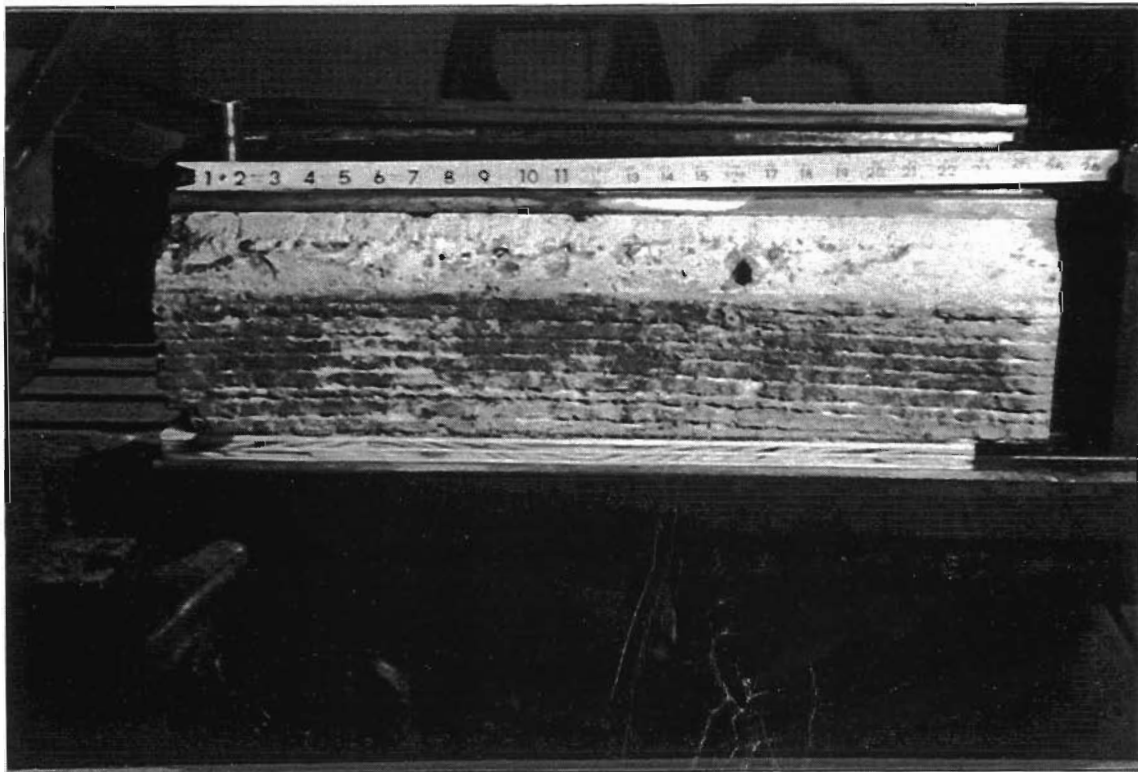

Figure 41 Rail section removed note lack of rail along roadway (raked) surface

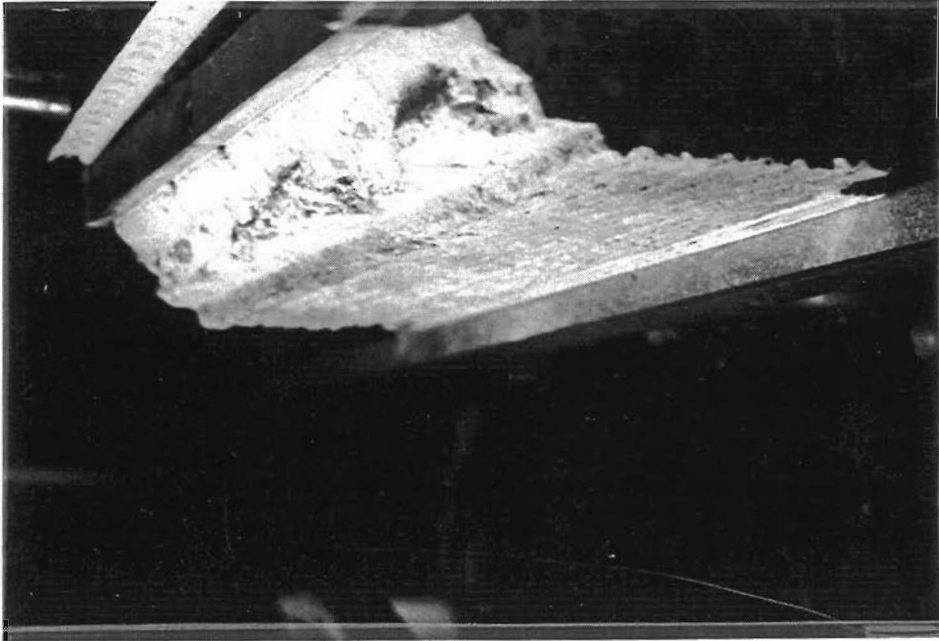

Figure 42 Edge view of roadway section after rail is removed

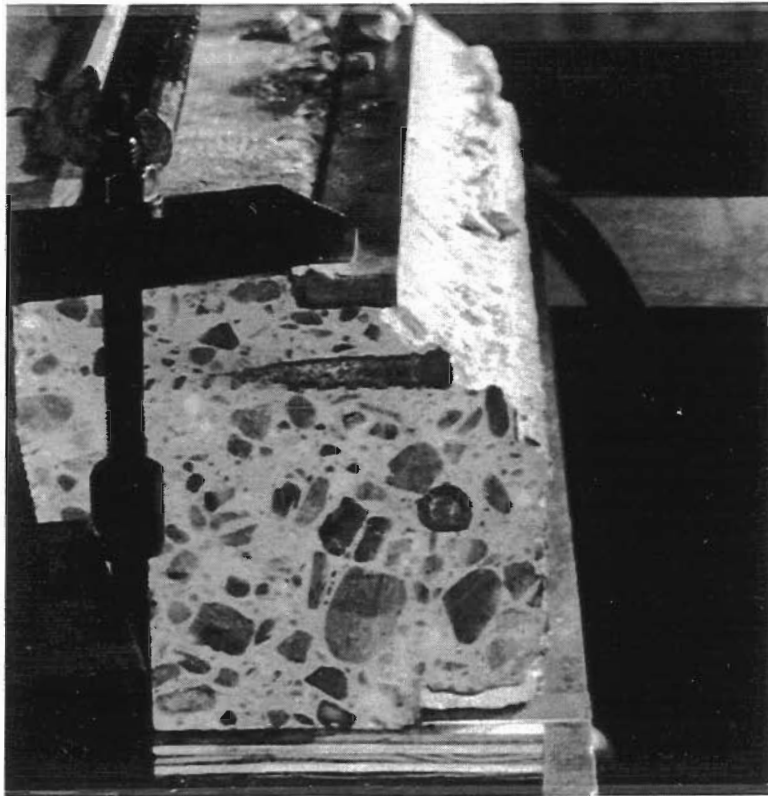

Figure 43 Edge view of roadway section after rail is removed

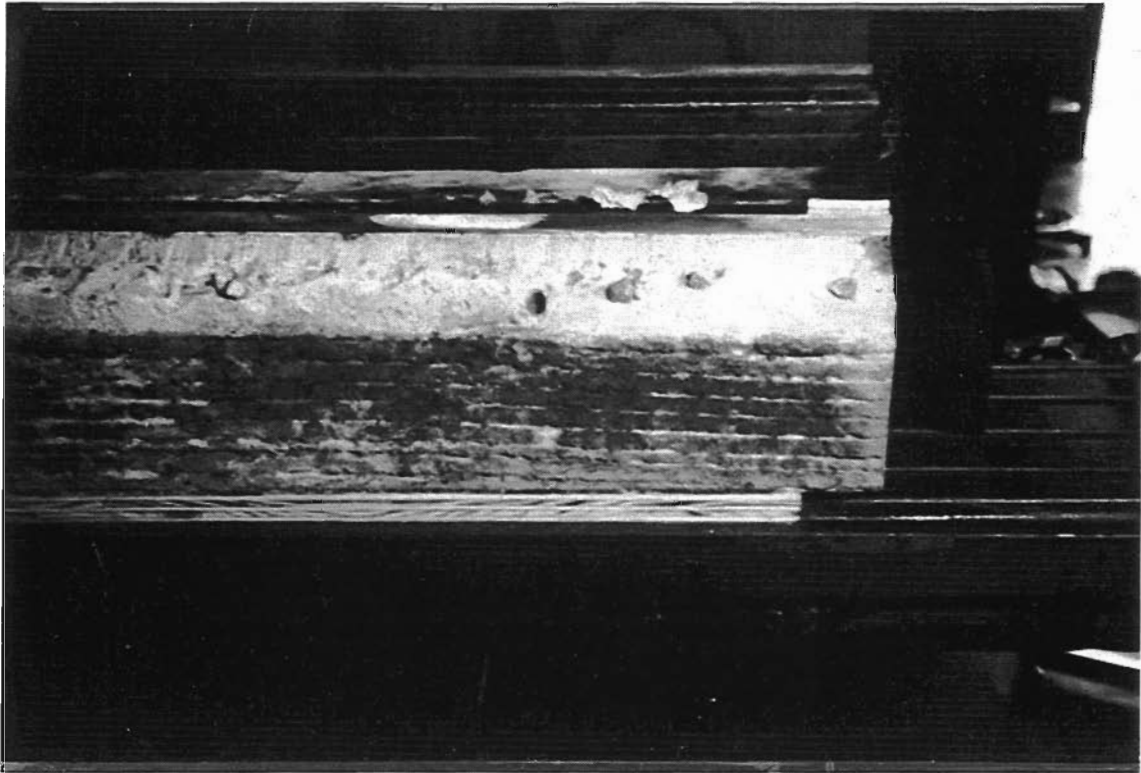

Figure 44 Concrete surface was pasty after removal of the rail section



Figure 45 The oval at the left near 2-in. shows a void underneath the rail

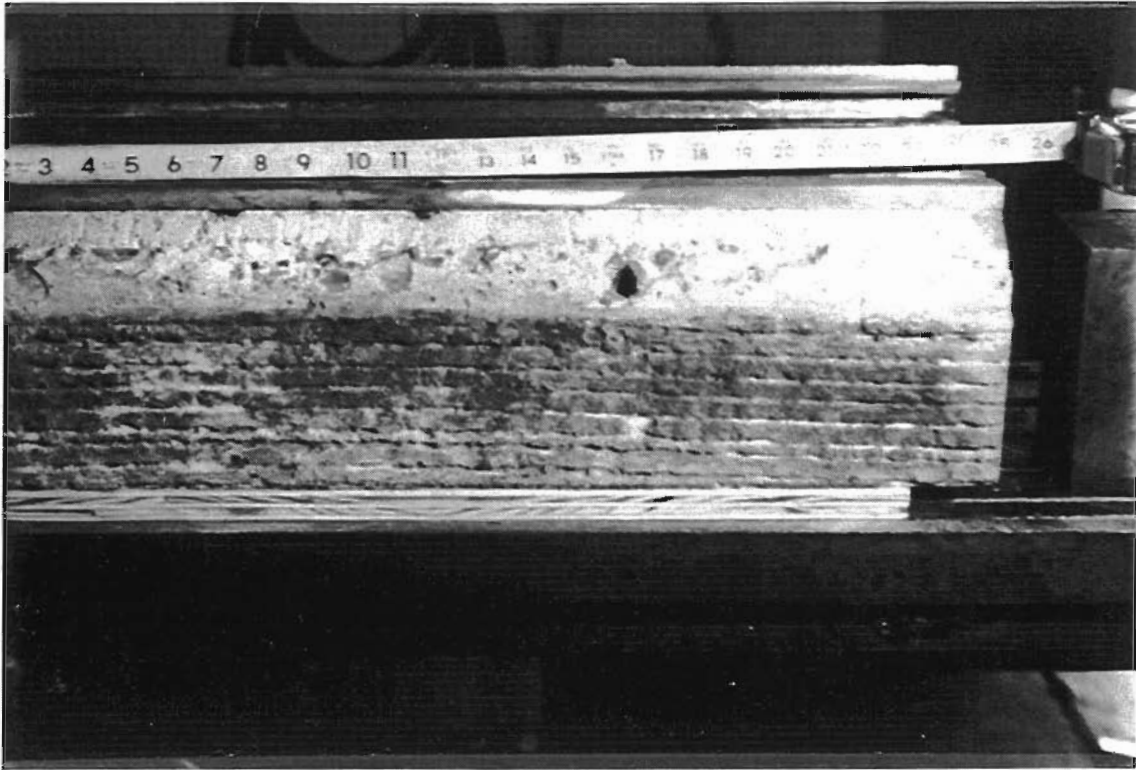

Figure 46 Studs were located at 7-in. and 17-in.

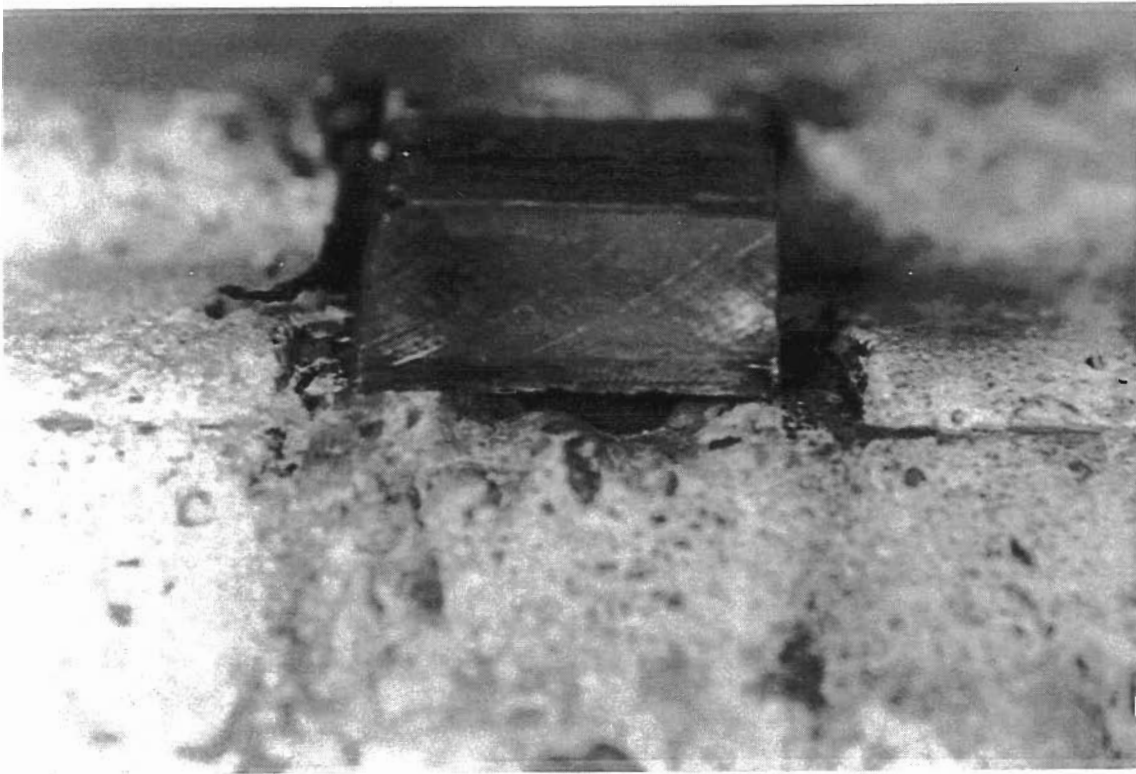

Figure 47 Small void at the base of the stud

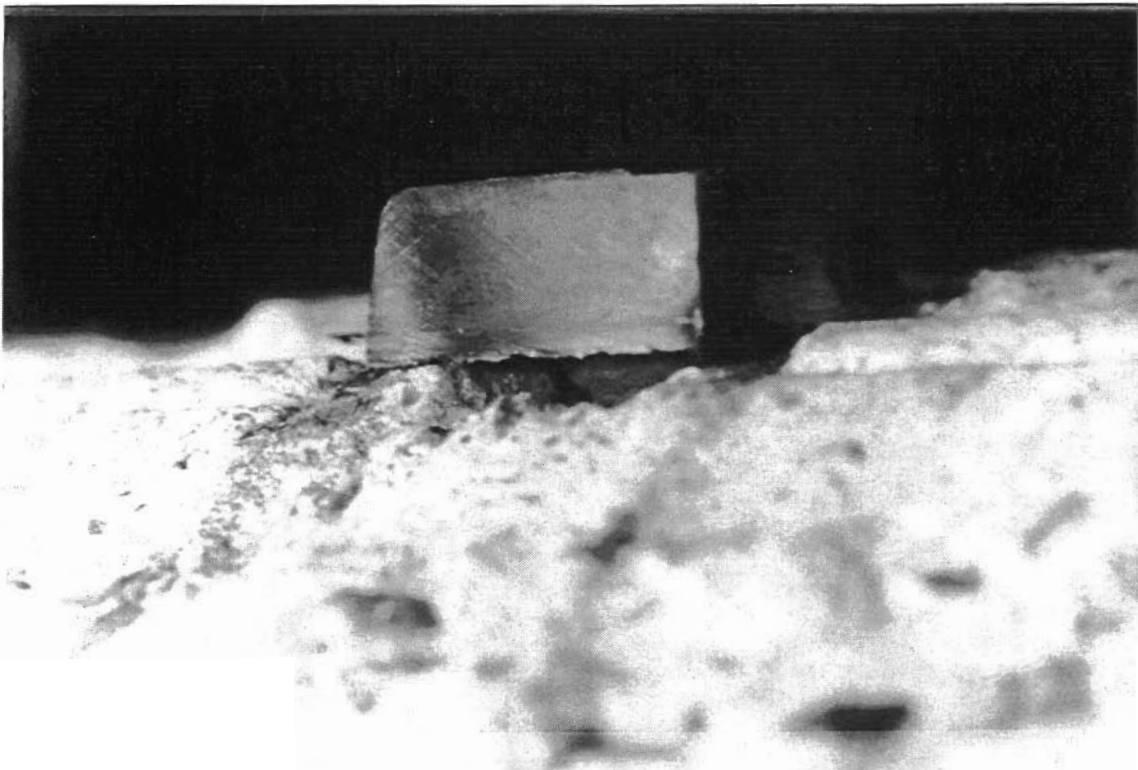

Figure 48 Small void at the base of the stud

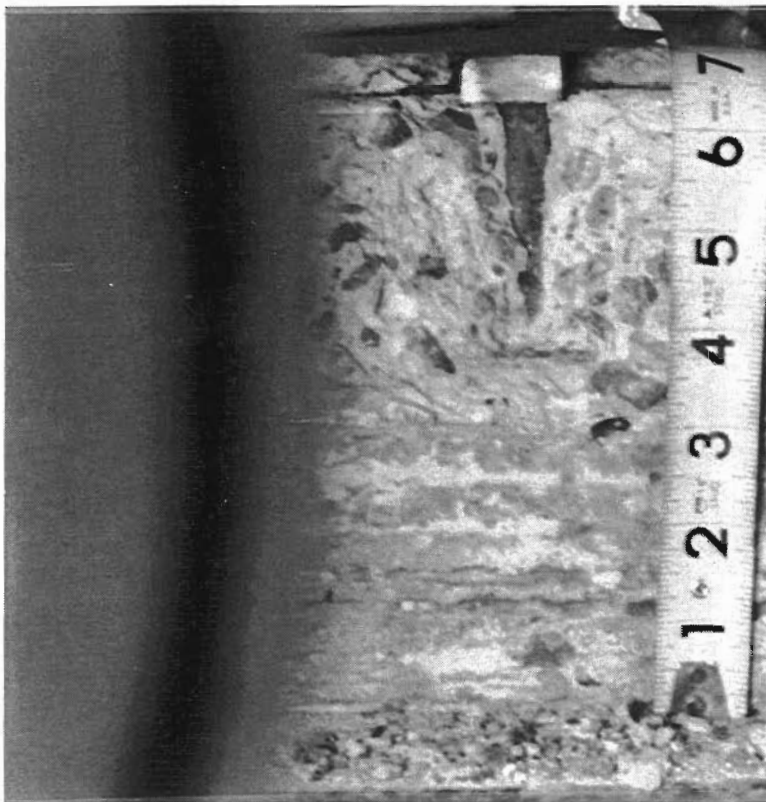

Figure 49 Excavation of stud in roadway section



Figure 50 Excavation of study in roadway section



Figure 51 Failure surface of excavated stud



Figure 52 Failure surface of excavated stud

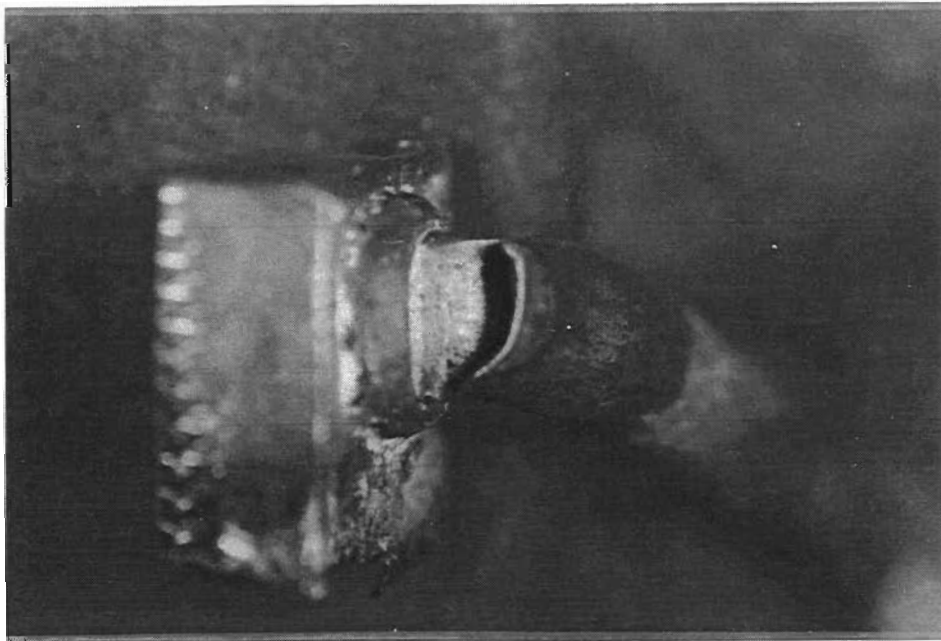

Figure 53 Failure surface of excavated stud

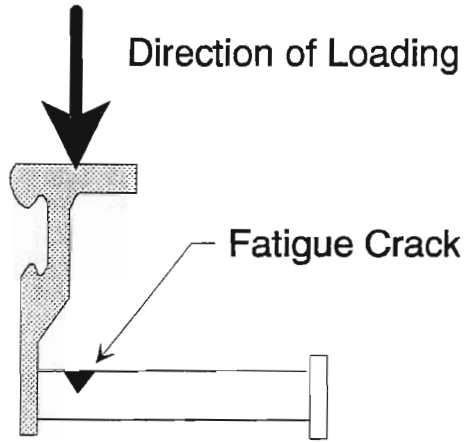

Figure 54 Orientation of crack in stud, rail and loading



Figure 55 Cross-section of roadway section after removal of stud

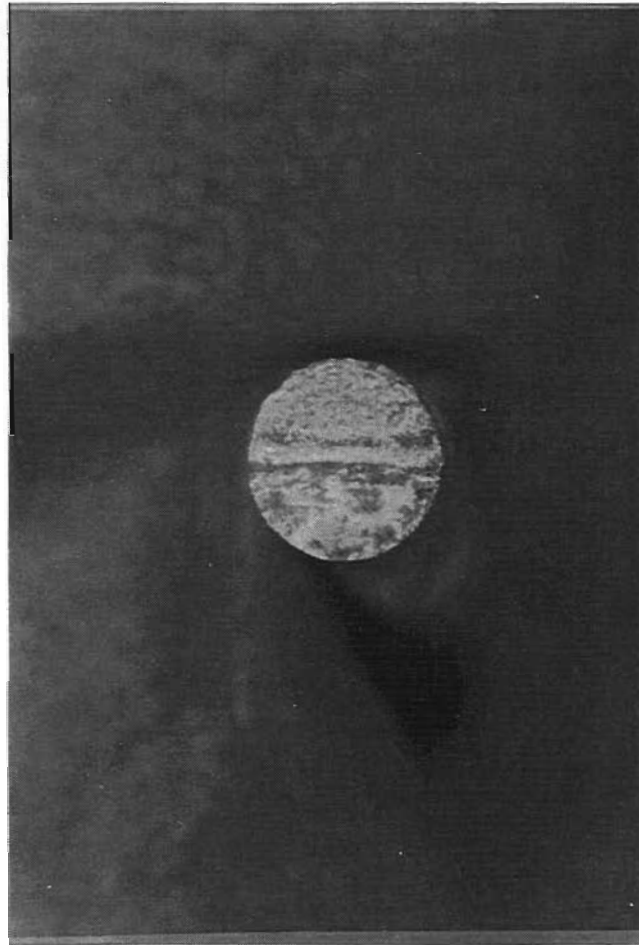

Figure 56 Fracture surface of second removed stud