

Ferguson Structural Engineering Lab Newsletter

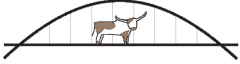

THE UNIVERSITY OF TEXAS AT AUSTIN - STRUCTURAL ENGINEERING

Volume 6, Issue 1

February 19, 2014

Welcome to New Faculty Members!

As we kick off 2014, we are happy to have two new faculty members joining us at FSEL: Patricia Clayton and Trevor Hrynyk.

Dr. Clayton comes to us from the University of Washington, where she received both her MS and PhD degrees, following a BS degree from North Carolina State University. Her research interests are focused on enhancing the seismic performance of structures, particularly through the use of self-centering and damage-mitigating technologies.

Dr. Hrynyk joins us from the University of Toronto, where he received his PhD, after obtaining his MS from University of Missouri-Rolla and his BS from the University of Waterloo. His research interests include the behavior and modeling

of reinforced and fiber reinforced concrete structures, blast and impact loading, and steel-concrete composite structures. We look forward to learning more about their upcoming research in future editions of the newsletter!



Patricia Clayton (left) and Trevor Hrynyk (right), our two new faculty members at UT and FSEL

Breen's Corner: FSEL's Sherlock Holmes and the Case of the Missing Astroturf

By J.E. Breen

When FSEL was first begun in Building 24 at the then-named Balcones Research Center (BRC) in 1960, the key person making it possible was Civil Engineering Professor J Neils Thompson, who was the overall Director of BRC. Neils was responsible for assigning the WWII surplus buildings at BRC to academic units. He saw that the overhead crane equipped building would make a great structures lab someday. Besides being a faculty member teaching materials courses and Director of BRC, Neils was also

Chair of the Men's Intercollegiate Athletic Council. For all practical purposes, Neils was also the UT Athletics Director, although that job was officially held by the legendary Coach Darrel Royal, who was busy building the championship football teams.

Memorial Stadium at UT was one of the first of the major football stadiums to switch from natural grass to artificial turf when Astroturf was

(Continued on page 2)

Inside this issue:

BREEN'S CORNER CONTINUED	2
NEW FACES AT FSEL	3
MORE NEW FACES, FALL GRADUATES, DEBONDING OF CFRP	4
STAY CABLE FATIGUE, AIR-COUPLED NDT	5
CFRP T-BEAMS, SPLICED GIRDERS, POST-INSTALLED SHEAR CONNECTORS	6
HIGH STRENGTH STEEL REBAR, TIME-DEPENDENT BUCKLING	7
SHEAR STUDS AT ELEVATED TEMP, BI-DIRECTIONAL CFRP, GALVANIZED SLIP-CRITICAL TESTS	8
CURVED PT DELAMINATION, PRECAST ARCH BRIDGE, ASR WALLS	9
BEARING PADS, PROGRESSIVE COLLAPSE	10
JNT GOLF TOURNAMENT	11

Ferguson Structural Engineering Lab Newsletter

Breen's Corner (continued from page 1)

installed in 1969. The early artificial turf did not hold up well and was rolled up and replaced in 1974. The Athletic Council made the decision to auction off the old turf in rolls. At the time, I was serving on the School Board at St. Austin's Catholic School, adjacent to UT. We decided to buy a roll of the turf to cushion our playground. We sent in our bid accompanied by a certified check. A week or so later, I was very surprised to receive a call from Neils telling me that while we were successful bidders, by some error in communications the entire field of Astroturf had disappeared! Apparently, the truck drivers had mistakenly taken it to the City of Austin landfill where it had been buried.

In the FSEL coffee break room, I talked this over with one of our long time technicians, retired Master Sergeant Gorham Hinckley of the US Air Force. "Hink" had had an illustrious career in the Air Force as "a dedicated scrounger". If you remember the character "Pigpen" from Peanuts, you will have a good impression of Hink. Our purchasing agent, Laurie Golding, always sent Hink

to get papers signed in important offices on campus because she knew nobody would want him standing around their work space very long. Hink was totally dedicated to the lab and would often come in on Saturdays to paint equipment setups so it would look good in report photos. He was loved by all for his dedication.

When I mentioned the disappearance to Hink, he said that he would get on the case. Our own Sherlock Holmes first went to the dump where he knew the attendants from having taken junk from the lab to dispose. They told him that they had no recollection of any UT trucks having brought loads of Astroturf to bury. (Think of the carpet needed to cover an entire football field, and you will understand that this would have been several very substantial loads to deliver.) Hink told me that he would stay on the case, and on several occasions reported tersely that he was making progress. I later learned that he had been hanging out both on campus and at BRC with the physical plant truck drivers at coffee time to get to know them better. One afternoon I was sitting in my office as FSEL Director when Hink appeared and, like always, saluted. "Sir", he said, (Hink called all the faculty, SIR) "Let's go up to Professor Thompson's Office." We went up to the BRC front building and into Neils's office. Hink said only to Neils "Please get the key to Building X (one of the very large storage buildings north of Building 5) Neils,

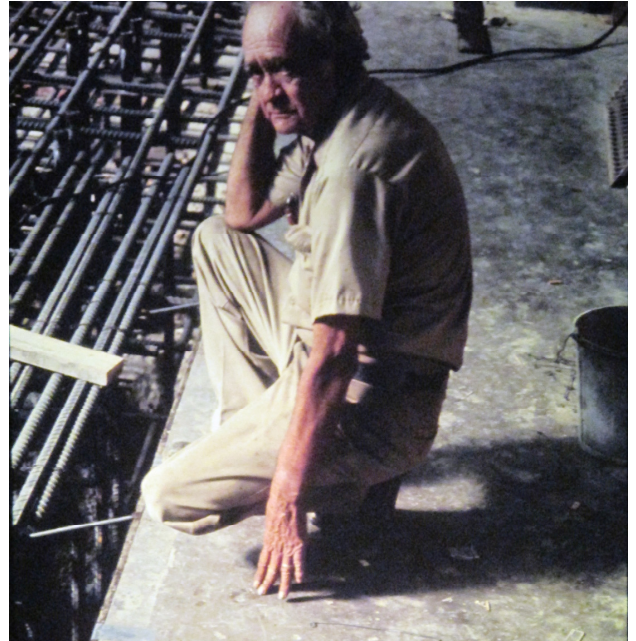

Master Sergeant Gorham Hinckley, aka "Hink," supervising the construction of the strong floor at FSEL

puzzled, did as requested and we went to that building. Upon opening the door and following Hink in, we came upon a mammoth pile of rolls of Astroturf. Hink had learned from some of the truck drivers that several drivers had hatched a plot to "borrow" the turf, store it in a UT building until it had been forgotten and then sell it privately.

Neils was extremely grateful, brought in the UT authorities to complete the investigation, and nicely gave St Austin's School a free roll of the Astroturf for its part in securing a Sherlock Holmes to unravel the mystery. Hink continued to serve the laboratory well, beloved by all of our students. If you are here the next time that we have STEER, ask the former students about Hink and you will hear many more great tales!

About the Author

Dr. John E. Breen is a Professor Emeritus in the Civil Engineering Department at UT-Austin following a 50+ year career as a faculty member at UT and an active researcher at FSEL. He has so many wonderful stories to share about interesting occurrences in FSEL's history that we try to capture in "Breen's Corner" articles in this newsletter.

New Faces at FSEL

Yafei (Sophie) Zhang



I came from Beijing, China and went to University of Wisconsin-Madison for my undergraduate degree. After spending four years in Madison, I feel winter in Austin is so lovely. When I am not studying, I like watching movies, reading

and travelling as much as I can. I am looking forward to making more friends (already got a few) at the lab and wish everybody an awesome 2014.

Daniel Elizondo

I was born and raised in Reno, Nevada. I earned my BS in Civil Engineering at the University of Nevada, Reno in the spring of 2013. I then decided to continue my education and pursue a master's degree here at UT. When I am not studying, I enjoy running, snow skiing, camping, hunting, fishing, and socializing with friends. I also enjoy music and have been to multiple concerts over the years. I look forward to my time here at UT and FSEL and being able to interact with all the great faculty and fellow students while obtaining a top notch education.



Chase Slavin

I was born in Connecticut and grew up there in the tiny town of Redding. I went to Lehigh University for my undergraduate education and, in 2013, received a B.S. in civil engineering as well as one in environmental science. I played volleyball at my undergraduate college and continue to play in a recreational league here in Austin. I really enjoy the outdoors and love being able to go hiking all winter since it's as nice as the summer weather that I grew up with. I'm looking forward to meeting all of my fellow students at FSEL.

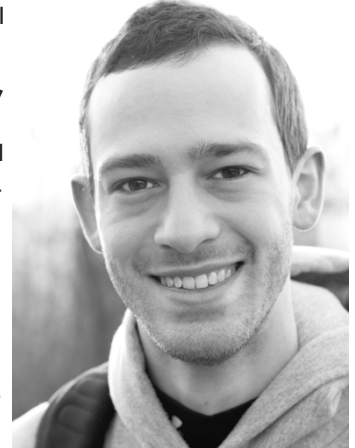

Beth Zetzman

I was born and raised in San Angelo, TX and am a fourth year undergraduate student in Architectural Engineering and Plan II Honors. Most of my time outside of school is spent hiking (and just being outside in general), going to concerts, and traveling to visit friends. I'm excited for this year at FSEL and look forward to meeting everyone!



Jun Zhang

I am a MS student in structural engineering. Originally from China, I got my undergraduate degree from Oklahoma State University and changed from a Cowboy to a Longhorn. And we both hate OU. I love many sports, especially soccer and basketball. My favorite NBA star is Kevin Durant who is a UT alum. I am very proud of that. I am very glad to come to FSEL lab and hope to know you all in the future!



More New Faces at FSEL



Joseph Klein

I was born in Houston but moved to DFW after elementary school. From a young age I always loved UT football so after high school I had no hesitation in picking UT. Four mediocre football seasons later, I completed my BS in Civil Engineering in December. Despite our difficulties in football, there is no place I would rather be pursuing my master's degree. When not in class or at the lab, I enjoy spending time outdoors with my dog, going to see live music, and reading. I am very excited for all of the learning opportunities at FSEL, and I can't wait to get to know everyone.

Sara Watts

I was born and raised in Temecula, California then I moved to Flagstaff where I completed my undergrad at Northern Arizona University. Finally I wandered far enough east to end up here in Austin to focus on structural engineering. My hobbies include playing the banjo, collecting antique silverware and saving orangutans. Excited to meet all of you as well!



Congratulations to the 2013 FSEL Fall Graduates!!



Fall 2013

- Ali Abu Yousef (PhD)
- Guillermo Huaco (PhD)
- Helen Wang (MS)

Ongoing Research at FSEL

Debonding Mechanism of CFRP - Wei Sun & Helen Wang



This research focuses on the transfer of force from CFRP (carbon fiber reinforced polymer) to concrete using anchors. Around 40 unreinforced 6x6x24" concrete beams have been built and strengthened by either 3" or 5" wide CFRP sheets to increase their flexural capacity. CFRP anchors have been

applied to ensure that the sheets reach their full capacity, instead of prematurely debonding before rupture. The debonding process and results are recorded and collected by a visual system. These results are then compared with numerical results from ANSYS simulations.

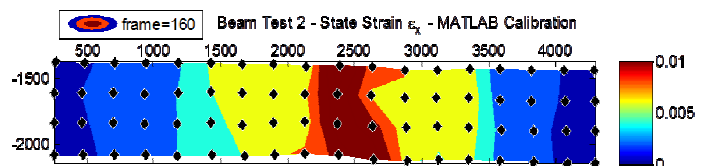

Parallel Mono-Strand Stay Cable Bending Fatigue Testing - Jan Winkler**

The recent cable anchorage failures on the Olav Sabo Bridge in Minneapolis indicate a lack of attention to the effect of cable vibrations on the fatigue lifetime and the cumulative fatigue damage of bridge cables. To date, only a handful of full-scale experimental investigations of stay cable fatigue under bending have been carried out.

The main goal of the full-scale bending fatigue tests on stay cables conducted at Ferguson Lab was to establish a correlation between the bending and fretting behavior of the single-strand and

that of the multi-strand stay cable. For this purpose, a digital image correlation (DIC) technique was employed as an efficient tool for quantifying the inter-wire movement and measuring individual wire strains along the length of the strand.

This research will lead to a simplified model that can be used for the assessment of stay cable fatigue behavior. With this research, one of the

***Jan was a visiting researcher at FSEL during the fall semester from the Technical University of Denmark and ATKINS*

most basic oversights in the lifetime assessment of cable-supported structures, namely the bending fatigue resistance of parallel mono-strand cables, is addressed.

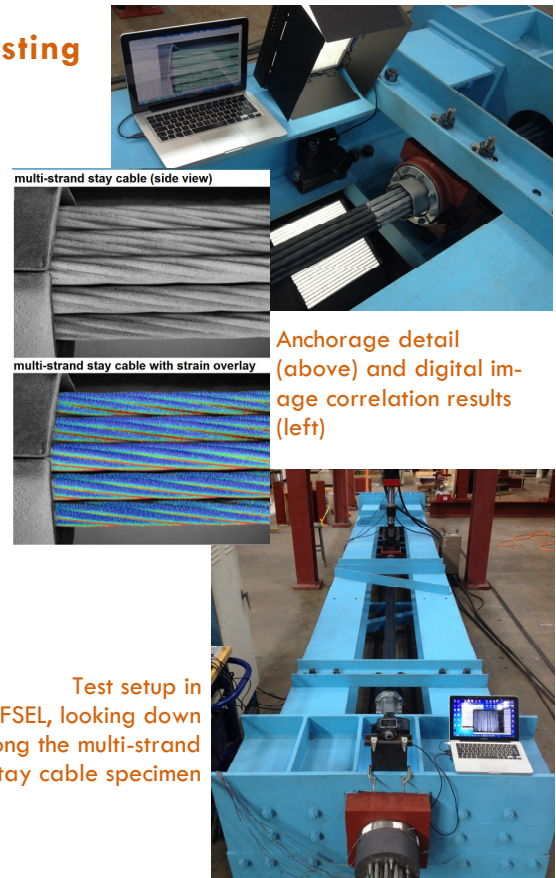

Anchorage detail (above) and digital image correlation results (left)

Test setup in FSEL, looking down along the multi-strand stay cable specimen

Air-Coupled NDT Methods - Xioawei Dai & Yi-Te Tsai

Our research is focused on developing a non-contact NDT system for use with concrete slabs. This system is comprised of a spark source, which is amplified by a parabolic reflector, and a microphone sensor. Previous results have showed that this system is very feasible.

We have switched to 3D printing to make our source reflector. Compared with our old aluminum-machined reflector, the new printed reflector is much lighter and has only a small amount of energy output drop. It also makes rapid prototyping possible so we can quickly change the geometry of the reflector.

On the sensor side, we added an extra microphone outside the parabolic reflector. This microphone will measure the leaky acoustic noise from the spark source. The measured noise will be used as input for independent component analysis (ICA). The ICA can separate two linearly mixed independent components, which in our case are the signal response from the slab and the noise that propagates through the air. By using the ICA algorithm, our test setup can obtain the same result from a concrete slab with a delamination as do traditional contact methods.

Our next goals are to (1) scale down the physical size of the system so it can be mounted on a moving vehicle, and (2) to test the system on materials other than concrete,

such as CFRP. Because the CFRP layer will need less energy than concrete to excite, we may be able to use a smaller spark device, which will make the whole system portable.



Current prototype of air-coupled NDT system

Ferguson Structural Engineering Lab Newsletter

Bi-Directional Application of CFRP for T-Beams - Nawaf Alotaibi, Will Shekarchi & Jun Zhang



The team is slowly transitioning from structural engineering into photography...

Recent studies have indicated that the bi-directional application of carbon fiber reinforced polymers (CFRP) can significantly increase the shear capacity of reinforced concrete beams. The team has been hard at work

constructing and testing T-beams with various span-to-depth ratios and CFRP layout schemes to help quantify these strength increases, as well as to determine the interaction between the steel stirrups and CFRP strips. In recent tests, conventional data acquisition methods have been forgone in lieu of a

more novel approach. We have begun to depend solely on the Vision System (an in-house program) to determine displacement and strain data from the movement of target pixels within an image. In the coming months, we hope to cast two more specimens and complete six tests by late March.

Spliced Prestressed Concrete I-Girders - Andy Moore, Chris Williams, Dhiaa Al-Tarafany & Josh Massey

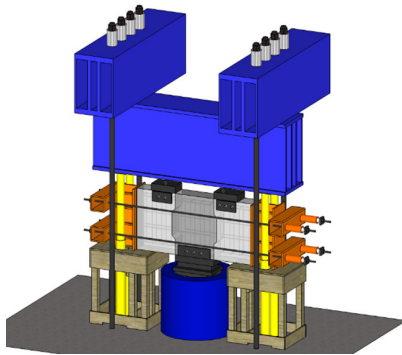

3D rendering of test setup for upcoming interface shear tests

The spliced girder team has finished the last of the eleven tests investigating the shear behavior of spliced post-tensioned girders and are now preparing for tests to study the performance of cast-in-place (CIP) post-tensioned splice regions. Formwork for the CIP regions is being

fabricated, and a mock-up will soon be cast to evaluate a concrete mix design that will potentially be used for the test specimens.

The team is also preparing for shear tests to study the strength of the interface between the precast girders of spliced girder bridges and

the CIP splice regions (see figure). Panels meant to represent the webs of highway bridge girders are being fabricated. Various interface details will be tested, such as saw teeth and shear keys, in order to evaluate their relative strengths and determine which are most appropriate for spliced girders.

Strengthening Continuous Steel Bridges with Post-Installed Shear Connectors - Kerry Kreitman, Amir Ghiami & Sophie Zhang

Test setup at the start of the semester...

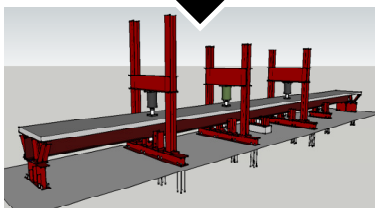
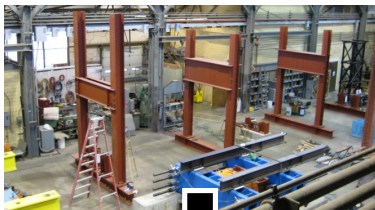

...and in the future!

One potential method of strengthening older, non-composite steel I-girder bridges is to “post-install” shear connectors to create composite action between the existing concrete deck and steel girders. These unconventional shear connectors are installed by drilling holes into the flange of the steel girder and the concrete deck, and inserting high strength

bolts or threaded rods to form a mechanical connection between the two materials.

Research into the feasibility of using these shear connectors to strengthen existing bridges is ongoing at FSEL. Currently we are focused on constructing a test setup in the laboratory to test an 85-foot long, two-span steel beam, made composite with a 6.5-

foot wide concrete deck using post-installed shear connectors. The specimens will be tested under several loading conditions, including rapid fatigue loading cycles to simulate normal traffic loads, and slower loading cycles to simulate the passage of heavy trucks. Keep an eye on our progress in the lab and look out for some exciting tests in the near future!

High Strength Steel in Reinforced Concrete Columns - Drit Sokoli & Chase Slavin

The congestion of reinforcement in concrete columns in seismic areas can be reduced by using higher strength steel bars. However, the potential usage of high-strength steel (HSS) brings up a lot of uncertainty and discussions, mostly related to the decrease in ductility that comes with the increase in strength. This study aims to assess the behavior, stiffness, and

strength of seismically detailed columns reinforced with HSS, as compared to columns reinforced with Gr 60 reinforcement, which is widely used and well accepted by many building codes. Another point of interest that will be addressed in this project is the ACI 318 limitation of 60 ksi for the shear reinforcement design.

Two columns, reinforced with Gr 60 and Gr 80 steel, respectively, were tested at FSEL last semester. A third column, with Gr 100 reinforcement, will be cast and tested during the spring semester. All columns have the same grade steel for both longitudinal and transverse reinforcement. The first two tested columns showed comparable behavior and exceeded minimum necessary performance objectives by a substantial margin. Stay tuned - the Gr 100 test is about to come!



Specimen before testing

Hysteretic behavior of a column specimen

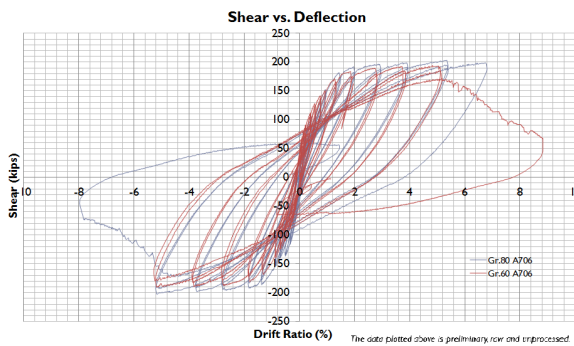

Time-Dependent Buckling of Steel Columns Subjected to Fire - Ali Morovat

Along with the main goal of developing a fundamental understanding of the phenomenon of creep buckling, this project has shown that time-dependent effects are significant in the response of steel columns in fire conditions.

Now, with the buckling tests on W4x13 columns nearing the end, the methodology developed to account for the effect of material creep on the buckling of steel columns in fire can be further verified. An example of such

verification is shown where analytical and computational creep buckling predictions are compared against test results for W4x13 columns with KL/r of 51 inches, tested at 600°C. Analytical solutions are based on the concept of a time-dependent tangent modulus. Computational creep buckling analyses have been performed in Abaqus®. A material creep model developed in this study for ASTM A992 steel is utilized in analytical and computational buckling analyses. Considering all of the uncertainties in material creep models and buckling prediction methods, reasonably well agreement can be seen between the experimental results and the predictions.

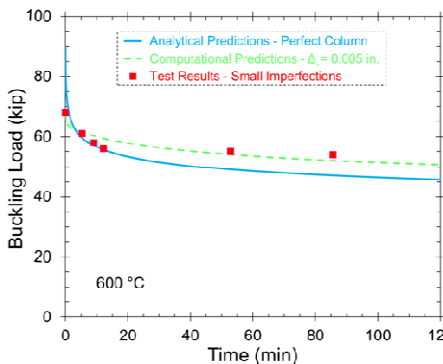

verification is shown where analytical and computational creep buckling predictions are compared against test results for W4x13 columns with KL/r of 51 inches, tested at 600°C. Analytical solutions are based



All good things come to an end, even at FSEL!

Ferguson Structural Engineering Lab Newsletter

Behavior of Shear Studs in Composite Beams at Elevated Temperatures - Sepehr Dara

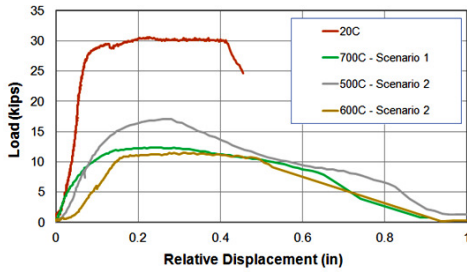

Examples of load-displacement behavior

The goal of the experimental testing phase of this research study is to capture the load-displacement behavior of a shear stud at different temperatures. A total of ten specimens, consisting of a small concrete block attached to a steel plate with a shear stud, have been tested under two heating scenarios, includ-

ing one test conducted at room temperature. In the first heating scenario the specimen was loaded shortly after the furnace temperature reached the desired temperature. Formation of a temperature gradient inside the specimen was expected and occurred in these tests which were conducted at 500, 600, 700, and 760°C. In the second heating scenario the specimen was heated and then kept at

the target furnace temperature until a relatively uniform temperature distribution was observed inside the specimen. Furnace temperatures in this heating scenario were 300, 400, 500, 600, and 700°C. In all of the tests, failure occurred when the shear stud was sheared off above the weld to the steel plate. However, different strength and ductility were observed in each test (see figure).

Bi-Directional Application of CFRP for Shear Strengthening of Reinforced Concrete Bridges - Changhyuk Kim

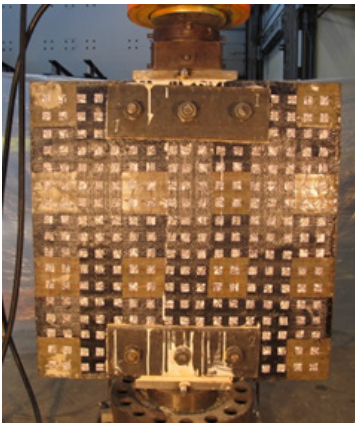

Test specimen with bi-directional CFRP strips

The objective of the study is to demonstrate the feasibility of using bi-directional CFRP for shear strengthening of large bridge I- and U-beams. Tests of deep beams with both uni-directional and bi-directional CFRP strips have indicated that the use of bi-directional strips leads to significantly greater increases in shear capacity. A total of nineteen panels, without and with CFRP anchors, have been tested under compressive forces applied over a re-

stricted area. Such loading will generate a bottle-shaped compressive strut between loading and reaction points. As panel test results become available, we will focus subsequent tests on targeting the most influential parameters, such as CFRP strip inclination and ratio of CFRP strip to CFRP anchorage. The last series of test specimens has been cast and will be tested in

the next month. The purpose of these tests is to evaluate the contributions of the concrete, steel reinforcement, and CFRP strengthening to the capacity of the panels.

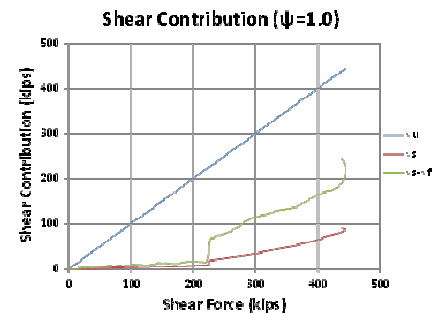

Slip-Critical Performance of Galvanized Steel - Sean Donahue

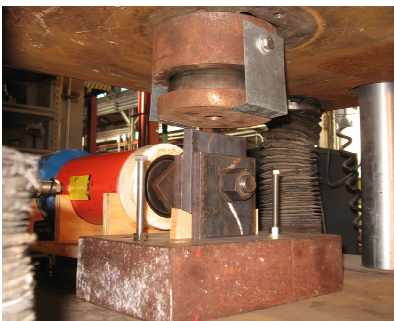

Slip-critical testing

Galvanized steel has historically been assumed to behave very poorly in slip, but this assumption is based largely on research conducted several decades ago. Modern galvanizing practices are quite different from the techniques used at

the time of initial testing, and may result in significantly different slip behavior. Slip tests will be done looking at a variety of different galvanizers, as well as different pre-treatments and post treatments used by galvanizers, to determine if the slip coefficient of modern galva-

nized steel should be changed, and what parameters affect its behavior. Initial tests done on galvanized plates suggest that the current assumption is overly conservative, with galvanized plates slipping at loads similar to uncoated steel.

Delamination of Curved Post-Tensioned Structures - Jongkwon Choi

Over the last year, we focused on the detailing of the curved post-tensioned (PT) wall specimen. A lack of experimental data on such structures required the investigation and implementation of a number of assumptions during the design/detailing process. A pilot test will provide more insight into the behavior and strength of curved PT walls, and will thereby enable refinement of the experi-

mental program. We are currently procuring materials for the pilot specimen, and fabrication is expected to begin this semester.

We have also started analyzing the problem through the use of VecTor2, which is a nonlinear analysis program of two-dimensional reinforced concrete membrane structures. The advantage of the VecTor program is that

state-of-the-art theories regarding concrete nonlinear behavior, such as MCFT and DSFM, are already included. Through analysis, we hope to develop meaningful estimates for the capacity of the curved PT wall, expected failure modes, the influence of size-effect, and others.

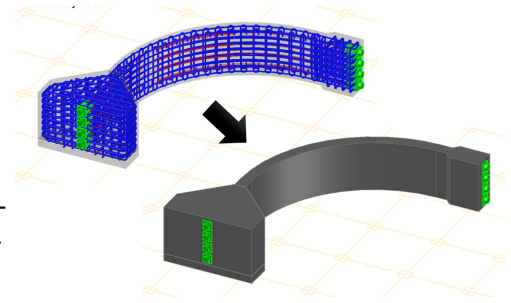

Schematic of pilot test specimen

Monitoring Stresses in Prestressed, Precast Concrete Arches - Hossein Yousefpour

This fall semester, the construction of the one-of-a-kind concrete arch bridge in Ft. Worth came to an end, and the bridge was opened to traffic in October. After the end of construction, we performed a series of static truck-load tests on the bridge to identify the live load response of the arches and establish their performance baseline. These results can

also be used for future maintenance of the bridge.

After 48 trips and 600 challenging hours in Ft. Worth, the field activities are completed in this research project. During the 20-month-long construction of the bridge, the stresses and prestress losses were successfully monitored, and a significant amount of valuable data was collected

for the elastic and time-dependent behavior of the arches. Future work will include further post-processing of the data and conducting parametric studies to evaluate the structural behavior of arches in a broader perspective.



A truck load test being performed on the arch bridge

ASR Affected Walls - Gloriana Arrieta, David Wald, Nick Dassow, Trey Dondrea, Alissa Neuhausen, Daniel Elizondo, Joseph Klein, Sara Watts & Beth Zetzman

The semester is shaping up to be a busy one for the ASR team! Specimen casting will resume soon and control tests are expected to start in early March. Meanwhile, specimens cast over the past year continue to develop ASR (alkali-silica reaction) while conditioning in our greenhouse facility. Recently, more atten-

tion has been devoted toward understanding retrofit techniques and their effectiveness. As such, our time has been dedicated to research in the literature to get a better grasp of shear and anchorage behavior and what retrofit options will yield the best results.

Inside the greenhouse



Ferguson Structural Engineering Lab Newsletter

Expanding Use of Elastomeric Bearing Pads to Higher Demand Applications - Kostas Belivanis, Liwei Han & Daniel Sun

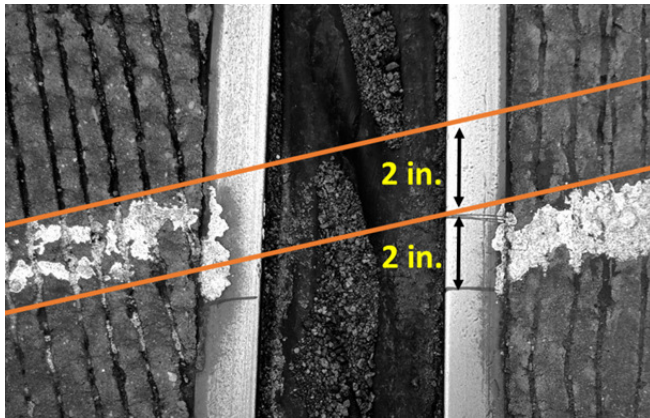

Offset due to permanent slip is observable at the expansion joint of this bridge

The use of elastomeric bearings in steel bridge applications provides an economic and reliable means of accommodating the superstructure movement. In addition,

systems are easier to fabricate, erect, and maintain, and the long-term bridge behavior is improved.

Results from this research study will provide valuable insight into the behavior of large elastomeric bearing pads for use in high demand applications. As design procedures in AASHTO were developed based numerical and experimental research on smaller bearings, there are concerns regarding the applicability of those procedures for large bearings. The main goal of this study is to

verify those design procedures and develop suggestions for corrections where needed.

At this phase of the study, a bridge has been instrumented (electronically and mechanically), tests are being run on different sized bearings, material directly from the specimens is being tested, and FEA studies are being conducted to correlate the results from the tests to develop reliable models for the subsequent parametric study.

Progressive Collapse Capacity of Composite Floor Systems - Michalis Hadjiioannou, Georgios Moutsanidis & Umit Can Oksuz

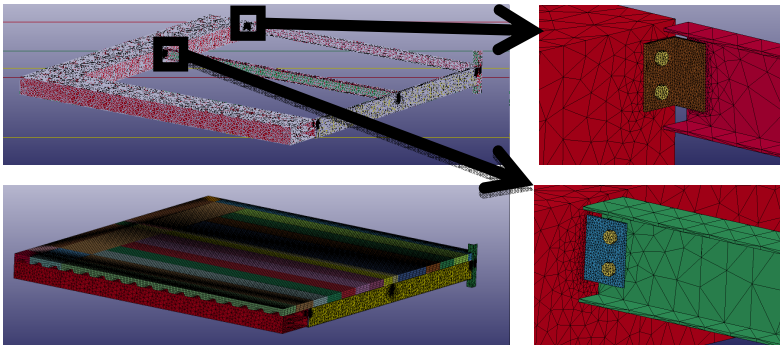

High fidelity FE model of the first test specimen

Two large-scale experimental tests on composite floor systems have been conducted. Both specimens were loaded to collapse under a middle column removal scenario. Both tests verified the significant contribution of floor slabs in progressive collapse scenarios. Detailed finite element models have

also been developed and are currently being validated with the experimental data obtained from the tests. The models are able to explicitly capture failure modes that have been observed during the tests such as connection fracture, bolt fracture, and concrete cracking.

Good agreement has been found thus far, though the models are still being refined. Significant effort has also been given to developing modeling techniques using commercially-available structural design software that can be used to predict the capacity of composite floor systems under a column loss.

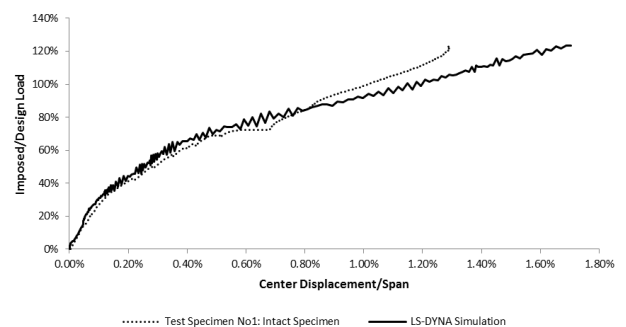

Comparison of measured and predicted response of interior column removal specimen

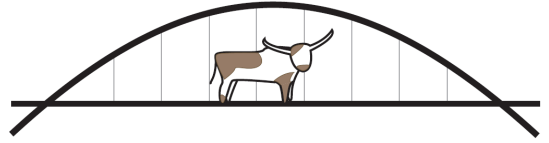

BUILDING 24 COMMITTEE

*Committee Vision: Increase **productivity** at Ferguson Laboratory through improved **communication** and **collaboration** of students, staff, and faculty*

JNT Golf Tournament - May 14

BASTROP, TX Have you started looking at possible summer plans once finals are over? Well, wait to leave until after May 14th so you can participate in the annual structural engineering department golf tournament. The 21st Annual J. Neils Thompson Golf Tournament will be held at the Pine Forest Golf Course in Bastrop on the Wednesday immediately following finals, May 14th. The tournament celebrates the end of the semester and honors J. Neils Thompson, who was the lead developer of UT's civil engineering research program, as well as a scratch golfer.

The format and rules of this tournament create a fun atmosphere for all skill levels (more than 25% of the participants have never played golf before). Around eighty students, professors, staff, and industry representatives have participated in past tournaments. The tourna-

ment format is a "shotgun start, four-person best ball scramble." With such a scramble, all four players hit from the same spot and use the best shot of the group for their next shot (i.e. three players pick up their ball and shoot from the "best ball"). Thus, anyone has the chance to make a difference.

The tournament is a lot of fun and more details will be released closer to the tournament. Not only do you get to spend time with your fellow classmates, the tournament offers an opportunity to network with professionals who sponsor the outing to help reduce the cost for students. All skill levels are encouraged to participate and we make sure to add some "special rules" to make the round of 18 enjoyable for everyone. More details will follow during the semester.

Special points of interest:

- SEMM RECRUITMENT, FEBRUARY 28
- ANNUAL PICNIC AND SOFTBALL GAME, MAY TBD
- JNT GOLF TOURNAMENT, MAY 14

2013 Winning Team
 Mike Larson
 Janet Larson
 Nancy Larson Varney
 Jason Varney



Everyone has a chance to sink the winning putt!

Information about the Newsletter

The goal of this publication is to keep those working at FSEL aware of the status of ongoing projects around them. In addition to projects, we may also highlight special events, people, or news of interest. The newsletters will come out once a semester, three times a year.

In this first issue of 2014, sixteen research projects at FSEL are summarized. Hopefully you will learn something new about each project so as to initiate more discussions with your fellow researchers.

Feedback
 Kerry Kreitman
 E-mail: kerry.kreitman@utexas.edu