



TEXAS
The University of Texas at Austin

FERGUSON
STRUCTURAL ENGINEERING
LABORATORY



FSEL
NEWSLETTER

Volume 12, Issue 2, November 2021

FSEL

The Ferguson Structural Engineering Laboratory (FSEL) located on the Pickle Research Campus of The University of Texas at Austin is named after Professor Phil M. Ferguson, who was an inspirational teacher and a meticulous researcher.

We hope that you enjoy learning about our laboratory and ongoing research.

NEWS FROM BUILDING 24

CONGRATULATIONS ARE IN ORDER!

Many of our fellow students have made big moves recently. We want to congratulate them all for their accomplishments and wish them the very best!

- **JAY MALVIYA** graduated with his M.S. last Summer, and is now working for Holmes in San Francisco, CA.
- **MATT REICHENBACH**, who had been working as a Post-Doc researcher and teaching at UT for the past year, has taken a teaching position at Drexel University in Philadelphia, PA.
- **SUNGHYUN PARK** graduated with his Ph.D. last Spring and is now working as a Post-Doctoral researcher at FSEL.
- **JARROD ZABORAC** graduated with his Ph.D. last Spring and is now working as a Post-Doctoral researcher within the CBEI group.
- **GEORGE GE** graduated with his Ph.D. in the Spring semester and is working for RHC Engineering in Seattle, WA.
- **CHEN LIANG** finalized his 2-year research stay at UT at the end of the Summer and went back to Tonji University in China, where he will finish his Ph.D. studies.v

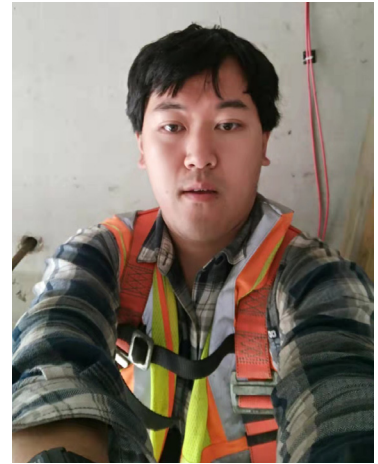

Dr. Xiaomeng(George) Ge



Dr. Jarrod Zaborac



Dr. Sunghyun Park



Chen Liang

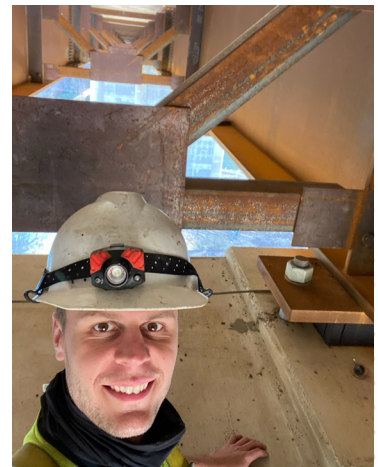

Dr. Matt Reichenbach

ONGOING RESEARCH AT FSEL

There are 34 student researchers working at FSEL, and this newsletter summarizes our ongoing work. We hope you enjoy learning more about the exciting projects we have going on at FSEL.

LEAK-DETECTION IN WATER DISTRIBUTION NETWORKS THROUGH LOW-COST DISTRIBUTED ACOUSTIC SENSORS

PROJECT TEAM: KONSTANTINOS SITAROPOULOS

SUPERVISORS: SALVATORE SALAMONE & LINA SELA

Leak detection and assessment of pipes in water distribution systems spanning huge geographical distances is complex, since the majority of the pipes are buried underground and are not readily available for visual or physical inspection. Conventionally, leak detection relies on periodic inspections, which are time-consuming and depend heavily on the skills of the inspectors. The overarching goal of this research is to develop new computational techniques for leak detection in water systems through transforming raw sensing data into actionable information for detecting leaks-before-breaks and, in turn, reducing the associated costs, service disruptions, as well as water and energy losses. The research team will utilize a fixed sensor network

of permanently installed hydrophones and advanced signal processing techniques that continuously processes the raw data. The main objective is to characterize and benchmark the acoustic signature of leaks in water distribution systems (e.g., identify dominant frequencies and spectral densities), and test the sensitivity of acoustic signatures to leak size and location, hydraulic conditions (e.g., background pressure and flow), as well as pipe parameters (e.g., size and material). On top of that, advanced data processing algorithms will be employed to automatically identify and locate leaks by analyzing the acoustic waves recorded by the hydrophones.

Field setup



Leak-free case

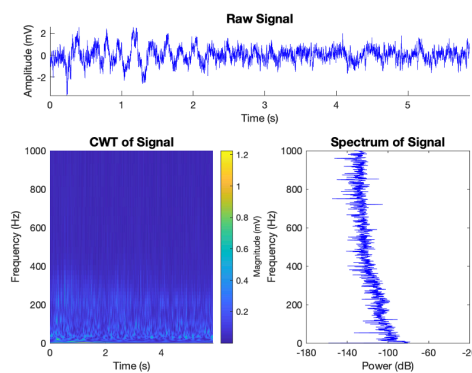

Leak case

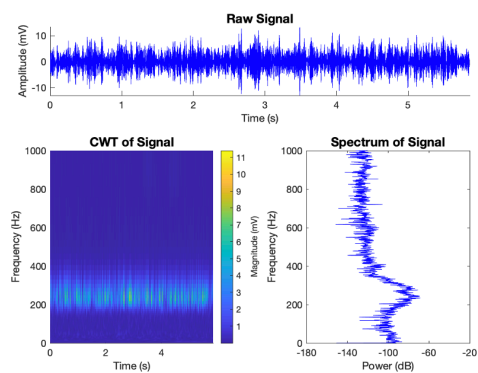

Field test setup (left) and plots [raw signal, wavelet transform and power-spectrum] for a typical leak-free (middle) and leak (right) signal recorded through the hydrophones.

DEVELOPMENT OF KNOWLEDGE IN THE APPLICATION OF STRUT-AND-TIE MODELING

PROJECT TEAM: ANAS DAOU, DENNIS WANG, YIBIN SHAO, AYAH ALOMARI & ZACH WEBB

SUPERVISOR: OGUZHAN BAYRAK

For the study of the curved-bar-node, the researchers are investigating the effect of the bend radius on the strut-and-tie model (STM) and the shear strength of beam-column joints. The first specimen construction is completed, and testing is in process. The mechanics of load transfer by using high-fidelity instrumentation is currently being studied. Accompanying FEM models for the test specimens shall inform the study of the mechanics of load transfer. Ultimately, with a better understanding of the load transfer mechanism, as aided by full-scale tests and realistic analyses, the research team will develop design recommendations consistent with the



Deep beam testing setup

existing STM provisions of AASHTO LRFD Bridge Design Specifications.

For the confined nodal region study, the research team aims to study and analyze the beneficial effect of confinement on nodal regions in the STM through an experimental program and analytical methods. Currently, the project has accomplished the preliminary theoretical analysis and built the first specimen. Next, the new specimen will be designed and tested for the CCT node. Furthermore, experimental results will modify the finite element model to produce a more accurate modification factor for a more efficient future STM design.



Curved-bar-node Steel rebar cage

DEVELOP NEXTGEN TEXAS BRIDGE DECK

PROJECT TEAM: DYLAN GENTRY, DENNIS WANG, & ZACH WEBB

SUPERVISOR: OGUZHAN BAYRAK

This project aims to develop design guidelines for a full-width partial-depth precast concrete panel (PCP) bridge deck. In other words, the research team wants to produce a design for partial-depth PCPs that can be used as permanent formwork over the full width of the bridge, including the overhangs.

The project is currently in the Load Testing task. Twenty-four specimens with varying geometry and loading conditions will be tested during this task. The specimens consist of 4" partial-depth PCPs connected by wire trusses. They will generally be tested in four-point bending to simulate the negative moments generated by a bridge overhang

under gravity loads. Over the last summer, the research team finished the design of the loading frame and erected it, and prepared the first specimen for testing. The first structural test has been recently conducted.

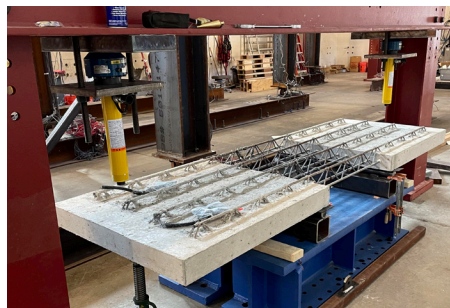

First specimen installed in four-point bending loading frame

IN THIS ISSUE

Leak-Detection In Water Distribution Networks Through Low-Cost Distributed Acoustic Sensors

Development Of Knowledge In The Application Of Strut-And-Tie Modeling

Develop Nextgen Texas Bridge Deck

System Level Seismic Performance Of Steel Gravity Framing

Evaluate Performance Of Closure Joints For Side-By-Side Accelerated Bridge Construction (Abc) Superstructure Systems

Strut-And-Tie Modeling And Design Of Drilled Shaft Footings

Development Of Non-Fracture Critical Steel Box Straddle Caps

Seismic Performance Of Moment-Resisting Frames With Fuse-Type Connections

Proof-Of-Concept: Deployable & Adaptable Structural System For Seismic Hazard Mitigation

Evaluate The Deployment Of High Strength Reinforcing Steel In Texas

Develop And Validate Precast Column Solutions For Texas Bridges

Refined Design Methods For Lean-On Bracing

Utilizing Steel Fibers As Concrete Reinforcement In Bridge Decks

Shear Behavior Of Spliced Post-Tensioned Girders With UngROUTED Tendons

Evaluation Of Seamless Bridges

Use Of Larger Diameter Shear Studs For Composite Steel Bridges

Analyze Shear Capacity Of Texas Standard Prestressed Beams From Strut-And-Tie Models Of Beam Ends

Develop Deck And Overhang Design Guidelines For Sound Walls And Other Heavy Loads

Develop Guidance For Structural Behavior Of Tall Haunches In Txdot Beam And Girder Bridges

Proposed Modifications to AASHTO Cross-Frame Analysis and Design (WT Extension)

SYSTEM LEVEL SEISMIC PERFORMANCE OF STEEL GRAVITY FRAMING

STUDENT RESEARCHER SANGWOOK PARK

EXTERNAL ADVISORS: LAWRENCE KRUTH, PATRICK MCMANUS, THOMAS SPUTO, & JUDY LIU

SUPERVISORS: ERIC WILLIAMSON, TODD HELWIG, MICHAEL ENGELHARDT, & PATRICIA CLAYTON

This research study investigates the seismic performance of steel gravity framing with composite floor slabs, considering system-level behavior. To better understand the system-level behaviors, large-scale tests on a multi-bay structure will be conducted to estimate the contribution of the gravity framing to a building's seismic resistance. Two specimens of two-half stories and two-by-three bays of steel gravity framing with composite floor slabs will be fabricated at the Ferguson Structural Engineering Laboratory and subjected to quasi-static, displacement-controlled cyclic loading with hydraulic actuators.

The direction of the metal decking will be considered as one of the major design variables: for one specimen, the metal decking will be oriented parallel to the girders while for the second specimen, it will be oriented perpendicular to the girders. Strain gauges, linear potentiometers, and motion-tracking systems will be installed to investigate

the flow of forces through the structural system. Such data permits estimation of the flexural resistance of the composite connections when system-level effects and multi-bay interactions are considered.



Two-by-three bays of steel gravity framing

EVALUATE PERFORMANCE OF CLOSURE JOINTS FOR SIDE-BY-SIDE ACCELERATED BRIDGE CONSTRUCTION (ABC) SUPERSTRUCTURE SYSTEMS

PROJECT TEAM: NIYAM SHAH & ZACH WEBB

SUPERVISORS: OGUZHAN BAYRAK & KEVIN FOLLIARD

The main problem engineers and contractors face today is devising a plan to fix deteriorating bridges while accommodating vehicles on the roadway. A method known as Accelerated Bridge Construction (ABC) was devised to combat the outmoded techniques of constructing/rehabilitating bridges. ABC accomplishes the goal of minimizing traffic disruptions and construction time by utilizing prefabricated bridge elements. To provide continuity between these elements, a connection known as a closure joint must be used. Closure joints are critical in ABC and help transfer shear and moment between deck panels. Closure joints can use normal-strength concrete, ultra-high performance concrete (UHPC), or an intermediate combination mix. These are coupled with different reinforcement details such as straight bars, hooked bars, etc. However, there has been concern regarding the long-term durability of closure joints due to their cast-in-place nature and material/reinforcement specifications.

The research team has recently completed the instrumentation of two new ABC TxDOT bridges in the Bryan and Amarillo Districts with strain gauges to monitor the performance of closure joints. In the next couple of months, the researchers hope to implement closure joint material specifications from Dr. Folliard's Materials Lab

to large-scale deck specimens which will be tested in both flexure and shear.

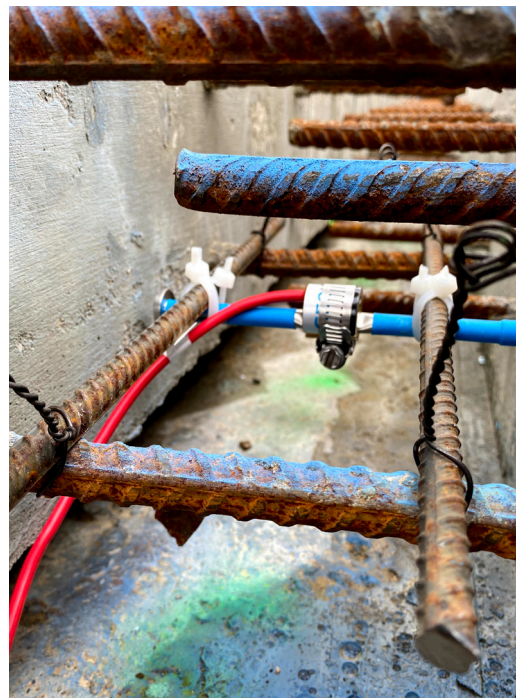

Strain gauge installation at Bryan OSR bridge

STRUT-AND-TIE MODELING AND DESIGN OF DRILLED SHAFT FOOTINGS

PROJECT TEAM: YOUSUN YI, DENNIS KIM, DENNIS WANG, & ZACH WEBB

SUPERVISOR: OGUZHAN BAYRAK

The design and detailing of reinforced concrete footings supported by a grid of drilled shafts (drilled shaft footings) varies greatly on a state, district, and even municipality basis due to the continued use of legacy; sectional design method. Therefore, a full transition to strut-and-tie modeling is required for the uniform design and detailing of

drilled shaft footings. Based on the comprehensive research work of this project, which includes large-scale testing and numerical studies, the research team has proposed the design guidelines for drilled shaft footings using the three dimensional strut-and-tie method with design examples. The project findings have indicated that the proposed recommendations improve the accuracy of the ultimate strength predictions for a database that includes drilled shaft footing tests from the literature and the current study without generating unconservative or overly conservative predictions.

However, the research did not cover the drilled shaft footings subjected to biaxial flexure loading scenarios, which are frequently considered loading cases in designing drilled shaft footings. Therefore, a follow-up research project was launched in October to cover the biaxial flexure loading cases. The outcomes of the project will be incorporated into the proposed guidelines.

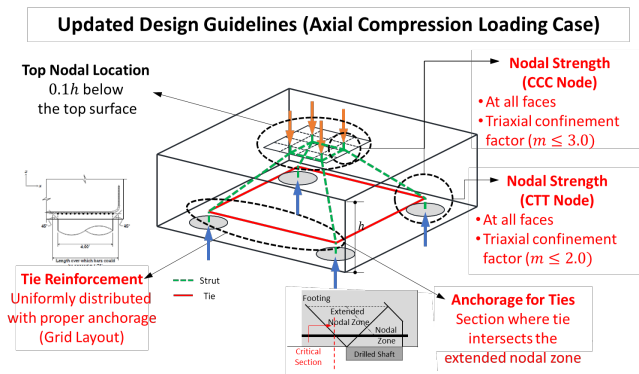

DEVELOPMENT OF NON-FRACTURE CRITICAL STEEL BOX STRADDLE CAPS

PROJECT TEAM: ESTEBAN ZECCHIN, EMMA WILLIAMS, SUNGHYUN PARK, CHEN LIANG, MATT REICHENBACH, & RYAN STEVENS

SUPERVISORS: TODD HELWIG, MICHAEL ENGELHARDT, ERIC WILLIAMSON, & MATT HEBDON

Fracture Critical classification (AASHTO LRFD, 9th Ed.) imposes more stringent design, fabrication, and inspection requirements to steel box straddle caps (SBSCs), resulting in increased long-term costs for the bridge owner. This research study aims to design internally redundant SBSCs that would therefore be classified as Non-Fracture Critical.

The experimental phase of the project includes the test of several full-scale specimens with different internal redundancy details such as post-tensioning bars to provide a secondary load path in the faulted state and bolting the bottom flange to the webs to separate the components in tension. During the Summer, the researchers fabricated and erected the full-scale test setup and configured the required equipment.

The test protocol includes 1) notching the edges of the bottom flange and the lower portion of the webs to determine the location of the cracks, 2) applying cyclic loading to grow sharp fatigue cracks from the notches, and 3) loading the specimen to fracture while it is kept at lower-shelf temperature (-200 °F) using liquid Nitrogen.

The research team expects to finalize the experimental testing of the full-scale specimens by the end of this year. After that, the focus will be put on numerical modeling and parametric studies.



Full-scale specimen installed for fracture test

SEISMIC PERFORMANCE OF MOMENT-RESISTING FRAMES WITH FUSE-TYPE CONNECTIONS

STUDENT RESEARCHER: JOSEPH GILROY

SUPERVISOR: PATRICIA CLAYTON & MICHAEL ENGELHARDT

Recently, there has been significant research into the development of “fuse-type connections” for steel special moment resisting frames (SMRF) for seismic applications. These fuse-type SMRFs move the plastic hinging from beams to the connecting elements, which are designed for ductile yielding. Therefore the beam is capacity designed for the connection. This inversion has important implications for system behavior, such as additional flexibility from partial strength connections, or the beams being unable to reach their plastic moments. This project aims to assess the seismic performance of these systems using the design provisions that are currently required per AISC and ASCE7 specifications.

The primary tool in this investigation is nonlinear response history analyses conducted in OpenSEES for a FEMA P695 style assessment. Extensive work has been done in deciding appropriate analysis and modeling choices for fuse-type SMRFs, as well as the automation of analysis for both design and assessment. Currently, the researchers are refining the nonlinear response history data for building archetypes designed per current code requirements,

designing new fuse-type SMRFs archetypes with alternate design requirements, and conducting nonlinear response history analyses on previously designed fuse-type SMRFs with different post-yield behaviors that represent potential future systems.

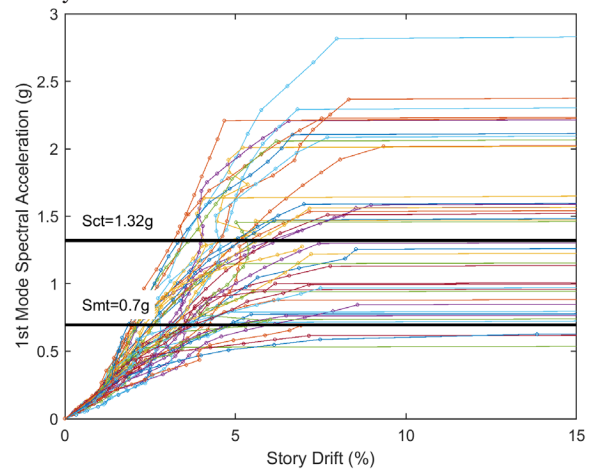

Preliminary response history analyses results. Median collapse spectral acceleration ($S_{c,v}$) is compared to MCE spectral acceleration ($S_{m,t}$) for a building.

PROOF-OF-CONCEPT: DEPLOYABLE & ADAPTABLE STRUCTURAL SYSTEM FOR SEISMIC HAZARD MITIGATION

PROJECT TEAM: ABHISHEK ARUNACHALAM AGORAMURTHY & SABIKA BHARMAL

SUPERVISOR: ERIC WILLIAMSON

Civil structures can experience vastly different demands during their service life, depending on the environmental and imposed loads. The research team proposes implementing a deployable and adaptable structural system for seismic hazard mitigation of building structures, considering recent advancements in control technologies. The proposed structure is compact and effective in resisting day-to-day loads when in the passive truss-moment frame configuration. When excited by an earthquake, the structure deploys itself to a vertical-link eccentrically braced frame configuration. A closed-chain robotic manipulator drives the above transformation and subsequently contributes to the active control of structural vibrations. The deployable and adaptable structural design also enables modular construction with easy-to-assemble construction joints. Further, using this structural system reduces the structure’s material consumption by utilizing nominal operational energy in buildings located in high seismic zones.

The research team plans to implement a small-scale prototype structure on a table-top shake table as a proof-of-concept. Subsequently, the team intends to conduct

parametric studies to test the system’s efficacy and determine the feasibility of using this approach for large-scale structures. If preliminary research shows that this structural system efficiently handles both gravity and seismic loads, the researchers foresee this technology possibly serving seismic retrofitting applications in existing structures.

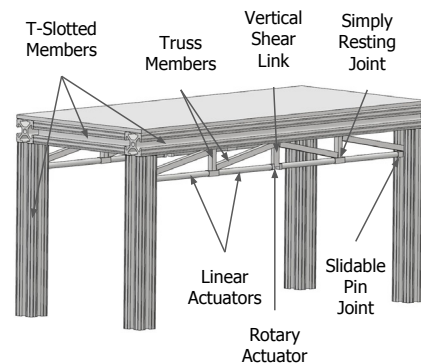

Illustration Caption: 3D model of the deployable and adaptable prototype structure

EVALUATE THE DEPLOYMENT OF HIGH STRENGTH REINFORCING STEEL IN TEXAS

PROJECT TEAM: YONGJAE YU, ZACH WEBB, & CHESKA ESPANOL

SUPERVISOR: OGUZHAN BAYRAK

Recent editions of the AASHTO LRFD Bridge Design Specifications have adopted code updates to implement high-strength reinforcing steels with yield strengths up to 100 ksi. The use of high-strength reinforcement has advantages of reduced steel congestion and additional extreme limit state or overload capacity. However, TxDOT has not adopted these higher-strength reinforcing steels in practice. The reasons include the potential need for enhanced TxDOT requirements beyond the specifications and an aversion to passively reinforced structural elements that result in higher reinforcement stress and resultant cracking that might be visually concerning.

This project aims to remove barriers that limit the implementation of high-strength reinforcing steel in Texas bridge designs. The project includes various experimental programs such as spliced beams, deep beams, deck slabs, footings, and prestressed girders. Currently, the research

team is preparing a beam splice test and deck slab test.

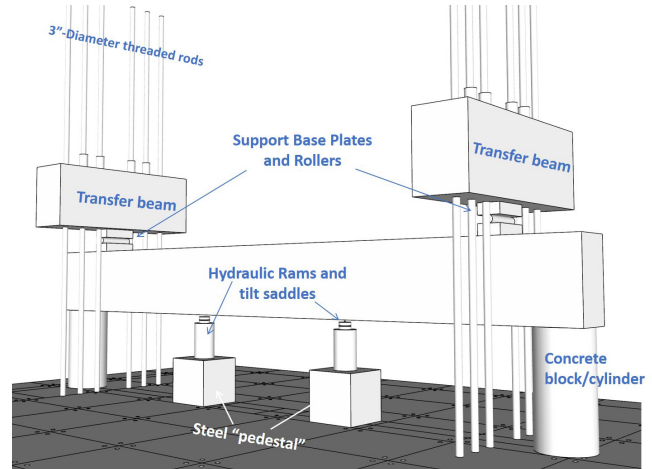

Scheme of test setup for beam splice test

DEVELOP AND VALIDATE PRECAST COLUMN SOLUTIONS FOR TEXAS BRIDGES

PROJECT TEAM: LUKE SMALL, LUCAS ZILVETI, ZACH WEBB, & DENNIS WANG

SUPERVISOR: OGHUZAN BAYRAK

Precast bridge elements can be used to accelerate construction, reducing road closures and traffic. TxDOT Project 0-7089 aims to investigate alternative precast column systems that can accomplish this and be more economical than CIP solutions.

The preliminary design of columns was recently completed. Two styles were chosen to be tested: precast solid columns and precast shell columns with a cast-in-place core. The latter of the two will have reinforcement in the shell, while the solid option will closely resemble a CIP solution. Two different types of connections to the foundation will be tested as well: grouted ducts and sockets. Meanwhile, the bent cap connections being investigated are grouted ducts and grouted pockets, both very similar to current TxDOT standards. This completion of the design task has allowed the project to develop a testing program and setup for large-scale testing of the different systems.

Concurrently, the team has also been preparing specimens to investigate the interface shear strength between two layers of concrete cast at different times. The specimens will compare cast-in-place concrete against precast concrete with a variety of surface roughness and shapes. This

research will compare axial force to vertical shear strength to better inform final column designs utilizing a concrete interface.

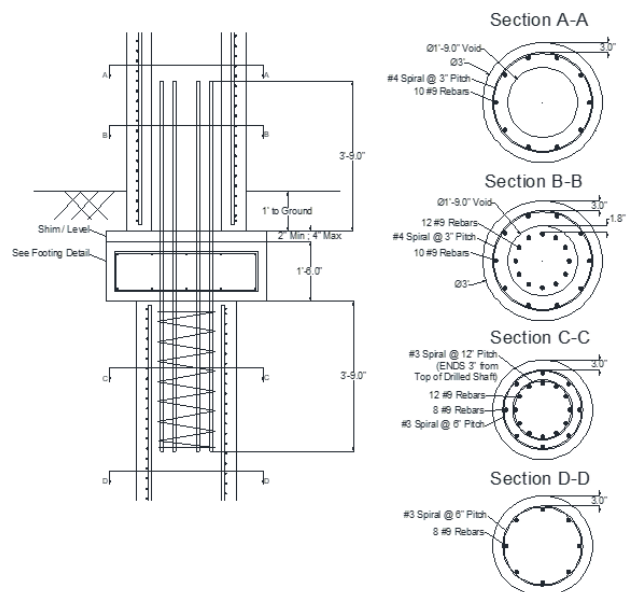

Preliminary design for a hollow precast shell socket connection to a same size or smaller diameter drilled shaft

REFINED DESIGN METHODS FOR LEAN-ON BRACING

PROJECT TEAM (UTAUSTIN): DAVID FISH, AIDAN BJELLAND, CHEN LIANG, & MATTHEW REICHENBACH

PROJECT TEAM (TEXAS A&M): CLAIRE GASSER

SUPERVISORS (UT AUSTIN): TODD HELWIG, ERIC WILLIAMSON, & MICHAEL ENGELHARDT

SUPERVISORS (TEXAS A&M): STEFAN HURLEBAUS & MATTHEW YARNOLD

Cross-frames and diaphragms are provided to improve the lateral-torsional buckling resistance of bridge girders during construction. These components require extensive handling, cutting, and welding during fabrication. The braced locations are also a source of fatigue concerns in the finished bridge. Lean-on bracing is an alternative bracing method that reduces the number of elements in the cross-frames by having several girders 'lean' on a single cross frame. Currently, guidance for these lean-on applications is limited. Therefore, the objective of the research project is to develop and refine design guidelines for lean-on bracing applications.

Over the summer, the research team was able to instrument a bridge with lean-on bracing located on SH 105 over the Brazos River. The bridge was instrumented to collect strain data from live-load testing for finite element model verification.

Data from this bridge, along with data from the US82 ML Underpass at 19th Street, were examined to inform the instrumentation of the team's next bridge: FM 1902B

Overpass at Chisholm Trail Parkway. The Chisholm Trail bridge will be instrumented to provide further verification cases for the upcoming parametric studies the research team will be conducting. Ultimately, these parametric studies will be used to highlight the effects of lean-on bracing configurations in a wide range of bridge types and aid in the development and refinement of design guidelines.



SH 105 Instrumentation

UTILIZING STEEL FIBERS AS CONCRETE REINFORCEMENT IN BRIDGE DECKS

PROJECT TEAM: SOON KWANG JEONG, JARROD ZABORAC, COLIN CHAPPELL, ZACH WEBB, & THANOS DRIMALAS

SUPERVISORS: OGUZHAN BAYRAK & DR. KEVIN FOLLIARD

EXTERNAL ADVISORS: JUAN MURCIA-DELISO & JONGKWON CHOI

Precast prestressed concrete panels (PCPs) as a stay-in-place formwork is the method widely used in Texas. PCPs support the weight of the cast-in-place (CIP) top half of the concrete and the loads from traffics.

Bridge decks often experience cracking during the service, making them susceptible to deterioration and commonly repaired elements. Steel fiber reinforced concrete (SFRC) can improve concrete cracking behavior.

This project aims to develop an improved SFRC mix design and optimized reinforcement details. Deck strip tests evaluate crack control and load-resisting performance under idealized flexural loading conditions. Nonlinear finite element analysis in conjunction with deck strip tests will give agreeable design specifications for full-scale testing. Full-scale tests with four different optimized reinforcements will be tested to examine the system-level performance of SFRC bridge decks. During the Fall of 2021, the experimenting

testing for the cracking behavior of top mat concrete for the longitudinal and transverse directions will be performed.

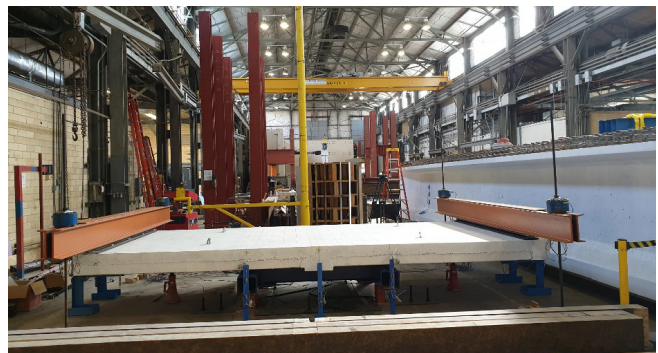

PCP test setup

SHEAR BEHAVIOR OF SPLICED POST-TENSIONED GIRDERS WITH UNGROUTED TENDONS

PROJECT TEAM: SANGYOUNG HAN, JONGKWON CHOI, & ZACH WEBB

SUPERVISOR: OGUZHAN BAYRAK

This project funded by TxDOT aims to evaluate the large-scale testing specimen of spliced girder technology with various profiles of post-tensioning with grouted and ungrouted tendons. During this Fall semester, the UT research team completed the planned test program, including six testing specimens involving 12 structural shear tests. Given the large-scaled specimen subjected to tremendous shear force, the final failure mode exhibited sudden web-crushing involved the busting failure with dynamiting sound.

Now, the research team will move to the next step to analyze the collected data and will provide the updated shear strength design for spliced girder technology as the proposed revisions to the most recent editions of the TxDOT LRFD Bridge Design Manual and AASHTO.



Large-scale test specimen

EVALUATION OF SEAMLESS BRIDGES

PROJECT TEAM: XIAOYI CHEN & JAY HEMENDRA MALVIYA

SUPERVISORS: TODD HELWIG & JORGE ZORNBERG

EXTERNAL ADVISORS: JUAN MURCIA-DEL SO

The seamless continuously reinforced concrete pavement (CRCP) bridge system eliminates the expansion joints over the bridge abutment and at the end of the approach slab, which can reduce maintenance costs, minimize the bumps and noises, and improve durability. A transition zone between CRCP and bridge will be designed to accommodate the additional effects due to the seamless connection.

A comprehensive two-phase experimental program has been proposed to characterize the concrete slab-base interaction, which governs the longitudinal load transfer mechanism in the transition zone. The research team is currently performing Phase II testing, for which two self-reacting test frames have been designed and fabricated to conduct full-scale push-off tests. The specimens include cast-in-place concrete on top of cement stabilized bases with one or two layers of polyethylene sheets in between as bond breakers. The loading protocol consists of eight cycles of full-reversed horizontal displacements under three normal stress levels.

The research team will continue tests with other potential bond breakers in an attempt to increase the friction.

Numerical analysis was also performed using Abaqus and SAP2000 to model the system behavior.

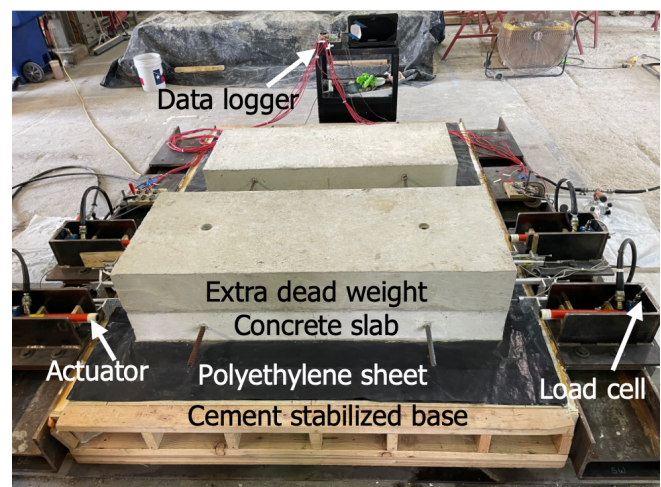

Push-off test setup

USE OF LARGER DIAMETER SHEAR STUDS FOR COMPOSITE STEEL BRIDGES

PROJECT TEAM: XIANJUE DENG, LU WAN, & YUCEL ALP

SUPERVISORS: MICHAEL ENGELHARDT, TODD HELWIG, & ERIC WILLIAMSON

This project studies the feasibility of using 1-1/8" diameter shear studs in composite steel bridge. Researchers are currently working on component level test of large diameter stud specimens, which is also called push-out test. The push-out specimen consists of a steel beam, a concrete deck, and shear studs. The shear studs provide the connection between steel beam and the concrete deck. Push-out specimen is

small comparing to actual bridge segments but it can reflect the lower-bound of the shear stud performance. The test setup for push-out test is a self-reaction frame, which means load created during the test will all be sustained by itself. A total of 15 push-out tests, both static and dynamic, will be performed to study the large stud performance under various conditions.



Push-out test specimen

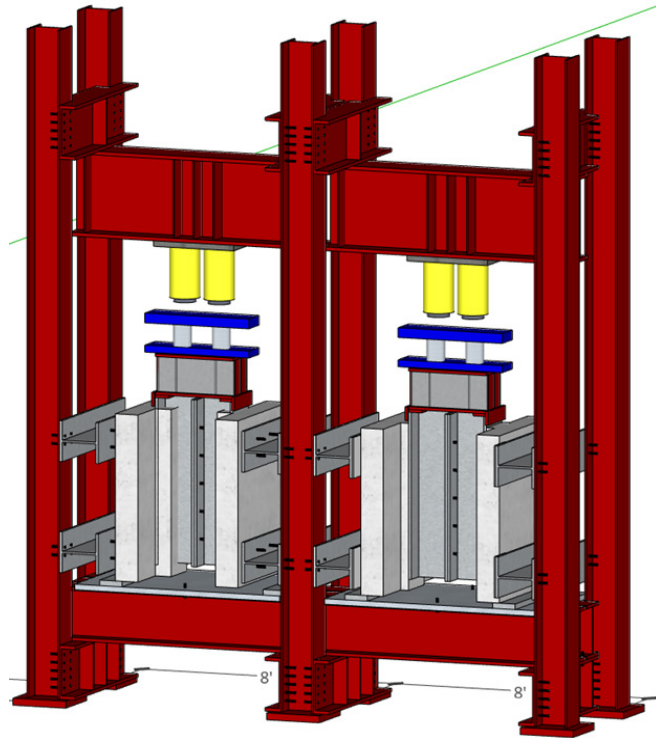

Self-reacting test setup

ANALYZE SHEAR CAPACITY OF TEXAS STANDARD PRESTRESSED BEAMS FROM STRUT-AND-TIE MODELS OF BEAM ENDS

PROJECT TEAM: HANSOL JANG & ZACH WEBB

SUPERVISOR: OGUZHAN BAYRAK

The purpose of this project is to verify that the end region shear stress of Texas standard prestressed beam can exceed the $0.18 f_c$ stress limit using STM. U-beam is one of the types in Texas standard prestressed beam, which contains unique features compared to other types of beams. U-beams have an inclined web, and stress flow can be affected by its characteristic geometry. The inclined web affects the force applied to the strut-to-node interface when using the STM. Furthermore, the stress flow in the end block can be expressed using two different shapes of cross-section STM when one bearing plate is used at the support of the U-beam. Therefore, the strut force should be calculated considering

the inclined web, and the difference between strut force and tie force will be compared when different shapes of STM are used in the end block with one bearing plate.

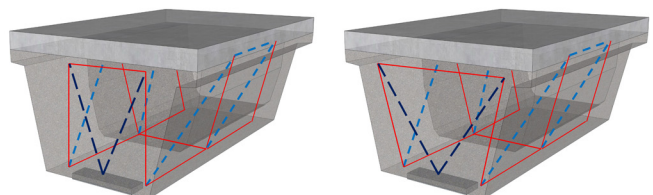

Different STMs for U-beam

DEVELOP DECK AND OVERHANG DESIGN GUIDELINES FOR SOUND WALLS AND OTHER HEAVY LOADS

PROJECT TEAM: BHUSHAN RAJ SELVARAJ & TANAKORN NGAMJARUNGJIT

SUPERVISORS: ERIC WILLIAMSON, TODD HELWIG, & MICHAEL ENGELHARDT

Economic considerations typically encourage limiting the total number of girders across the width of most bridges. The portion of a bridge deck extending past the fascia girders is known as the overhang. The width of overhangs is normally proportioned so that the same girder sections can be used for both the interior and fascia girders. While many state transportation agencies have guidelines on sizing and detailing bridge overhangs, current provisions are generally based on rules-of-thumb developed through past experience. Current provisions, however, are not sufficient for designing bridge deck systems that include large edge loads. Thus, heavy railings such as TxDOT's T80TT, which is taller and heavier than typical railings, cannot be used in many bridge applications where they may be desirable. The purpose of this project is to evaluate current design practices and procedures, using parametric finite element analyses, so that design guidelines can be developed to proportion

bridge deck systems with heavy railings having a high crash rating. The research team is currently conducting a literature review to identify the best design practices, past research, and methods of analysis for deck overhangs with railings.

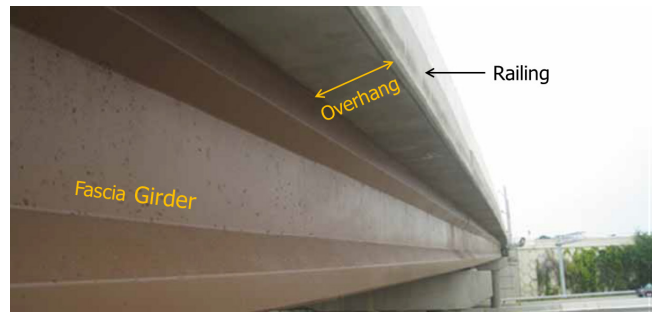

Bridge Deck Overhang and Railing

DEVELOP GUIDANCE FOR STRUCTURAL BEHAVIOR OF TALL HAUNCHES IN TXDOT BEAM AND GIRDER BRIDGES

RESEARCH TEAM: NIDHI KHARE & ZHENGHAO ZHANG

SUPERVISORS: ERIC WILLIAMSON, TODD HELWIG & OGUZHAN BAYRAK

This research project focuses on the behavior of both steel and prestressed concrete girder bridges with haunches that exceed allowable height limits. The haunch is a cast-in-place structural component between the top of a steel or prestressed concrete girder and the bottom of the deck. A primary function of haunches is to maintain a uniform deck thickness, accounting for camber and cross-slope. AASHTO and TxDOT provide design guidelines in which haunches are not permitted to exceed a specified height. Due to design errors, construction errors, or unusual geometry demands, actual haunch sizes could exceed the limits specified in current design specifications. To understand the behavior and limit states of girders with tall haunches, the research team is conducting full-scale push-out tests considering a wide range of design parameters. The push-out tests are performed using a self-reacting frame (shown in the accompanying figure). The ultimate shear capacity and the load-slip relationship are the most important test data reflecting the behavior of tall haunches. Additionally, detailed computational models will be developed for conducting a parametric study to understand limit states and ultimate capacities for the range of haunch dimensions encountered by TxDOT. Results from the testing program and parametric finite element analyses will be used to develop design and detailing guidelines for girders with tall haunches.

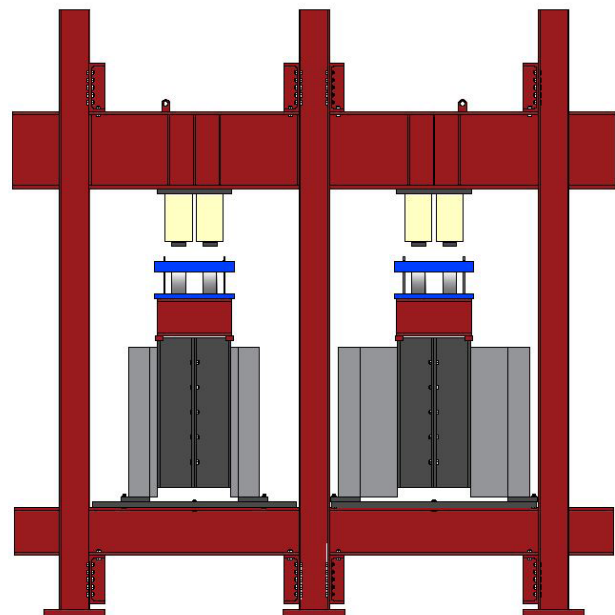

Self-reacting test setup

PROPOSED MODIFICATIONS TO AASHTO CROSS-FRAME ANALYSIS AND DESIGN (WT EXTENSION)

PROJECT TEAM: SUNGHYUN PARK & MATT REICHENBACH

SUPERVISORS: TODD HELWIG, & MICHAEL ENGELHARDT

Cross-frame systems consist of not only the cross-frame member itself, but also often connection and gusset plates. The cross-frame member is often fastened about only one leg (for angles) or only the flange or stem (for WTs). The nature of this connection introduces eccentricities about one or more axes, which inherently impacts the relative stiffness of the cross-frame.

One of the major objects of the original NCHRP Project 12-113 study was “Additional guidance on how to handle the influence of end connections on cross-frame member stiffness in refined analysis models.” The scope of the original study focused exclusively on single-angle sections as cross-frame members. Structural tee sections (referred to as WTs herein), however, are also commonly used by states such as Florida. As such, the intent of this extension study is to revisit the object by investigating cross-frames comprised of WT sections.

This extended WT study includes 1. Laboratory experiments, 2. Validation of FEA models, and 3. Parametric FEA studies. The research team has completed the tasks 1 and 2, and currently working on the extensive parametric FEA studies.

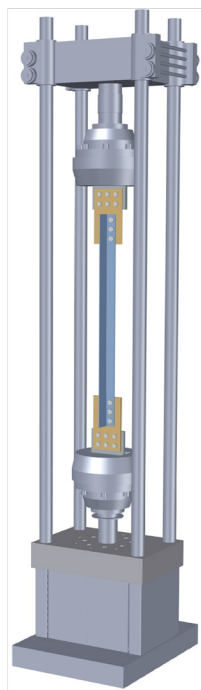

Experimental Test Setup

NEW FACES AT FSEL

ABHISHEK ARUNACHALAM

I am currently pursuing my second year of M.S. in Structural Engineering with a portfolio certification in Robotics. I am working on a research project in deployable and adaptable structures. I received my B. Tech. in Civil Engineering from IIT Delhi. I also did a semester-long internship at Thornton Tomasetti, Mumbai, and a summer research internship at UCSD. I have worked in the industry for around three years in technical and managerial roles. I am a tech-savvy person and I like to implement new things in monotonous workflows. My hobbies are singing, playing table tennis, chess, badminton, and tennis.



BHUSHAN RAJ SELVARAJ

I was born in the state of Tamilnadu, India, which is like Texas in many ways. I received my bachelor's degree in Civil Engineering from Anna University in my hometown Chennai and master's degree from the Indian Institute of Technology Kanpur. I worked in Mumbai for Larsen & Toubro as a Structural Engineer for 5 years in transportation projects designing bridges. My love for bridges made me pursue PhD at UT Austin. I am currently working on developing design guidelines for bridge deck overhangs with heavy railings and sound walls. Apart from structures, I enjoy learning about stars, being in nature, and playing table tennis and badminton.



PAUL TACKETT

I joined UT as a PhD Student in the Fall of 2021. I grew up in rural Kansas and attended the University of Kansas, and then Kansas State for BSc and MSc degrees. I've spent the last 8 years working as a bridge engineer. I'm passionate about the role infrastructure plays for the betterment of society. Outside of engineering, I'm a pretty avid outdoorsman, and my wife and I enjoy backpacking national parks and traveling when I am not droning on about bridges.



SEDA MURSEL

I am a first-year Ph.D. student at UT. I am from Istanbul, Turkey. After completing my BS degree in civil engineering at Bogazici University, I came to UT to pursue a master's degree. During my master's, I worked as a graduate research assistant under the supervision of Dr. Murcia and focused on the topic of seismic analysis of retrofitted buildings. Now, I am excited to begin my Ph.D. studies under the supervision of Dr. Bayrak and Dr. Ferche on research focused on the behavior of bent to column joints. In my free time, I enjoy swimming.

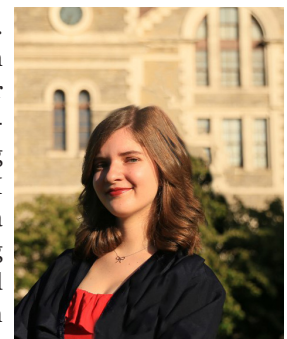

SABIKA BHARMAL

I am a civil engineering student on track to graduate in December 2021. I find the field of Civil Engineering interesting because of its unique combination of math, science, art, and design. In the past, I have participated in research on the UT campus by working on the Green Fund and LivingBIM projects. In addition to research, I have also had two internships and I am an ASCE officer again this year.



NEW FACES AT FSEL

BIG CHANGES IN THE FSEL STAFF

This semester brought many changes within the FSEL Staff:

First, we must say farewell to Abdullah and Angela, who had joined FSEL at the beginning of 2020. Abdullah went back to the University of California San Diego, where he took a position as Research Operations Manager. Angela took a new position as Administrative Manager for the CSEE group in the PGE Department. They were instrumental in keeping the Lab running smoothly, and we will miss them a lot. We wish you both much success in your new jobs!

Secondly, we want to welcome three new staff members: Hunter Cohen, Omar Gonzalez, and Ryan Stevens. If you haven't had the chance to meet them yet, here's a bit to know about them:

Hunter Cohen joined FSEL in September 2020 as technical staff to assist with the Concrete Bridge Engineering Institute and other concrete research projects. Previously, he was employed by The University's Facilities Services doing HVAC and building maintenance. This followed a long career of cooking in a variety of restaurants and earning a BS in Restaurant and Hotel Management from Texas Tech University. A lifelong Texan, he has lived in Austin since 2007 with his wife and daughter.



(Editor's Note: Hunter has been at FSEL for over a year already but, unfortunately, I screwed up and missed him in the corresponding edition; sorry, Hunter!)

Ryan Stevens joined FSEL from Virginia Tech, where he was a research engineer at the Thomas Murray Structural Engineering Lab. Ryan earned his BS and MS in civil engineering, both from Virginia Tech, with a structural engineering focus. While as a student and researcher, he tested sheet piles and steel moment connections, some with 60" deep beams and columns. He also has experience configuring closed-loop hydraulics and data acquisition systems. He joined us in August as a research engineer but has also taken on lab management responsibilities.



Omar Gonzalez joins FSEL after 13 years working with Grupo CTT -business partners of the MTS Systems brand in Mexico- as Senior Field Service Engineer. He earned his BS in Mechanical Engineering from Aguascalientes Institute of Technology. His experience covers routine maintenance, troubleshooting, and installation in mechanical, electrical, and electronic systems. He also has experience in calibration ISO and ASTM procedures. Omar joined in August 2021 as a Research Engineer to provide technical support to personnel in FSEL supporting in the maintenance of systems, design, fabrication and construction of structural engineering experimental setups and test specimens, and the execution of experiments.

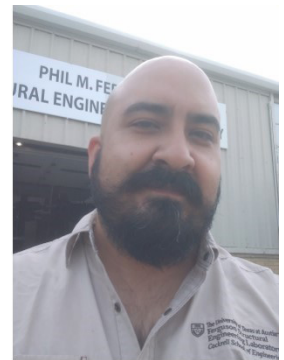

CONTACT US

Esteban Zecchin
Newsletter Editor
ezecchin@utexas.edu

**Ferguson Structural Engineering
Laboratory**
(512) 471-3062
fsel-main@austin.utexas.edu